

**LOGOSCREEN**  *nt*  
Paperless Recorder  
with TFT display  
and  
CompactFlash card

B 70.6580.2.0  
Interface Description

07.07/00472204



<b>1</b>	<b>Introduction</b>	<b>5</b>
<b>1.1</b>	<b>Preface</b> .....	<b>5</b>
<b>1.2</b>	<b>Typographical conventions</b> .....	<b>6</b>
1.2.1	Warning signs .....	6
1.2.2	Note signs .....	6
1.2.3	Representation modes .....	6
<b>2</b>	<b>General</b>	<b>7</b>
<b>2.1</b>	<b>Areas of application</b> .....	<b>7</b>
<b>2.2</b>	<b>System requirements</b> .....	<b>7</b>
<b>2.3</b>	<b>Identifying the interface</b> .....	<b>7</b>
<b>3</b>	<b>Connecting the interface</b>	<b>9</b>
<b>3.1</b>	<b>Position of the connection</b> .....	<b>9</b>
<b>3.2</b>	<b>RS232</b> .....	<b>11</b>
<b>3.3</b>	<b>Switching between RS232 and RS485</b> .....	<b>11</b>
<b>3.4</b>	<b>Configuration of the serial interfaces</b> .....	<b>12</b>
<b>3.5</b>	<b>Configuration of the Ethernet interface</b> .....	<b>13</b>
3.5.1	Parameters .....	13

---

# Contents

---

<b>4</b>	<b>Modbus protocol description</b>	<b>15</b>
4.1	Master-slave principle .....	15
4.2	Transmission mode (RTU) .....	15
4.3	Timing sequence for communication .....	16
4.4	Structure of a Modbus telegram .....	17
4.5	Device address .....	18
4.6	Function codes .....	18
4.6.1	Read n bits .....	19
4.6.2	Read n words .....	19
4.6.3	Write one bit .....	20
4.6.4	Write one word .....	21
4.6.5	Write n words .....	21
4.7	Transmission format (integer, float, double and text values) .....	22
4.8	Checksum (CRC16) .....	24
4.9	Error messages .....	25
4.9.1	Modbus error codes .....	25
4.9.2	Error messages for invalid values .....	26
4.9.3	JUMO error codes as integer return values .....	27
<b>5</b>	<b>Serial protocol types</b>	<b>33</b>
5.1	Modbus slave .....	33
5.2	Modbus master .....	35
5.3	Bar code .....	37
<b>6</b>	<b>Ethernet protocols</b>	<b>38</b>
6.1	HTTP .....	38
6.2	Browser connection .....	38
6.3	Modbus-TCP .....	39
6.4	E-mail (SMTP and POP3) .....	40
<b>7</b>	<b>Address tables</b>	<b>43</b>
7.1	Modbus addresses for important device and process data .....	43
<b>8</b>	<b>Index</b>	<b>53</b>

---

## 1.1 Preface

Please read this interface description before commissioning the interfaces for the instrument. Keep the interface description in a place which is accessible to all users at all times.

Please assist us to improve this interface description, where necessary.

Your comments will be appreciated.

Phone +49 661 6003-0

Fax +49 661 6003-607



All the necessary information for operating the interface is contained in this interface description. However, if any difficulties should still arise during start-up, please do not carry out any unauthorized manipulations. You could endanger your rights under the instrument warranty!

Please contact the nearest subsidiary or the head office in such a case.



When returning modules, assemblies or components, the regulations of EN 100 015 “Protection of electrostatically sensitive components” must be observed. Use only the appropriate **ESD** packaging for transport.

Please note that we cannot accept any liability for damage caused by ESD.

**ESD** = electrostatic discharge

---

# 1 Introduction

---

## 1.2 Typographical conventions

### 1.2.1 Warning signs

The symbols for **Danger** and **Caution** are used in these operating instructions under the following conditions:



**Danger**

This symbol is used when there may be **danger to personnel** if the instructions are ignored or not followed correctly!



**Caution**

This symbol is used when there may be **damage to equipment or data** if the instructions are ignored or not followed correctly.



**Caution**

This symbol is used where special care is required when handling components liable to damage through electrostatic discharge.

---

### 1.2.2 Note signs



**Note**

This symbol is used when your **special attention** is drawn to a remark.

abc<sup>1</sup>

**Footnote**

Footnotes are remarks that refer to specific points in the text. Footnotes consist of two parts:

A marker in the text, and the footnote text.

The markers in the text are arranged as continuous superscript numbers.

---

### 1.2.3 Representation modes

0x0010

**Hexadecimal number**

A hexadecimal number is identified by being preceded by an "0x" (here: 16 decimal).

---

### 2.1 Areas of application

The paperless recorder has several interfaces:

- as standard: a TTL setup connector on the front panel, and on the back (only for a Modbus slave)
  - as standard: serial interface RS232 or RS485 (Modbus slave, Modbus master, bar code)  
for communication with the bus system or a PC. This can be used to read out measurements or other device and process data from the paperless recorder.
  - as standard: Ethernet 10/100 Mbit/sec  
for communication with the instrument via a network (setup, browser, Modbus-TCP, e-mail alarm)
  - optionally: serial interface RS232  
for the connection of a bar code reader (Modbus slave, Modbus master, bar code)
- 

### 2.2 System requirements

The following items are required for operating the serial interface:

- Connecting cable:  
for RS232 / RS485 e.g.  
PC interface  
with TTL/RS232 converter and adapter                      Part No. 70/00350260  
PC interface  
with USB/RS232 converter and adapter                      Part No. 70/00456352  
  
for Ethernet interface, e.g.  
RJ 45 patch cable, CAT 5 or better (crossover)
  - setup or evaluation program, e.g.  
setup program:    Part No. 70/00468991  
PC evaluation software PCA3000                              Part No. 70/00431882  
PCA communications software PCC                              Part No. 70/00431879  
JUMO SVS-2000 visualization:                              data sheet 70.0753
  - PC or notebook
- 

### 2.3 Identifying the interface

The interface for RS232 or RS485 and the Ethernet interface are available in every instrument.

The RS232 serial interface for connecting a bar code reader and the Profibus-DP interface are options.

## 2 General

---

To see whether the instrument already has an additional option interface, use the menu *Device info* → *Hardware* to check.

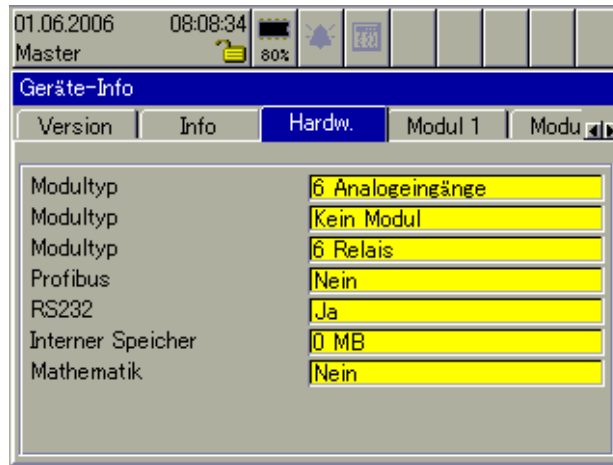

## 3 Connecting the interface

---

### 3.1 Position of the connection

Front panel  
of the  
paperless  
recorder

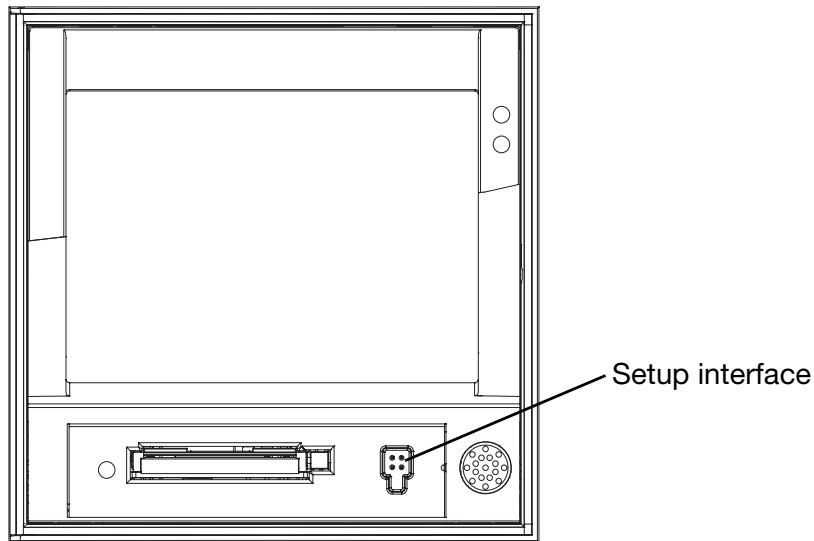

Connection  
diagram



Use either the setup interface on the front panel **or** the setup interface on the back!

The connection on the front panel can only be made through the setup interface with the connecting cable for “PC interface with TTL/RS232 converter and adapter”, Part No. 70/00350260.

If the PC or notebook does not have a serial interface, then the connecting cable “PC interface with USB/RS232 converter and adapter”, is also required (Part No. 70/00456352).

The transmission parameters for the interface are fixed in the instrument, and cannot be altered.

- baud rate = 9600 bps
- data format = 8 data bits, 1 stop bit, no parity

# 3 Connecting the interface

Rear view of the paperless recorder

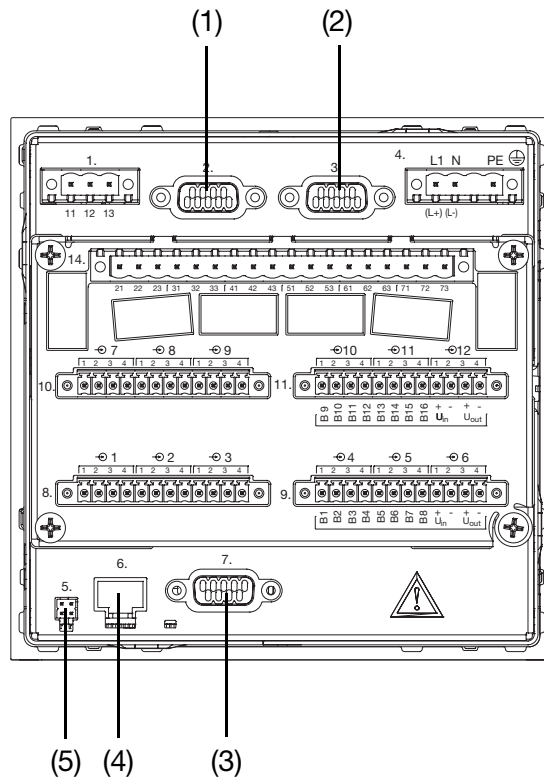

- (1) RS232 interface for bar code reader (option)
- (2) Profibus-DP interface (option)
- (3) RS232/RS485 interface (standard)
- (4) Ethernet interface (standard)
- (5) Setup interface (standard)

Connection diagram RS232/RS485

RS232 (connector (1) + (3))	RS485 (connector (3))
1 ○	1 ○
2 ○ RxD	2 ○
3 ○ TxD	3 ○ TxD+/RxD+
4 ○	4 ○
5 ○ GND	5 ○ GND
6 ○	6 ○
7 ○	7 ○
8 ○	8 ○ TxD-/RxD-
9 ○	9 ○



We recommend using a twisted-pair connecting cable with shielding!  
Only the signal lines shown above are to be connected, otherwise errors will occur.

## 3 Connecting the interface

### 3.2 RS232

In the case of the RS232 interface, the handshake lines (RTS, CTS) are not used. The RTS line from the master (PC or notebook), which is the CTS line for the paperless recorder, will be ignored. The response is sent back immediately by the paperless recorder. The CTS line of the master (RTS on the recorder) remains open.

If the program that is used evaluates the handshake lines, then they must be bridged in the cable.

#### PC COM interface with 9-pin Sub-D socket

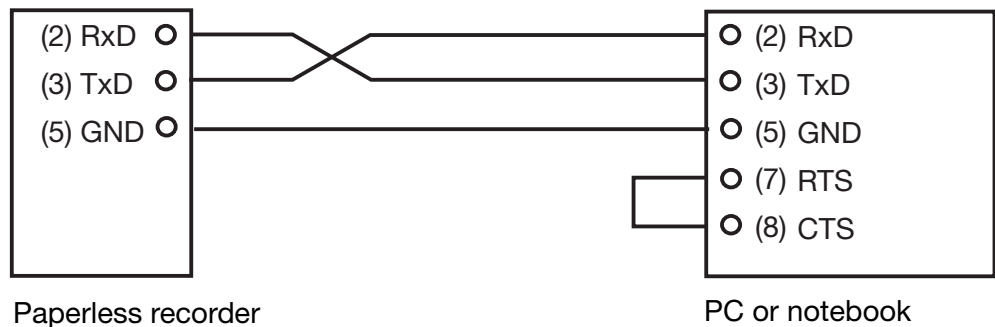

#### PC COM interface with 25-pin Sub-D socket

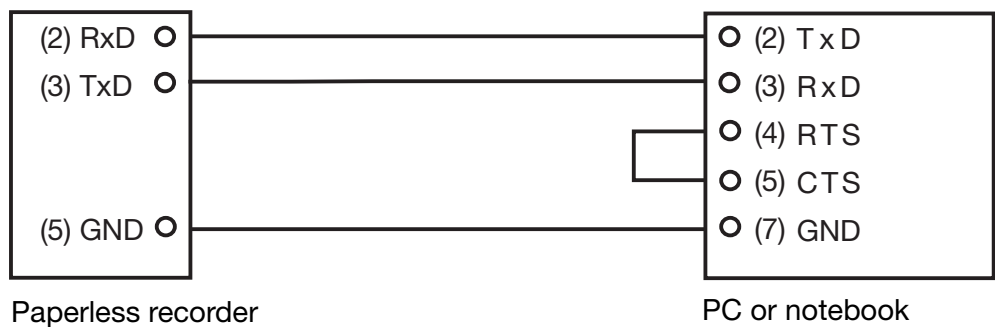

### 3.3 Switching between RS232 and RS485

The changeover between the RS232 and RS485 interfaces is made through the paperless recorder parameter

*Configuration* → *Interfaces* → *Interface1* → *General* → *Type*

or, using the setup program

*Edit* → *serial interface* → *RS232/RS485* → *Type*

# 3 Connecting the interface

## 3.4 Configuration of the serial interfaces

### Configuration on the paperless recorder

- \* On the recorder, select *Configuration* → *Interface* → *Interface 1/2* → *General*.  
The parameters for the configuration of the interface will now be available.

### Configuration through setup program

Configuration with the aid of the setup software is made through the menu item *Edit* → *Interface*.

	Parameter	Value/Selection	Description
Interface type	→ Type	RS232, RS485	Can only be edited for interface 1.  See Chapter 3.3 Switching between RS232 and RS485, page 11
Protocol	→ Protocol	Modbus slave, Modbus master, bar code	see Chapter 5 Serial protocol types, page 33.
Baud rate	→ Baud rate	9600 bps, 19200 bps, 38400 bps	see Chapter 4.3 Timing sequence for communication, page 16.
Transmission mode (RTU)	→ Data format	8-1-none, 8-1-odd, 8-1-even	see Chapter 4.2 Transmission mode (RTU), page 15.
Device address	→ Device address	1 – 254	see Chapter 4.5 Device address, page 18.
Min. response time	→ Min. response time	0 – 500msec	see Chapter 4.3 Timing sequence for communication, page 16.



For communication via the **back panel** RS232 interface and the setup interface, the device address must be observed, even though it is not a bus interface!

The configuration of the setup interface cannot be edited, but is fixed to

- Modbus slave,
- 9600 bps,
- 8-1-none,
- device address 1

The three serial interfaces can be operated simultaneously. There are merely some interlocks built in at the protocol level (e.g. only one setup can be written at a time).

# 3 Connecting the interface

## 3.5 Configuration of the Ethernet interface

**Configuration on the paperless recorder**

is carried out via the menu item *Configuration* → *Interface* → *Ethernet*.

**Configuration via setup program**

is carried out via the menu item *Extras* → *Ethernet interface*.

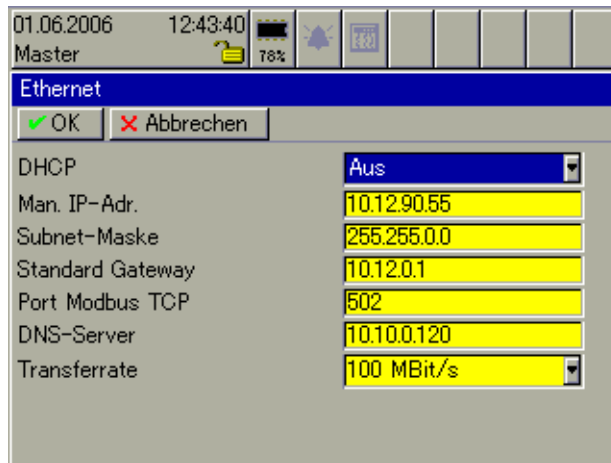

### 3.5.1 Parameters

#### DHCP

DHCP (Dynamic Host Configuration Protocol) is used so that the paperless recorder can automatically receive an IP address and other communication parameters from a DHCP server.

On	DHCP is switched on, the recorder receives its IP address from the DHCP server
----	--

The other communication parameters that the paperless recorder usually receives from the DHCP server include the subnet mask, gateway address, and the lease time.

When the lease time (user time) has expired, the IP address loses its validity. In order that the paperless recorder may always have a valid IP address, it sends a query to its DHCP server whether the address is still valid when 50% of the lease time has expired. If the DHCP server is not available, the recorder repeats the query until 87.5% of the lease time has expired. After that, the recorder sends the query not only to the DHCP server, but to the entire network. If the lease time expires without the IP address being confirmed, the recorder declares the address as invalid and is no longer accessible in the network.

## 3 Connecting the interface

---



An assigned address can be altered by the DHCP server. For example, if the PCA communications software is used for the automatic collection of data, then the address must be altered within the software.

The automatically assigned IP address can be read in the menu *Device manager* → *Device info* → *Eth. Info*.

### Manual IP address

If automatic IP address assignment is not used (DHCP = OFF), then the IP address for the paperless recorder is set up here.

### Subnet mask

If automatic IP address assignment is not used (DHCP = OFF), then the subnet mask is set up here.

The subnet mask is used to gather devices (PC, recorders etc.) together to form subnets. All devices that have an IP address that is AND linked to the subnet mask belong to one subnet and can communicate with one another.

If devices outside the subnet need to be accessed, then the communication must be handled by a gateway (standard gateway).

### Standard gateway

If automatic IP address assignment is not used (DHCP = OFF), then the IP address for the standard gateway is set up here.

The standard gateway is used for communication with devices that do not belong to the subnet.

### Port Modbus TCP

The port address must be set if the paperless recorder needs to be accessed by visualization software, and the Modbus TCP protocol (Modbus tunneling: outer frame = Ethernet, inner frame = Modbus) is to be used.



Any change to this parameter will only become effective after the recorder has been restarted!

### DNS server

This is used to set up the IP address for a DNS server that is installed in the network. The DNS server is required to resolve the name for e-mail transfer via Ethernet.



Any change to this parameter will only become effective after the recorder has been restarted!

### Transfer rate

Here you can configure the transfer rate that is used for communication between the paperless recorder and the DHCP server or other computers.

---

# 4 Modbus protocol description

---

## 4.1 Master-slave principle

When using Modbus/Jbus, the communication between a master (PC or notebook) and a slave device (paperless recorder), takes place according to the master-slave principle, in the form of a data request/instruction - response.

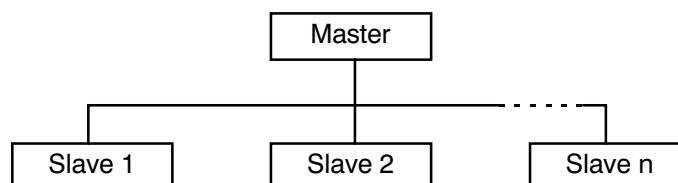

The master controls the data exchange, the slaves only have a response function. They are identified by their device addresses.



The paperless recorder can be operated either as a Modbus slave, see Chapter 5.1 Modbus slave, page 33, or as a Modbus master, see Chapter 5.2 Modbus master, page 35.

In a Modbus network, only **one** device is allowed to take on the master function!

---

## 4.2 Transmission mode (RTU)

The transmission mode used is the RTU mode (Remote Terminal Unit). Data are transmitted in binary format (hexadecimal) with 8 bits, as 16-bit integer values, or as 32-bit float values.

### Data format

The data format describes the structure of a transmitted byte.

Data word	Parity bit	Stop bit	Number of bits
8 bits	none (no)	1	9
8 bits	even	1	10
8 bits	odd	1	10



The data format that is to be used can be selected, see Chapter 3.4 Configuration of the serial interfaces, page 12.

---

# 4 Modbus protocol description

## 4.3 Timing sequence for communication

### Character transmission time

The start and end of a data block are marked by transmission pauses. The character transmission time (the time taken to transmit one character) depends on the baud rate and the data format that is used.

For a data format with 8 data bits, no parity bit and one stop bit, this is:

$$\text{character transmission time [msec]} = 1000 * 9 \text{ bits} / (\text{baud rate})$$

For the other data formats it is:

$$\text{character transmission time [msec]} = 1000 * 10 \text{ bits} / (\text{baud rate})$$

### Example

Baud rate [bps]	Data format [bit]	Character transmission time [msec]
38400	10	0.260
	9	0.234
19200	10	0.521
	9	0.469
9600	10	1.042
	9	0.938

### Timing sequence

A data request runs according to the following timing sequence:

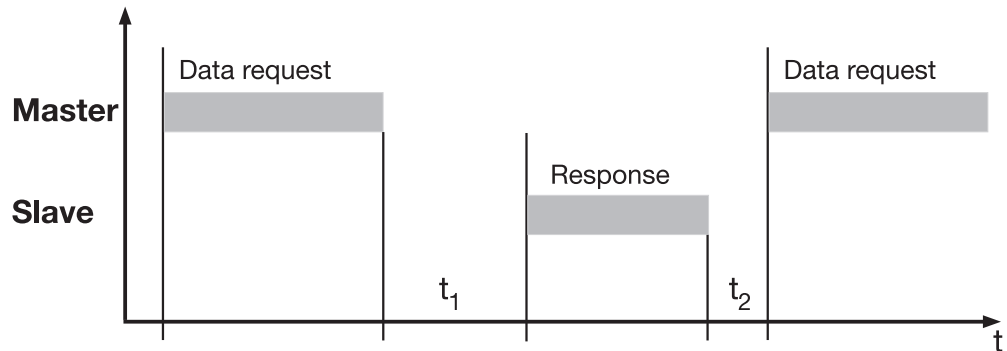

$t_1$  Internal waiting time of the paperless recorder before checking the data request, and the internal processing time.

min.: 5 msec  
 typical: 5 – 45 msec  
 max.: 60 msec, or the preset “minimum response time”

## 4 Modbus protocol description

---



A minimum response time can be set in the controller, in the menu item *Configuration* → *Interface*. This setting is the minimum waiting time that must elapse before an answer is transmitted (0 – 500 msec). If a smaller value is set, then the response time may be longer than the preset value (because the internal processing time is longer), the controller will then answer as soon as the internal processing is completed. A preset time of 0 msec means that the controller answers with the maximum possible speed.

The minimum response time which can be set is required by the RS485 interface in the master, in order to switch over the interface driver from transmit to receive. This parameter is not required for the RS232 interface.

$t_2$  This is the waiting time which the master has to observe before initiating a new data request.

for RS232 at least 3.5 x the transmission time for one character (this time depends on the baud rate)

for RS485 60msec

While  $t_1$  and  $t_2$  are running, the master must not present any further data requests, since the paperless recorder will either ignore them or declare them to be invalid.

---

### 4.4 Structure of a Modbus telegram

**Data structure** All telegrams have the same structure:

Slave address	Function code	Data field	Checksum CRC16
1 byte	1 byte	x byte(s)	2 bytes

Each telegram contains four fields:

**Slave address** the device address of a specific paperless recorder

**Function code** function selection (read/write a word)

**Data field** contains the information (depending on the function code):  
- word address / bit address  
- word number / bit number  
- word value /bit values

**Checksum** detection of transmission errors

---

# 4 Modbus protocol description

---

## 4.5 Device address

The device address for the paperless recorder can be set between 1 and 254 (decimal), see Chapter 3.4 Configuration of the serial interfaces, page 12.



A maximum of 31 paperless recorders can be addressed via the RS485 interface.

Device address 0 is reserved as the Modbus broadcast address. An instruction from the master for address 0 will be carried out by all the slaves, but none of them will answer (because this would lead to a data collision).

If only **one** recorder is connected to the PC or notebook, then it can also be accessed through device address 255 (even if a different address has been configured). The paperless recorder will always respond to instructions for device address 255.

In the transmission protocol, the address is given in binary format (hexadecimal).

---

## 4.6 Function codes

### Function summary

The functions described below can be used to read out measurements and other device and process data from the paperless recorder.

Function number	Function	Restriction
0x01 or 0x02	read n bits	max. 256 bits (16 bytes)
0x03 or 0x04	read n words	max. 127 words (254 bytes)
0x05	write one bit	max. 1 bit
0x06	write one word	max. 1 word (2 bytes)
0x10	write n words	max. 127 words (254 bytes)



If the recorder does not respond to one of these functions, or reacts by generating an error code, then please refer to Chapter 4.9 Error messages, page 25.

---

# 4 Modbus protocol description

## 4.6.1 Read n bits

This function reads n bits, starting from a defined address.

### Data request

Slave address	Function 0x01 or 0x02	Address first bit	Number of bits	Checksum CRC16
1 byte	1 byte	2 bytes	2 bytes	2 bytes

### Response

Slave address	Function 0x01 or 0x02	Number of bits read	bit value(s)	Checksum CRC16
1 byte	1 byte	1 byte	x byte(s)	2 bytes



The response is always made in complete 8-bit bytes.  
The byte values that are not required are filled with the value 0.

### Example

Read one bit, starting at address 0x0340 (word address 0x0034).

For addresses, see Chapter 7.1 Modbus addresses for important device and process data, page 43.

Data request:

01	02	0340	0001	B85A
----	----	------	------	------

Response:

01	02	01	01	6048
			bit value	

## 4.6.2 Read n words

This function reads n words, starting from a defined address.

### Data request

Slave address	Function 0x03 or 0x04	Address of first word	Number of words	Checksum CRC16
1 byte	1 byte	2 byte	2 bytes	2 bytes

### Response

Slave address	Function 0x03 or 0x04	Number of bytes read	Word value(s)	Checksum CRC16
1 byte	1 byte	1 byte	x byte(s)	2 bytes

### Example

Read the first 3 analog inputs (i.e. the first 6 words starting at Modbus address 0x1257).

For the addresses of the analog inputs, see Chapter 7.1 Modbus addresses for important device and process data, page 43.

## 4 Modbus protocol description

---

Data request:

01	03	1257	0006	7160
----	----	------	------	------

Response:

01	03	0C	1999	4348	4CCC	4348	2666	4396	8548
			Measurement 1 200.1	Measurement 2 200.3	Measurement 3 300.3				

---

### 4.6.3 Write one bit

For the “Write one bit” function, the data blocks for instruction and response are identical.

#### Instruction

Slave address	Function 0x05	Bit address	Bit value xx00	Checksum CRC16
1 byte	1 byte	2 bytes	2 bytes	2 bytes
			xx = 00 → bit is set to 0	
			xx = FF → bit is set to 1	

#### Response

Slave address	Function 0x05	Bit address	Bit value	Checksum CRC16
1 byte	1 byte	2 bytes	2 bytes	2 bytes

#### Example

Write one bit, at bit address 0x0340 (i.e. bit 0 of the word address 0x0034).

For addresses, see Chapter 7.1 Modbus addresses for important device and process data, page 43.

Instruction:

01	05	0340	FF00	8DAA
----	----	------	------	------

Response (as instruction):

01	05	0340	FF00	8DAA
----	----	------	------	------

---

## 4 Modbus protocol description

---

### 4.6.4 Write one word

For the “Write one word” function, the data blocks for instruction and response are identical.

Instruction	Slave address	Function 0x06	Word address	Word value	Checksum CRC16
	1 byte	1 byte	2 bytes	2 bytes	2 bytes

Response	Slave address	Function 0x06	Word address	Word value	Checksum CRC16
	1 byte	1 byte	2 bytes	2 bytes	2 bytes

#### Example

Set the variable “External binary In 1” (Modbus address 0x1638) to 1.

For addresses, see Chapter 7.1 Modbus addresses for important device and process data, page 43.

Instruction:

01	06	1638	0001	CD8F
----	----	------	------	------

Response (as instruction):

01	06	1638	0001	CD8F
----	----	------	------	------

### 4.6.5 Write n words

Instruction	Slave address	Function 0x10	Address of first word	Number of words	Number of bytes	Word value(s)	Checksum CRC16
	1 byte	1 byte	2 bytes	2 bytes	1 byte	x byte(s)	2 bytes

Response	Slave address	Function 0x10	Address of first word	Number of words	Checksum CRC16
	1 byte	1 byte	2 bytes	2 bytes	2 bytes

#### Example

Write the word “Test” (ASCII coding: 0x54 0x65 0x73 0x74 0x00) to the address 0x148 ff, so that this text is entered in the event list for group 1:

Instruction:

01	10	148A	0003	06	54 65 73 74 00 00	9BFA
----	----	------	------	----	-------------------	------

Response:

01	10	148A	0003	A412
----	----	------	------	------

# 4 Modbus protocol description

## 4.7 Transmission format (integer, float, double and text values)

**Integer values** When using Modbus, integer values are transmitted in the following format: first the HIGH byte, then the LOW byte.

**Example** Request the integer value from address 0x1017, when this address contains the value “4” (word value: 0x0004).  
 Request: 01031017000130CE (CRC16 = CE30)  
 Response: 010302**0004**B987 (CRC16 = 87B9)

**Float values** When using Modbus, float values are processed in the IEEE 754 standard format (32-bit), but with the difference that bytes 1 and 2 are swapped with bytes 3 and 4.

**Single float format (32-bit) according to standard IEEE 754**

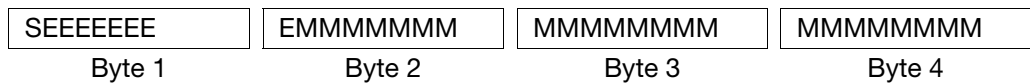

S = sign bit  
 E = exponent (complement to base 2)  
 M = 23bit normalized mantissa

**Modbus float format**

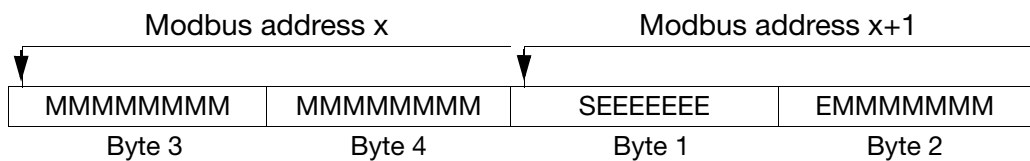

**Example** Request the float value from address 0x0035, when this address contains the value “550.0” (0x44098000 in IEEE 754 format).  
 Request: 140300350002D6C0 (CRC16 = C0D6)  
 Response: 140304**80004409**6434 (CRC16 = 3464)

After the transmission from the device, the bytes of the float value must be swapped accordingly.



Many compilers (e. g. Microsoft Visual C++) store the float values in the following order:

**Float value**

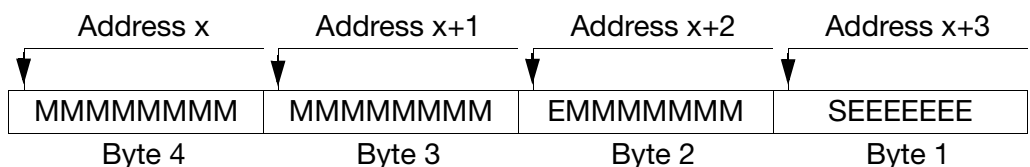

Please check how float values are stored in your application. If necessary, the bytes will have to be swapped accordingly in your interface program, after they have been fetched from the paperless recorder.

# 4 Modbus protocol description

## Double values

When using Modbus, double values are also processed in the IEEE-754 standard format (32bits). Unlike float values, no bytes are swapped for double values.

### Double float format (32-bit) according to standard IEEE 754

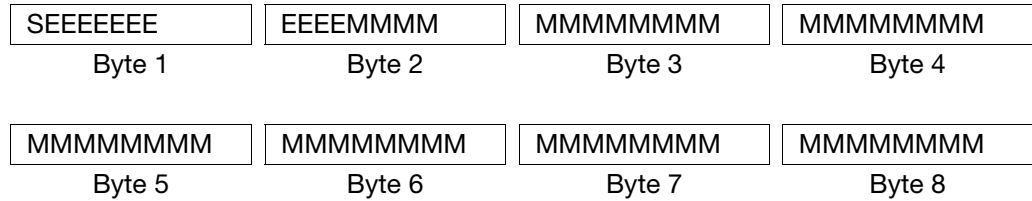

S = sign bit  
 E = exponent (complement to base 2)  
 M = 52 bit normalized mantissa

### Modbus double format

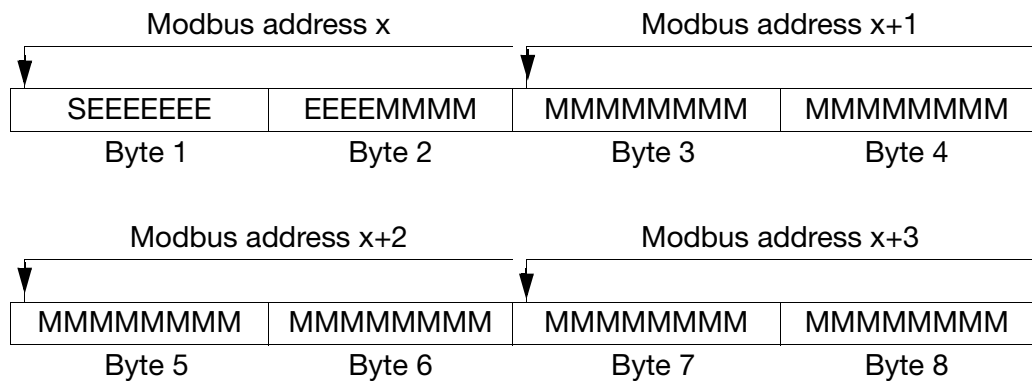

## Example

Request the double value from address 0x0066, when this address contains the value "1234567.89" (0x4132D687E3D70A3D in IEEE 754 format).

Request: 140300660004A6D3 (CRC16 = D3A6)

Response: 1403084**132D687E3D70A3DE**1C1 (CRC16 = C1E1)



Please check how double values are stored in your application. If necessary, the bytes will have to be swapped accordingly in your program, after they have been fetched from the paperless recorder.

# 4 Modbus protocol description

---

## Character strings (texts)

Character strings are transmitted in ASCII format.

 An "0" (ASCII code 0x00) must always be transmitted as the last character, to mark the end of the string. Any following characters are meaningless.

Since text transmission is made as words (16-bit), if there is an odd number of characters (incl. "0"), an additional 0x00 will be added on.

The maximum lengths given in the address tables (See "Address tables" on page 43. ff) for character strings include the terminating "0". I.e. the text for "char 11" can have a maximum length of 10 readable characters.

---

## Example

Request the text from address 0x1000, if this address contains the character string "LS NT" (ASCII code: **0x4C, 0x53, 0x20, 0x4E, 0x54, 0x00**).

Request: 01031000000440C9

Response: 010308**4C53204E54**0000AA0D96

 Instead of "AA" in front of the CRC sum, there could be any value – since it comes after the "0", it will be ignored.

---

## 4.8 Checksum (CRC16)

### Calculation method

The checksum (CRC16) is used to recognize transmission errors. If an error is detected during evaluation, the corresponding device will not respond.

CRC = 0xFFFF	
CRC = CRC XOR ByteOfMessage	
For (1 to 8)	
CRC = SHR(CRC)	
if (flag shifted right = 1)	
then	else
CRC = CRC XOR 0xA001	
while (not all ByteOfMessage processed);	

 The low byte of the checksum is transmitted first.

## 4 Modbus protocol description

---

### Example 1

Request status of relay output 1.

Instruction: read one word from address 0x1631

01	03	1631	0001	D18D
----	----	------	------	------

Response (CRC = 0x8479):

01	03	02	0001	7984
			Word 1	

Word 1 = 1 indicates that relay 1 is active.

---

## 4.9 Error messages

### 4.9.1 Modbus error codes

#### No response from the recorder

The slave will not respond if one of the following errors occurs:

- the baud rate or data format for the master (PC or notebook) does not match the slave (paperless recorder)
- the device address for the recorder does not match the address contained in the protocol
- the checksum (CRC16) is not correct
- the instruction from the master is incomplete or over-defined
- the number of words to be read is zero

In these cases, when the time-out of 2 seconds has expired, the data will have to be retransmitted.

#### Error codes

If the data request from the master is received by the paperless recorder without any transmission error, but cannot be processed, then the recorder will answer with an error code.

The following error codes may appear:

- 01 invalid error code
- 02 invalid address or too many words or bits to be read or written
- 03 value is outside the permitted range
- 08 write-protected value

## 4 Modbus protocol description

---

**Response in the event of an error**

Slave address	Function XX OR 80h	Error code	Checksum CRC16
1 byte	1 byte	1 byte	2 bytes

The function code is OR-ed with 0x80, which means that the MSB (most significant bit) is set to 1.

**Example**

Data request:

01	06	1257	0001	FCA2
----	----	------	------	------

Response:

01	86	08	43A6
----	----	----	------

Response is error code 08, because address 0x1257 is write-protected.

---

### 4.9.2 Error messages for invalid values

For measurements in float format, the error number is shown in the value itself, i.e. the error number is entered instead of the measurement.

Error code for float values	Errors
1.0 x 10 <sup>37</sup>	underrange
2.0 x 10 <sup>37</sup>	overrange
3.0 x 10 <sup>37</sup>	no valid input value
4.0 x 10 <sup>37</sup>	division by zero
5.0 x 10 <sup>37</sup>	math error
6.0 x 10 <sup>37</sup>	invalid terminal temperature for TE
7.0 x 10 <sup>37</sup>	invalid float value
8.0 x 10 <sup>37</sup>	integrator or statistics destroyed

## 4 Modbus protocol description

---

### Example

Data request:

01	03	1259	0002	1160
----	----	------	------	------

Response:

01	03	04	8E52	7DB4	51ED
----	----	----	------	------	------

The measurement 0x7DB48E52 (=  $3.0 \times 10^{37}$ ) delivered by analog input 2 (Modbus address 0x1259) shows that the input value is invalid.

---

### 4.9.3 JUMO error codes as integer return values

For some lengthy sequences, such as the transfer of a program to a JUMO controller or e-mail delivery, an error code is entered in an event field or the event list at the end. The error codes are the same for all JUMO instruments.

### Error codes

---

Error code	Description
<b>Error list: Program memory management</b>	
1	program cannot be created
2	program not available
3	program cannot be deleted
4	segment cannot be deleted
5	checksum cannot be saved
6	checksum cannot be read
7	program cannot be copied
8	segment cannot be copied
9	program checksum error
10	program pointer tab. checksum error
11	program memory end
12	segment not available
13	repeat jump mark cannot be corrected

## 4 Modbus protocol description

---

Error code	Description
<b>Error list: General input and output</b>	
14	please confirm with the ENTER key
15	invalid number of places
16	the entry contains invalid characters
17	value is outside the limits
18	segment not programmed correctly
19	password error
<b>Error list: Profibus job processing</b>	
20	busy flag from master not reset
21	impermissible job
22	error on data acceptance
23	no cyclical data available
24	structure length is not permitted
25	header ID is not permitted
<b>Error list: Keypad and program lock</b>	
26	keypad is locked
27	programming is inhibited
28	error in ser. EEPROM (calib)
29	hardware error: HAND + AUTO locked
30	editing not permitted when program is active
31	copying not permitted when program is active
32	HAND is not permitted during AUTO delay time
33	segment change! Screen must be generated
34	no DB number for screen generation from PLC
35	no DB number for process values from PLC
36	printer busy or not ready
37	setpoint 1 was not programmed
38	set up the printer (config. / interface)
39	only possible when device is in HAND mode
40	self-optimization already running
41	time axis expired or not programmed

## 4 Modbus protocol description

---

Error code	Description
42	time axis cannot be copied
43	time axis not available
44	program alteration is inhibited
45	HAND mode is locked
46	program start is locked
<b>Error list: Interface processing</b>	
47	wrong response length
48	time-out error (no response)
49	error reported in telegram protocol
50	checksum error
51	parity error
52	frame error
53	interface buffer full
54	address error (for instance: address not available)
55	wrong or unexpected command
<b>Error list: Event processing</b>	
60	event could not be created
61	event setting failed
62	event clear failed
63	event wait failed
64	event close failed
65	event open failed
66	sync error between group and data manager
<b>Error list: Message processing</b>	
70	no queue memory available
71	message queue cannot be opened
72	message pool cannot be created
73	memory from message pool cannot be requested
74	message cannot be sent

## 4 Modbus protocol description

---

Error code	Description
<b>Error list: Handling of MQX functions</b>	
80	task creation failed
81	hardware timer not created
<b>Error list: Flash processing</b>	
90	write error for data flash
<b>Error list: Other errors</b>	
100	undefined error
101	division by zero
102	cannot find RAM
103	RTC run-time overrun
104	ID does not exist
105	index too large (overflow)
106	data not valid
107	invalid pointer
109	string without zero characters
110	time-out (overrun) during initialization
111	value write forbidden
112	log entry with error bits that initiate debug mode
<b>Error list: E-mail dispatch via modem and Ethernet</b>	
120	step error in status automatic
121	invalid response length
122	no CONNECT from modem
123	FCS checksum error
124	unexpected value or response
125	CONF request not accepted
126	no CONF request from other end
127	no CHAP request from other end
128	response time-out
129	unknown modem response
130	unexpected OK from modem
131	unexpected CONNECT from modem

## 4 Modbus protocol description

---

<b>Error code</b>	<b>Description</b>
132	unknown frame received
133	unexpected PROTOCOL from modem
134	unexpected COMPRESS from modem
135	invalid PPP packet received
136	unexpected BUSY from modem
137	unknown authentication protocol
138	ignored LCP option
139	unexpected DELAYED from modem
140	unexpected NODIALTONE
141	unknown PPP protocol
142	unknown PAP code
143	ignored IPCP option
144	ignored IPCP code
145	unknown CHAP code
146	IP checksum error
147	unknown IP protocol
148	unknown ICMP type
149	unknown LCP type
150	received as client DNS request
151	unknown DNS error
152	DNS response is divided
153	no IP received by DNS
154	unknown Udp port
155	TCP checksum error
156	TCP port error
157	unknown TCP-SYN option
158	unused TCP port
159	unknown POP3 response
160	unknown SMTP response
161	unknown DNS name
162	no MD5 requested for CHAP

## 4 Modbus protocol description

---

Error code	Description
163	authentication error
164	cancel from other end
165	error on creating TCP socket
166	error on binding TCP socket
167	error on TCP CONNECT
168	error in TCP telegram transmission
169	error on closing TCP socket
170	error on TCP listing
171	reset on TCP ACCEPT
172	error on TCP ACCEPT
173	SMTP server reports syntax error
<b>Error list: File system processing</b>	
200	error during installation of partition manager
201	error during installation of MFS file system
202	error during de-installation of partition manager
203	error during de-installation of MFS file system

---

# 5 Serial protocol types

## 5.1 Modbus slave

If the JUMO Logoscreen nt has been configured as a slave (see Chapter 3.4 Configuration of the serial interfaces, page 12) it will respond to a Modbus request from the master in the network.

The master controls the data exchange, the slaves only have a response function. They are identified by their device addresses.

The master is usually a PC with a setup program or a visualization program. The master can request all the device variables of the JUMO Logoscreen nt (see Chapter 7 Address tables, page 43).

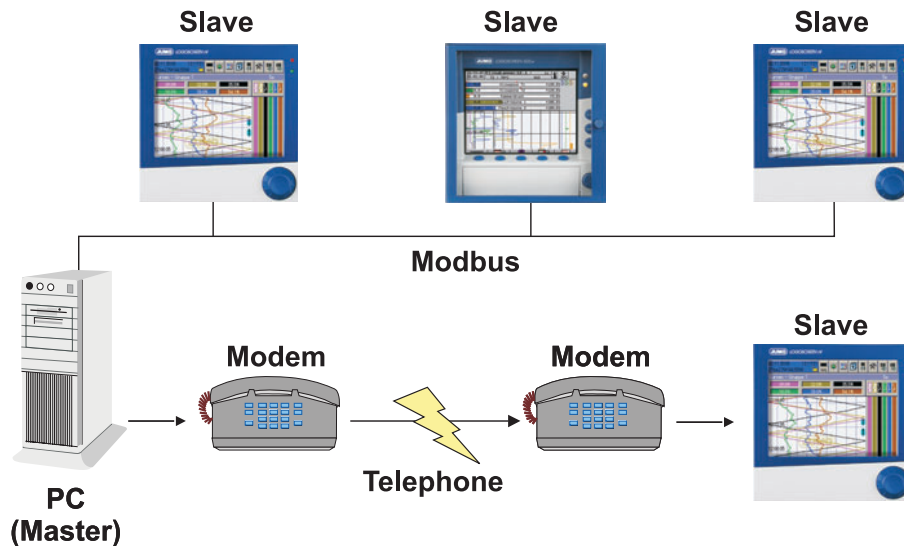

In a Modbus network, only **one** device is allowed to take on the master function!

### Modem operation

- A Logoscreen nt in slave mode can be controlled by the master via a modem over a telephone line, see the picture above.
- The paperless recorder can initialize a modem itself (also cyclically, for the situation where the modem is switched on after the instrument).
- The recorder can use the INIT string (entry with the setup program in the mask "RS232/RS485: Modem") to configure the modem so that it will automatically accept ("pick up") an incoming call. The recorder can then be remotely interrogated by the master, using Modbus commands, or send a signal (e.g. an alarm) or an e-mail after active dial-up.
- Using a dial-up/hang-up string, the paperless recorder (slave) can send an alarm to a PC (master) with the JUMO SVS-2000 software. The JUMO SVS-2000 software detects incoming modem calls.
- Using a dial-up/hang-up string, the paperless recorder (slave) can also call an Internet provider and send an e-mail.

When modem operation is active, the following parameters can be edited (only through the setup program):

# 5 Serial protocol types

## Modem parameters

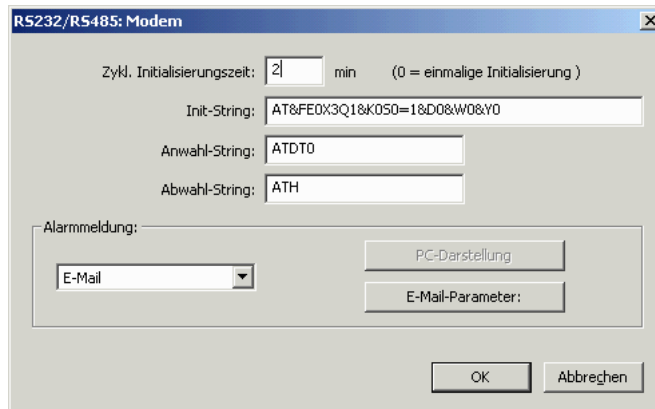

The following INIT string is required for operation as a Modbus slave via modem:

`AT&FE0X3Q1&K0S0=1&D0&W0&Y0`

- AT&F = load present manufacturer profile
- E0 = switch off character echo
- X3 = switch off fixed dial tone selection,  
switch on busy tone selection
- Q1 = switch off command responses
- &K0 = switch off data flow control
- S0=1 = automatic pick-up after first ring
- &D0 = ignore DTR signal
- &W0 = save present configuration as profile 0
- &Y0 = use user profile 0 after switch-on

The dial-up/hang-up strings are only required if one of the modem alarms is activated.

## Internet dial-up

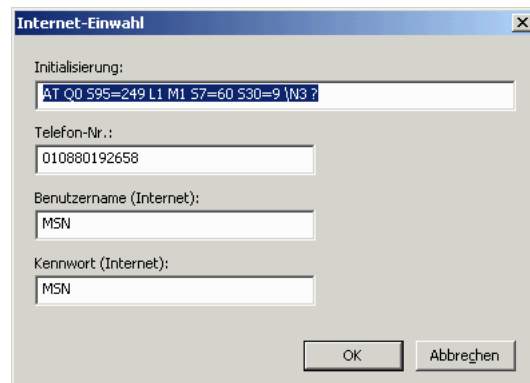



For active dial-up to the Internet for alarms by e-mail, the device modem must be switched into a different mode, using another INIT string.

The telephone number, user name and password must be entered so that they match the details for the selected Internet provider.

When the dial-up procedure to the Internet has been completed, the modem will automatically be reset to the initial state, using the INIT string that was entered in “Modem parameters”.

### E-mail parameters

E-Mail-Adresse:

1 Empfaenger1@domain.de

2 Empfaenger2@domain.de

3

1 2 3 4 5

Alarmsignal: Ext. Binäreingang 1

Antwort:  
Mail-Betreff 1

Inhalt:  
Mail-Text 1

Erweiterte Parameter

Mail-Server Nur von Fachpersonal zu ändern !

Internet-Einwahl Die Werkseinstellung ist bereits lauffähig !

OK Abbrechen

## 5.2 Modbus master

If the JUMO Logoscreen nt has been configured as a master, (see Chapter 3.4 Configuration of the serial interfaces, page 12) it can send Modbus requests to the slaves in the network (e.g. other recorders). The values that are requested will be written to the external device variables of the Logoscreen nt:

- external analog values 1 to 24 in the analog selector
- external binary values 1 to 24 in the binary selector

# 5 Serial protocol types

- external texts 1 to 9 (e.g. in order to combine batch texts in the instrument)

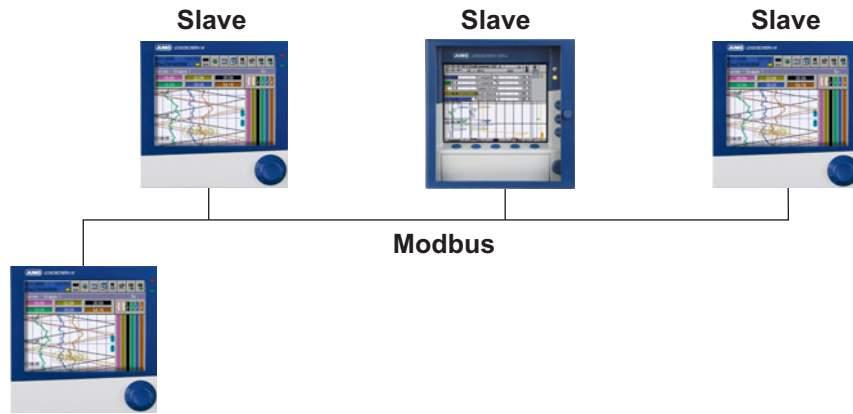

**Logoscreen nt  
(Master)**

## Modbus master

The screenshot shows a configuration window titled 'RS232/RS485: Modbus-Master'. It is divided into three sections for different data types:

- Adr. ext. Analogwert:** Includes a list of 11 external addresses (1-11), a 'Geräteadresse' field set to 0, a 'Modbus-Adresse' field set to 0x0000, an 'Anzahl der Messwerte' field set to 1, and a 'Wort-Übertragung' dropdown menu set to 'MSB zuerst'.
- Adr. ext. Binärwert:** Includes a list of 11 external addresses (1-11), a 'Geräteadresse' field set to 0, a 'Modbus-Adresse' field set to 0x0000, a 'Bit-Nummer' field set to 0, and a 'Bit-Anzahl' field set to 1.
- Adr. ext. Text:** Includes a list of 9 external addresses (1-9), a 'Geräteadresse' field set to 0, a 'Modbus-Adresse' field set to 0x0000, and a 'Wortanzahl' field set to 1.

At the bottom, there are fields for 'Zeitüberschreitung' (700 ms) and 'Abfragezyklus' (500 ms), along with 'OK' and 'Abbrechen' buttons.



These parameters can be edited in the setup program and on the Logoscreen nt.

For each target variable, you can enter the device address and the Modbus address from which the value will be requested.

Every programmed request can be switched to inactive by entering the device address 0 (e.g. if “external analog value 5” is no longer to be written by the Modbus master, but from the Profibus).



Double writing of a target variable will lead to undefined states, and must be avoided!

## 5 Serial protocol types

---

For analog and binary values, the entry of “Number of measurements” or “Number of bits” greater than 1 allows one command to read several variables, one after another. On saving, the following target variables will automatically be utilized.

---

**Time-out** defines the maximum waiting time for a response after the transmission of each command before the next command is implemented.

---

**Polling cycle** defines the time interval between a read-in of the variables and the next read.

---

### 5.3 Bar code

In “Bar code mode” (see Chapter 3.4 Configuration of the serial interfaces, page 12), the JUMO Logoscreen nt appears as a Slave. It waits for the ASCII string that is transmitted by the bar code reader (master).

This interface mode merely requires the setting of the configuration parameters “Baud rate” and “Data format”, see Chapter 3.4 Configuration of the serial interfaces, page 12 – no other parameters are needed in this case.

These strings can be used by the paperless recorder for the step-by-step control of a batch sequence (see Operating Manual 70.6580.0.0, Chapter 4.9).

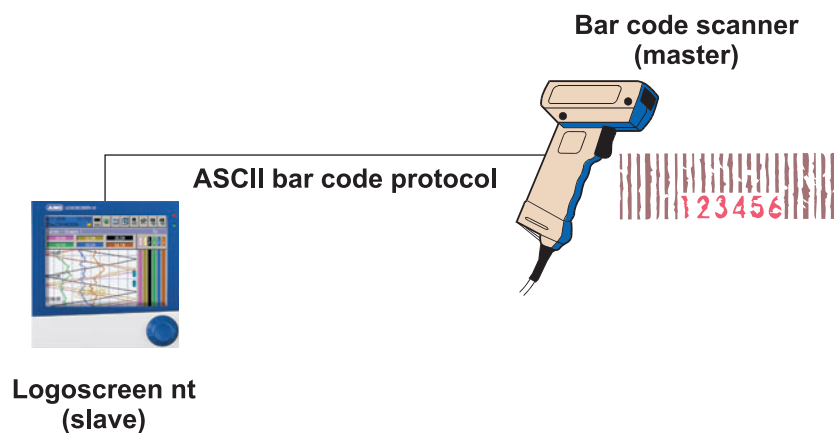

The advantage of an Ethernet connection compared with a serial connection lies in the higher transmission rate and the company-wide accessibility.

---

### 6.1 HTTP

In this case, the Logoscreen nt is configured as a slave, and handles the incoming queries as a server through port 80. These queries could, for instance, come from a PC with the setup software, PC evaluation software (PCA) or PCA communications software (PCC).

---

### 6.2 Browser connection

The Logoscreen nt can also be accessed by a browser, using the HTTP protocol. The URL required for this purpose is the IP address of the recorder.

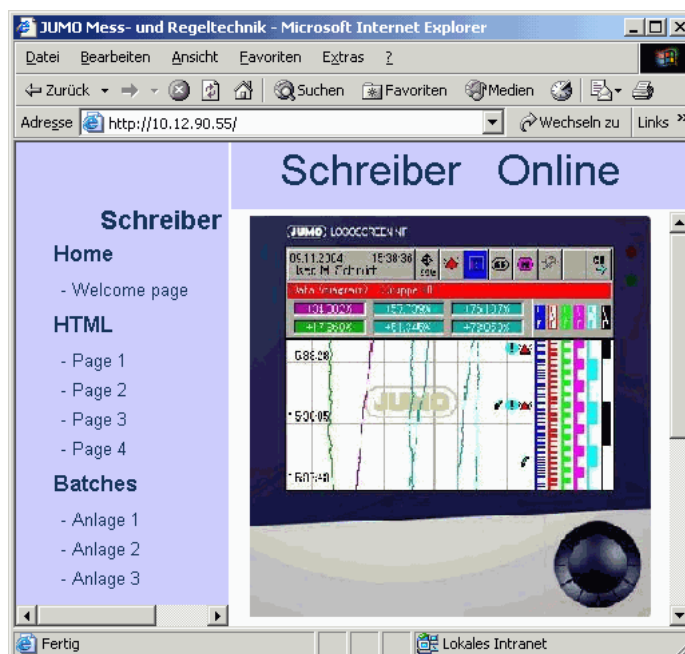

This is used to access the HTML home page “index.htm”, and from here it can branch to the other HTML pages.

Using the setup program *Edit* → *Web server directories* → *Web import*, the start page “index.htm” and other HTML pages can be downloaded to the Logoscreen nt. 512 kB of memory are available for this purpose.

Three HTML process diagrams and three HTML batch pages are stored as templates in the ex-factory instrument.

Device variables can be accessed by special tags in the HTML pages. Support is provided in a Help window for the setup program, in which the device variable can be selected and the corresponding HTML tag copied to the clipboard.

## 6.3 Modbus-TCP

In this case, the Logoscreen nt is configured as a slave, and handles the incoming queries as a server through port 502. The port can also be changed, see Chapter 3.5 Configuration of the Ethernet interface, page 13.

Modbus-TCP is a standardized procedure for packing a Modbus telegram inside a TCP frame (tunneling) and transmitting it via Ethernet.

The Modbus telegram (without CRC) is transmitted with an additional, 6 or 7 byte long MBAP header. The seventh byte corresponds to the first serial byte, but has a different designation in this case.

### Structure of a Modbus-TCP telegram

MBAP header				Modbus telegram
2 bytes transaction ID	2 bytes protocol ID	2 bytes length	1 byte unit ID	other bytes as below, but without CRC
Identical for request and response	Must be 0 for Modbus	Length of query or response in bytes from (incl.) unit ID	Corresponds to device address. For TCP, must be 0xFF or 0 (0 = broadcast)	

As a comparison: the normal Modbus telegram, see Chapter 4.4 Structure of a Modbus telegram, page 17:

Slave address 1 byte	Function code 1 byte	Data field x bytes	CRC16 2 bytes
-------------------------	-------------------------	-----------------------	------------------

This protocol can be used, for instance, by the JUMO SVS 2000 visualization program (or similar programs) to read from and write to the Logoscreen nt over a company-wide Ethernet network. It is possible to access all the device variables in the Modbus address tables (see Chapter 7 Address tables, page 43).



Only one Modbus master (client) at a time can access a Logoscreen nt by means of the Modbus-TCP.

A connection that has been opened by a client will be closed after 30 seconds of inactivity!

A closed Modbus-TCP port (from the Logoscreen nt or the other end) can only be opened again after 10 seconds.

# 6 Ethernet protocols

## 6.4 E-mail (SMTP and POP3)

The Logoscreen nt can send out e-mails (e.g. alarms). In this case, it is the master (client) and can access an SMTP server through the standard port (25) as well as a POP3 server through the standard port (110).

### Typical networking in a company network

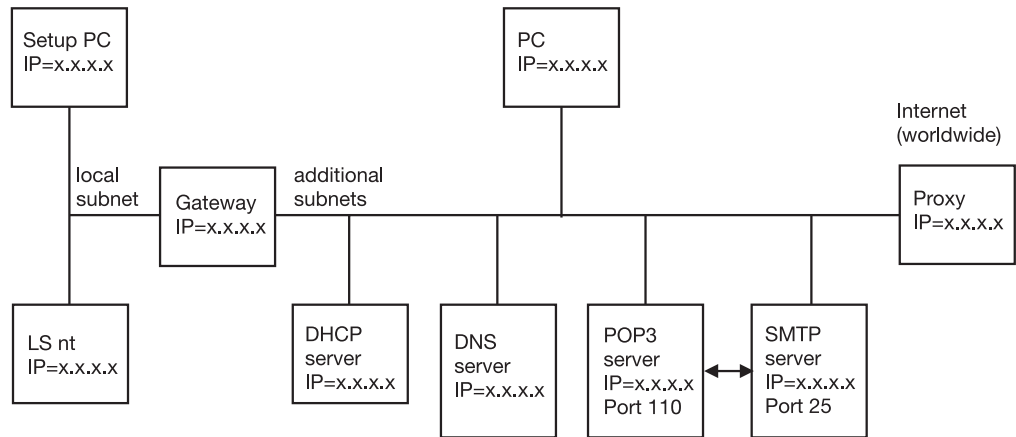

### Function of the individual nodes

#### Gateway

separates local subnets from one another, and thus provides a filtering of the packets. Not every packet is received in every subnet. Packets from outside the local subnet must be addressed to the gateway.

#### DHCP server

can automatically assign the IP address, subnet mask and gateway address for other nodes at switch-on. These parameters can also be entered manually, and then a DHCP server is not necessary.

#### DNS server

converts symbolic names into IP addresses, e.g. the query: "www.name.de" will generate the response "www.name.de has IP=10.12.32.45".

#### POP3 server

is used to read out received e-mails for a mail account. The POP3 mail account can be accessed after logging in with a user name and a password. A successful log-in procedure will often also enable the transmission authorization for an attached SMTP server.

#### SMTP server

is used for sending e-mails. In many networks, the authorization for transmission via a mail account must first of all be enabled by a log-in to the corresponding POP3 server.

#### Proxy

serves as a gateway between the local company network and the Internet. This is also the place where the local IP addresses (as used in the company network) are converted into unique IP addresses (as used on the Internet). The Logoscreen nt software cannot address a proxy!

## Parameters for the mail server and e-mail

These parameters can only be edited through the setup program:  
*Edit → E-mail parameters*

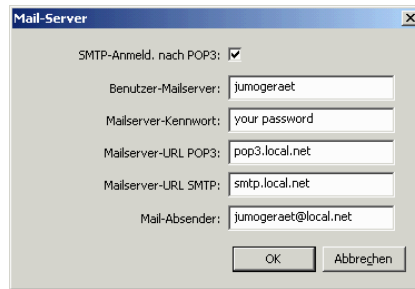

The 'Mail-Server' dialog box contains the following fields and options:

- SMTP-Anmeld. nach POP3:
- Benutzer-Mailserver: jumogeraet
- Mailserver-Kennwort: your password
- Mailserver-URL POP3: pop3.local.net
- Mailserver-URL SMTP: smtp.local.net
- Mail-Absender: jumogeraet@local.net

Buttons: OK, Abbrechen

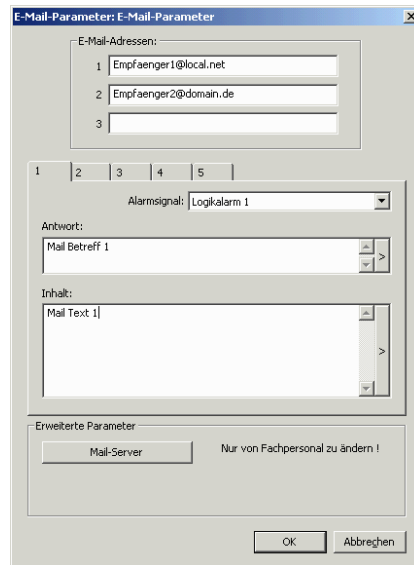

The 'E-Mail-Parameter: E-Mail-Parameter' dialog box contains the following sections:

- E-Mail-Adressen:
  - 1 Empfaenger1@local.net
  - 2 Empfaenger2@domain.de
  - 3
- Alarmsignal: Logikalarm 1
- Antwort: Mail Betreff 1
- Inhalt: Mail Text 1
- Erweiterte Parameter: Mail-Server (Nur von Fachpersonal zu ändern !)

Buttons: OK, Abbrechen



Here you must enter a mail server that is located within the company network (not on the Internet)! This mail server should also have the capability of passing on e-mails to the Internet.

# 6 Ethernet protocols

## Sending an e-mail via the Internet

Many of the steps here depend on the device parameters that have been configured. From the error code for the event entry (see Chapter 4.9.3 JUMO error codes as integer return values, page 27), particularly error codes 120 to 173, it is possible to deduce that a parameter has been set incorrectly. For instance, an incorrectly entered IP for the DNS server produces the error code 153 = "no IP received by DNS".

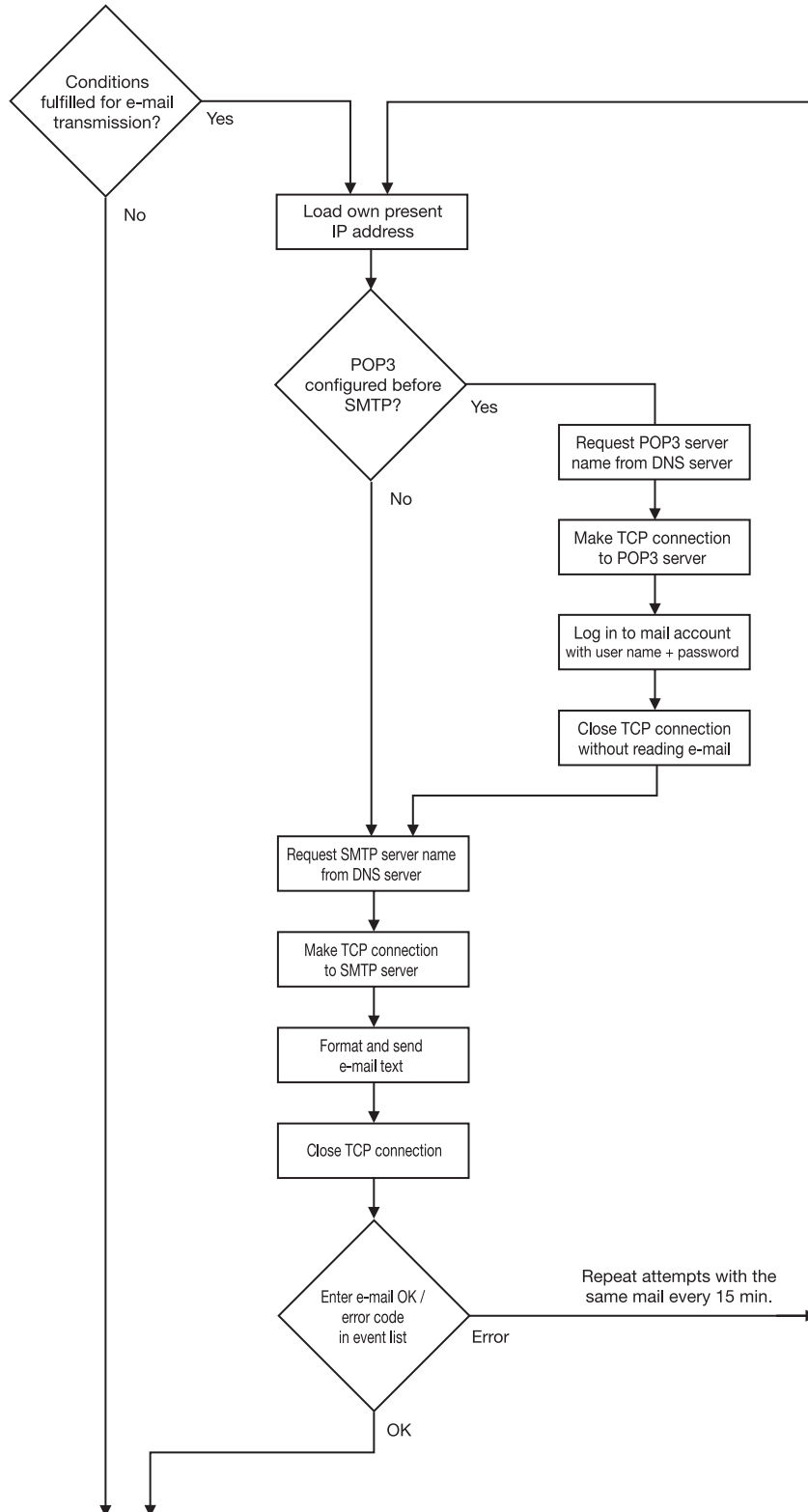

## 7 Address tables

---

All process values (variables) together with their addresses, data types and access modes are described below.

References are as follows:

R	read access only
W	write access only
R/W	read and write access
char	ASCII character (8 bits)
byte	byte (8 bits)
int	integer (16 bits)
char xx	character string of length xx; xx = length, including the string termination character "0"
bit x	bit No. x
float	float value (4 bytes)
double	double value (8 bytes)
bool	boolean variable

The process values are divided into logical groups.

In the following address tables, bit 0 is always the least significant bit.

### 7.1 Modbus addresses for important device and process data

Address	Access	Data type	Signal designation
0x0009	R	char 12	software version
0x1000	R	char 46	device name
0x1017	R/W	byte	display brightness
0x120F	R	long	hardware count 1
0x1211	R	long	hardware count 2
0x1213	R	long	hardware count 3
0x1215	R	long	hardware count 4
0x1217	R	long	hardware count 5
0x1219	R	long	hardware count 6
0x121B	R	char 11	software version, card 1
0x1221	R	char 11	software version, card 2
0x1227	R	char 11	software version, card 3
0x122D	R	char 11	software version, Profibus

## 7 Address tables

---

Address	Access	Data type	Signal designation
0x1257	R	float	filtered analog value 1
0x1259	R	float	filtered analog value 2
0x125B	R	float	filtered analog value 3
0x125D	R	float	filtered analog value 4
0x125F	R	float	filtered analog value 5
0x1261	R	float	filtered analog value 6
0x1263	R	float	filtered analog value 7
0x1265	R	float	filtered analog value 8
0x1267	R	float	filtered analog value 9
0x1269	R	float	filtered analog value 10
0x126B	R	float	filtered analog value 11
0x126D	R	float	filtered analog value 12
0x126F	R	float	filtered analog value 13
0x1271	R	float	filtered analog value 14
0x1273	R	float	filtered analog value 15
0x1275	R	float	filtered analog value 16
0x1277	R	float	filtered analog value 17
0x1279	R	float	filtered analog value 18
0x127B	R	bool	analog alarm 1, channel 1
0x127C	R	bool	analog alarm 1, channel 2
0x127D	R	bool	analog alarm 1, channel 3
0x127E	R	bool	analog alarm 1, channel 4
0x127F	R	bool	analog alarm 1, channel 5
0x1280	R	bool	analog alarm 1, channel 6
0x1281	R	bool	analog alarm 1, channel 7
0x1282	R	bool	analog alarm 1, channel 8
0x1283	R	bool	analog alarm 1, channel 9
0x1284	R	bool	analog alarm 1, channel 10
0x1285	R	bool	analog alarm 1, channel 11
0x1286	R	bool	analog alarm 1, channel 12
0x1287	R	bool	analog alarm 1, channel 13
0x1288	R	bool	analog alarm 1, channel 14
0x1289	R	bool	analog alarm 1, channel 15
0x128A	R	bool	analog alarm 1, channel 16
0x128B	R	bool	analog alarm 1, channel 17
0x128C	R	bool	analog alarm 1, channel 18
0x128D	R	bool	analog alarm 2, channel 1
0x128E	R	bool	analog alarm 2, channel 2
0x128F	R	bool	analog alarm 2, channel 3
0x1290	R	bool	analog alarm 2, channel 4
0x1291	R	bool	analog alarm 2, channel 5
0x1292	R	bool	analog alarm 2, channel 6
0x1293	R	bool	analog alarm 2, channel 7
0x1294	R	bool	analog alarm 2, channel 8
0x1295	R	bool	analog alarm 2, channel 9
0x1296	R	bool	analog alarm 2, channel 10

## 7 Address tables

Address	Access	Data type	Signal designation
0x1297	R	bool	analog alarm 2, channel 11
0x1298	R	bool	analog alarm 2, channel 12
0x1299	R	bool	analog alarm 2, channel 13
0x129A	R	bool	analog alarm 2, channel 14
0x129B	R	bool	analog alarm 2, channel 15
0x129C	R	bool	analog alarm 2, channel 16
0x129D	R	bool	analog alarm 2, channel 17
0x129E	R	bool	analog alarm 2, channel 18
0x12AA	R	float	external, limit-checked, analog value 1
0x12AC	R	float	external, limit-checked, analog value 2
0x12AE	R	float	external, limit-checked, analog value 3
0x12B0	R	float	external, limit-checked, analog value 4
0x12B2	R	float	external, limit-checked, analog value 5
0x12B4	R	float	external, limit-checked, analog value 6
0x12B6	R	float	external, limit-checked, analog value 7
0x12B8	R	float	external, limit-checked, analog value 8
0x12BA	R	float	external, limit-checked, analog value 9
0x12BC	R	float	external, limit-checked, analog value 10
0x12BE	R	float	external, limit-checked, analog value 11
0x12C0	R	float	external, limit-checked, analog value 12
0x12C2	R	float	external, limit-checked, analog value 13
0x12C4	R	float	external, limit-checked, analog value 14
0x12C6	R	float	external, limit-checked, analog value 15
0x12C8	R	float	external, limit-checked, analog value 16
0x12CA	R	float	external, limit-checked, analog value 17
0x12CC	R	float	external, limit-checked, analog value 18
0x12CE	R	float	external, limit-checked, analog value 19
0x12D0	R	float	external, limit-checked, analog value 20
0x12D2	R	float	external, limit-checked, analog value 21
0x12D4	R	float	external, limit-checked, analog value 22
0x12D6	R	float	external, limit-checked, analog value 23
0x12D8	R	float	external, limit-checked, analog value 24
0x12DA	R/W	float	external analog value, interface 1
0x12DC	R/W	float	external analog value, interface 2
0x12DE	R/W	float	external analog value, interface 3
0x12E0	R/W	float	external analog value, interface 4
0x12E2	R/W	float	external analog value, interface 5
0x12E4	R/W	float	external analog value, interface 6
0x12E6	R/W	float	external analog value, interface 7
0x12E8	R/W	float	external analog value, interface 8
0x12EA	R/W	float	external analog value, interface 9
0x12EC	R/W	float	external analog value, interface 10
0x12EE	R/W	float	external analog value, interface 11
0x12F0	R/W	float	external analog value, interface 12
0x12F2	R/W	float	external analog value, interface 13
0x12F4	R/W	float	external analog value, interface 14

## 7 Address tables

Address	Access	Data type	Signal designation
0x12F6	R/W	float	external analog value, interface 15
0x12F8	R/W	float	external analog value, interface 16
0x12FA	R/W	float	external analog value, interface 17
0x12FC	R/W	float	external analog value, interface 18
0x12FE	R/W	float	external analog value, interface 19
0x1300	R/W	float	external analog value, interface 20
0x1302	R/W	float	external analog value, interface 21
0x1304	R/W	float	external analog value, interface 22
0x1306	R/W	float	external analog value, interface 23
0x1308	R/W	float	external analog value, interface 24
0x130A	R	bool	external analog alarm 1, channel 1
0x130B	R	bool	external analog alarm 1, channel 2
0x130C	R	bool	external analog alarm 1, channel 3
0x130D	R	bool	external analog alarm 1, channel 4
0x130E	R	bool	external analog alarm 1, channel 5
0x130F	R	bool	external analog alarm 1, channel 6
0x1310	R	bool	external analog alarm 1, channel 7
0x1311	R	bool	external analog alarm 1, channel 8
0x1312	R	bool	external analog alarm 1, channel 9
0x1313	R	bool	external analog alarm 1, channel 10
0x1314	R	bool	external analog alarm 1, channel 11
0x1315	R	bool	external analog alarm 1, channel 12
0x1316	R	bool	external analog alarm 1, channel 13
0x1317	R	bool	external analog alarm 1, channel 14
0x1318	R	bool	external analog alarm 1, channel 15
0x1319	R	bool	external analog alarm 1, channel 16
0x131A	R	bool	external analog alarm 1, channel 17
0x131B	R	bool	external analog alarm 1, channel 18
0x131C	R	bool	external analog alarm 1, channel 19
0x131D	R	bool	external analog alarm 1, channel 20
0x131E	R	bool	external analog alarm 1, channel 21
0x131F	R	bool	external analog alarm 1, channel 22
0x1320	R	bool	external analog alarm 1, channel 23
0x1321	R	bool	external analog alarm 1, channel 24
0x1322	R	bool	external analog alarm 2, channel 1
0x1323	R	bool	external analog alarm 2, channel 2
0x1324	R	bool	external analog alarm 2, channel 3
0x1325	R	bool	external analog alarm 2, channel 4
0x1326	R	bool	external analog alarm 2, channel 5
0x1327	R	bool	external analog alarm 2, channel 6
0x1328	R	bool	external analog alarm 2, channel 7
0x1329	R	bool	external analog alarm 2, channel 8
0x132A	R	bool	external analog alarm 2, channel 9
0x132B	R	bool	external analog alarm 2, channel 10
0x132C	R	bool	external analog alarm 2, channel 11
0x132D	R	bool	external analog alarm 2, channel 12

## 7 Address tables

Address	Access	Data type	Signal designation
0x132E	R	bool	external analog alarm 2, channel 13
0x132F	R	bool	external analog alarm 2, channel 14
0x1330	R	bool	external analog alarm 2, channel 15
0x1331	R	bool	external analog alarm 2, channel 16
0x1332	R	bool	external analog alarm 2, channel 17
0x1333	R	bool	external analog alarm 2, channel 18
0x1334	R	bool	external analog alarm 2, channel 19
0x1335	R	bool	external analog alarm 2, channel 20
0x1336	R	bool	external analog alarm 2, channel 21
0x1337	R	bool	external analog alarm 2, channel 22
0x1338	R	bool	external analog alarm 2, channel 23
0x1339	R	bool	external analog alarm 2, channel 24
0x133A	R	bool	binary inputs/outputs, status 1
0x133B	R	bool	binary inputs/outputs, status 2
0x133C	R	bool	binary inputs/outputs, status 3
0x133D	R	bool	binary inputs/outputs, status 4
0x133E	R	bool	binary inputs/outputs, status 5
0x133F	R	bool	binary inputs/outputs, status 6
0x1340	R	bool	binary inputs/outputs, status 7
0x1341	R	bool	binary inputs/outputs, status 8
0x1342	R	bool	binary inputs/outputs, status 9
0x1343	R	bool	binary inputs/outputs, status 10
0x1344	R	bool	binary inputs/outputs, status 11
0x1345	R	bool	binary inputs/outputs, status 12
0x1346	R	bool	binary inputs/outputs, status 13
0x1347	R	bool	binary inputs/outputs, status 14
0x1348	R	bool	binary inputs/outputs, status 15
0x1349	R	bool	binary inputs/outputs, status 16
0x134A	R	bool	binary inputs/outputs, status 17
0x134B	R	bool	binary inputs/outputs, status 18
0x134C	R	bool	binary inputs/outputs, status 19
0x134D	R	bool	binary inputs/outputs, status 20
0x134E	R	bool	binary inputs/outputs, status 21
0x134F	R	bool	binary inputs/outputs, status 22
0x1350	R	bool	binary inputs/outputs, status 23
0x1351	R	bool	binary inputs/outputs, status 24
0x1352	R	bool	binary inputs/outputs, alarm 1
0x1353	R	bool	binary inputs/outputs, alarm 2
0x1354	R	bool	binary inputs/outputs, alarm 3
0x1355	R	bool	binary inputs/outputs, alarm 4
0x1356	R	bool	binary inputs/outputs, alarm 5
0x1357	R	bool	binary inputs/outputs, alarm 6
0x1358	R	bool	binary inputs/outputs, alarm 7
0x1359	R	bool	binary inputs/outputs, alarm 8
0x135A	R	bool	binary inputs/outputs, alarm 9
0x135B	R	bool	binary inputs/outputs, alarm 10

## 7 Address tables

Address	Access	Data type	Signal designation
0x135C	R	bool	binary inputs/outputs, alarm 11
0x135D	R	bool	binary inputs/outputs, alarm 12
0x135E	R	bool	binary inputs/outputs, alarm 13
0x135F	R	bool	binary inputs/outputs, alarm 14
0x1360	R	bool	binary inputs/outputs, alarm 15
0x1361	R	bool	binary inputs/outputs, alarm 16
0x1362	R	bool	binary inputs/outputs, alarm 17
0x1363	R	bool	binary inputs/outputs, alarm 18
0x1364	R	bool	binary inputs/outputs, alarm 19
0x1365	R	bool	binary inputs/outputs, alarm 20
0x1366	R	bool	binary inputs/outputs, alarm 21
0x1367	R	bool	binary inputs/outputs, alarm 22
0x1368	R	bool	binary inputs/outputs, alarm 23
0x1369	R	bool	binary inputs/outputs, alarm 24
0x136A	R/W	char 64	external batch text 1
0x138A	R/W	char 64	external batch text 2
0x13AA	R/W	char 64	external batch text 3
0x13CA	R/W	char 64	external batch text 4
0x13EA	R/W	char 64	external batch text 5
0x140A	R/W	char 64	external batch text 6
0x142A	R/W	char 64	external batch text 7
0x144A	R/W	char 64	external batch text 8
0x146A	R/W	char 64	external batch text 9
0x148A	R/W	char 94	external event text, group 1
0x14B9	R/W	char 94	external event text, group 2
0x14E8	R/W	char 94	external event text, group 3
0x1517	R/W	char 94	external event text, group 4
0x1546	R/W	char 94	external event text, group 5
0x1575	R/W	char 94	external event text, group 6
0x15A4	R/W	char 94	external event text, group 7
0x15D3	R/W	char 94	external event text, group 8
0x1602	R/W	char 94	external event text, group 9
0x1631	R	bool	relay output 1
0x1632	R	bool	relay output 2
0x1633	R	bool	relay output 3
0x1634	R	bool	relay output 4
0x1635	R	bool	relay output 5
0x1636	R	bool	relay output 6
0x1637	R	bool	relay output 7
0x1638	R/W	bool	external binary input, status 1
0x1639	R/W	bool	external binary input, status 2
0x163A	R/W	bool	external binary input, status 3
0x163B	R/W	bool	external binary input, status 4
0x163C	R/W	bool	external binary input, status 5
0x163D	R/W	bool	external binary input, status 6
0x163E	R/W	bool	external binary input, status 7

## 7 Address tables

Address	Access	Data type	Signal designation
0x163F	R/W	bool	external binary input, status 8
0x1640	R/W	bool	external binary input, status 9
0x1641	R/W	bool	external binary input, status 10
0x1642	R/W	bool	external binary input, status 11
0x1643	R/W	bool	external binary input, status 12
0x1644	R/W	bool	external binary input, status 13
0x1645	R/W	bool	external binary input, status 14
0x1646	R/W	bool	external binary input, status 15
0x1647	R/W	bool	external binary input, status 16
0x1648	R/W	bool	external binary input, status 17
0x1649	R/W	bool	external binary input, status 18
0x164A	R/W	bool	external binary input, status 19
0x164B	R/W	bool	external binary input, status 20
0x164C	R/W	bool	external binary input, status 21
0x164D	R/W	bool	external binary input, status 22
0x164E	R/W	bool	external binary input, status 23
0x164F	R/W	bool	external binary input, status 24
0x1650	R	bool	external binary input, alarm 1
0x1651	R	bool	external binary input, alarm 2
0x1652	R	bool	external binary input, alarm 3
0x1653	R	bool	external binary input, alarm 4
0x1654	R	bool	external binary input, alarm 5
0x1655	R	bool	external binary input, alarm 6
0x1656	R	bool	external binary input, alarm 7
0x1657	R	bool	external binary input, alarm 8
0x1658	R	bool	external binary input, alarm 9
0x1659	R	bool	external binary input, alarm 10
0x165A	R	bool	external binary input, alarm 11
0x165B	R	bool	external binary input, alarm 12
0x165C	R	bool	external binary input, alarm 13
0x165D	R	bool	external binary input, alarm 14
0x165E	R	bool	external binary input, alarm 15
0x165F	R	bool	external binary input, alarm 16
0x1660	R	bool	external binary input, alarm 17
0x1661	R	bool	external binary input, alarm 18
0x1662	R	bool	external binary input, alarm 19
0x1663	R	bool	external binary input, alarm 20
0x1664	R	bool	external binary input, alarm 21
0x1665	R	bool	external binary input, alarm 22
0x1666	R	bool	external binary input, alarm 23
0x1667	R	bool	external binary input, alarm 24
0x1668	R	float	math result 1
0x166A	R	float	math result 2
0x166C	R	float	math result 3
0x166E	R	float	math result 4
0x1670	R	float	math result 5

## 7 Address tables

Address	Access	Data type	Signal designation
0x1672	R	float	math result 6
0x1674	R	float	math result 7
0x1676	R	float	math result 8
0x1678	R	float	math result 9
0x167A	R	bool	math alarm 1, 1
0x167B	R	bool	math alarm 1, 2
0x167C	R	bool	math alarm 1, 3
0x167D	R	bool	math alarm 1, 4
0x167E	R	bool	math alarm 1, 5
0x167F	R	bool	math alarm 1, 6
0x1680	R	bool	math alarm 1, 7
0x1681	R	bool	math alarm 1, 8
0x1682	R	bool	math alarm 1, 9
0x1683	R	bool	math alarm 2, 1
0x1684	R	bool	math alarm 2, 2
0x1685	R	bool	math alarm 2, 3
0x1686	R	bool	math alarm 2, 4
0x1687	R	bool	math alarm 2, 5
0x1688	R	bool	math alarm 2, 6
0x1689	R	bool	math alarm 2, 7
0x168A	R	bool	math alarm 2, 8
0x168B	R	bool	math alarm 2, 9
0x168C	R	bool	logic result 1
0x168D	R	bool	logic result 2
0x168E	R	bool	logic result 3
0x168F	R	bool	logic result 4
0x1690	R	bool	logic result 5
0x1691	R	bool	logic result 6
0x1692	R	bool	logic result 7
0x1693	R	bool	logic result 8
0x1694	R	bool	logic result 9
0x1695	R	bool	logic alarm 1
0x1696	R	bool	logic alarm 2
0x1697	R	bool	logic alarm 3
0x1698	R	bool	logic alarm 4
0x1699	R	bool	logic alarm 5
0x169A	R	bool	logic alarm 6
0x169B	R	bool	logic alarm 7
0x169C	R	bool	logic alarm 8
0x169D	R	bool	logic alarm 9
0x169E	R	bool	limit comparator status 1
0x169F	R	bool	limit comparator status 2
0x16A0	R	bool	limit comparator status 3
0x16A1	R	bool	limit comparator status 4
0x16A2	R	bool	limit comparator status 5

## 7 Address tables

Address	Access	Data type	Signal designation
0x16A3	R	bool	limit comparator status 6
0x16A4	R	bool	limit comparator status 7
0x16A5	R	bool	limit comparator status 8
0x16A6	R	bool	limit comparator status 9
0x16A7	R	bool	limit comparator alarm 1
0x16A8	R	bool	limit comparator alarm 2
0x16A9	R	bool	limit comparator alarm 3
0x16AA	R	bool	limit comparator alarm 4
0x16AB	R	bool	limit comparator alarm 5
0x16AC	R	bool	limit comparator alarm 6
0x16AD	R	bool	limit comparator alarm 7
0x16AE	R	bool	limit comparator alarm 8
0x16AF	R	bool	limit comparator alarm 9
0x16B0	R	bool	counter alarm 1, 1
0x16B1	R	bool	counter alarm 1, 2
0x16B2	R	bool	counter alarm 1, 3
0x16B3	R	bool	counter alarm 1, 4
0x16B4	R	bool	counter alarm 1, 5
0x16B5	R	bool	counter alarm 1, 6
0x16B6	R	bool	counter alarm 1, 7
0x16B7	R	bool	counter alarm 1, 8
0x16B8	R	bool	counter alarm 1, 9
0x16B9	R	bool	counter alarm 1, 10
0x16BA	R	bool	counter alarm 1, 11
0x16BB	R	bool	counter alarm 1, 12
0x16BC	R	bool	counter alarm 1, 13
0x16BD	R	bool	counter alarm 1, 14
0x16BE	R	bool	counter alarm 1, 15
0x16BF	R	bool	counter alarm 1, 16
0x16C0	R	bool	counter alarm 1, 17
0x16C1	R	bool	counter alarm 1, 18
0x16C2	R	bool	counter alarm 1, 19
0x16C3	R	bool	counter alarm 1, 20
0x16C4	R	bool	counter alarm 1, 21
0x16C5	R	bool	counter alarm 1, 22
0x16C6	R	bool	counter alarm 1, 23
0x16C7	R	bool	counter alarm 1, 24
0x16C8	R	bool	counter alarm 1, 25
0x16C9	R	bool	counter alarm 1, 26
0x16CA	R	bool	counter alarm 1, 27
0x16CB	R	bool	counter alarm 2, 1
0x16CC	R	bool	counter alarm 2, 2
0x16CD	R	bool	counter alarm 2, 3
0x16CE	R	bool	counter alarm 2, 4
0x16CF	R	bool	counter alarm 2, 5
0x16D0	R	bool	counter alarm 2, 6

## 7 Address tables

---

Address	Access	Data type	Signal designation
0x16D1	R	bool	counter alarm 2, 7
0x16D2	R	bool	counter alarm 2, 8
0x16D3	R	bool	counter alarm 2, 9
0x16D4	R	bool	counter alarm 2, 10
0x16D5	R	bool	counter alarm 2, 11
0x16D6	R	bool	counter alarm 2, 12
0x16D7	R	bool	counter alarm 2, 13
0x16D8	R	bool	counter alarm 2, 14
0x16D9	R	bool	counter alarm 2, 15
0x16DA	R	bool	counter alarm 2, 16
0x16DB	R	bool	counter alarm 2, 17
0x16DC	R	bool	counter alarm 2, 18
0x16DD	R	bool	counter alarm 2, 19
0x16DE	R	bool	counter alarm 2, 20
0x16DF	R	bool	counter alarm 2, 21
0x16E0	R	bool	counter alarm 2, 22
0x16E1	R	bool	counter alarm 2, 23
0x16E2	R	bool	counter alarm 2, 24
0x16E3	R	bool	counter alarm 2, 25
0x16E4	R	bool	counter alarm 2, 26
0x16E5	R	bool	counter alarm 2, 27
0x17B0	R	bool	combination alarm
0x17B1	R	byte	Ethernet IP address, byte 1
0x17B2	R	byte	Ethernet IP address, byte 2
0x17B3	R	byte	Ethernet IP address, byte 3
0x17B4	R	byte	Ethernet IP address, byte 4
0x9000	R/W	char 1204	recipe for active batch 0
0x9400	R/W	char 1204	recipe for active batch 1
0x9800	R/W	char 1204	recipe for active batch 2

### A

Address tables *43*  
Areas of application *7*

### B

Bar code *12, 37*  
Bar code reader *10*  
Baud rate *12, 16*  
Browser *38*

### C

Checksum (CRC16) *24*  
Configuration via keypad *12*  
Connecting cable *11*  
Connection diagram *9–10*

### D

Data format *15*  
Data structure *17*  
Device address *12, 18*  
Device data *43*  
Double values *23*

### E

E-mail *33, 35, 40, 42*  
E-mail dispatch via modem and Ethernet *30*  
Error handling *25*  
Errors *25*  
Ethernet *10, 13–14*

### F

Float values *22*  
Function summary *18*

### H

HTTP *38*

### I

Integer values *22*  
Interface type *7, 12*

### M

Min. response time *12, 17*  
Modbus *15*  
Modbus broadcast address *18*

## 8 Index

---

Modbus double format 23  
Modbus error codes 25  
Modbus float format 22  
Modbus master 7, 12  
Modbus slave 7, 12  
Modbus telegram 17  
Modbus-TCP 39  
Modem operation 33

### O

Overrange 26

### P

Parity bit 15  
POP3 40  
Protocol 12

### R

Read command 19  
Relay outputs 25  
RS232 10–11  
RS485 10–11  
RTU 12, 15

### S

SMTP 31, 40  
Stop bit 15  
System requirements 7

### T

Telegram 39  
Terminal assignment 11  
Timing sequence 16

### U

Underrange 26

### W

Write command 20–21





**JUMO GmbH & Co. KG**

Street address:  
Moltkestraße 13 - 31  
36039 Fulda, Germany  
Delivery address:  
Mackenrodtstraße 14  
36039 Fulda, Germany  
Postal address:  
36035 Fulda, Germany  
Phone: +49 661 6003-0  
Fax: +49 661 6003-607  
e-mail: [mail@jumo.net](mailto:mail@jumo.net)  
Internet: [www.jumo.net](http://www.jumo.net)

**JUMO Instrument Co. Ltd.**

JUMO House  
Temple Bank, Riverway  
Harlow, Essex CM20 2TT, UK  
Phone: +44 1279 635533  
Fax: +44 1279 635262  
e-mail: [sales@jumo.co.uk](mailto:sales@jumo.co.uk)  
Internet: [www.jumo.co.uk](http://www.jumo.co.uk)

**JUMO Process Control, Inc.**

8 Technology Boulevard  
Canastota, NY 13032, USA  
Phone: 315-697-JUMO  
1-800-554-JUMO  
Fax: 315-697-5867  
e-mail: [info@jumo.us](mailto:info@jumo.us)  
Internet: [www.jumo.us](http://www.jumo.us)