

Digital Indicator with linearisation and alarm contacts

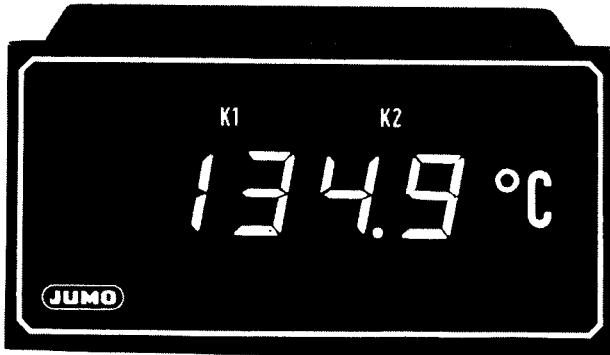

Type PDA.-48m/...

All necessary settings and, where appropriate, alterations by the specialist are described in these Operating Instructions. If, however, any difficulties should arise during start-up please do not carry out any manipulations on the instrument which are not permitted. You could endanger your rights under the instrument warranty. Please contact the nearest office or the main factory.

B 95.1030

8.97 / 00073979

Operating Instructions

M. K. JUCHHEIM GmbH & Co · 36035 Fulda · Germany · Phone (06 61) 60 03-0
Telefax (06 61) 60 03-607 · Telex 4 9701 juf d · email JUMO_de@e-mail.com

ADJUSTMENTS INSIDE THE INSTRUMENT

Opening the instrument

The indicator provides a large number of adjustments. Access to them is obtained by levering the fascia out of the housing with a screwdriver, using the the cut-outs at the bottom left and right.

Indicator with fascia removed:

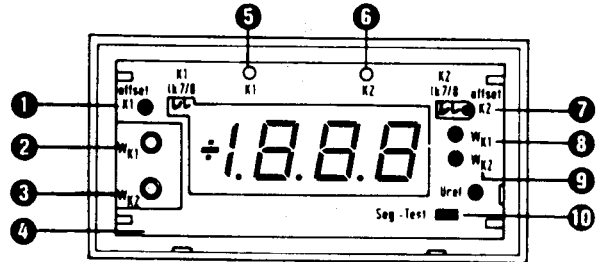

- ① Switching point adjustment K1
- ② Setpoint key W_{K1}
- ③ Setpoint key W_{K2}
- ④ Cover panel
- ⑤ LED for alarm contact K1
- ⑥ LED for alarm contact K2
- ⑦ Switching point adjustment K2
- ⑧ Setpoint adjustment W_{K1}
- ⑨ Setpoint adjustment W_{K2}
- ⑩ Contact for segment test
(on closing with screwdriver
all segments light up)

Indicator with fascia and cover panel removed:

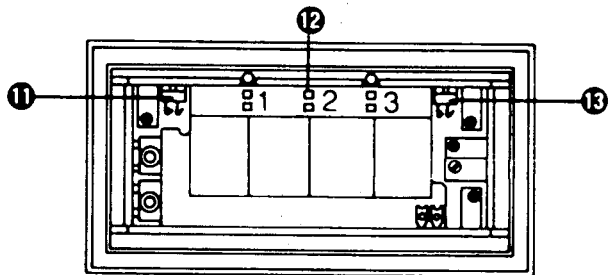

- ⑪ Contact function Ik7/8 for limit comparator K1 (see p. 3)
- ⑫ Links for decimal place selection (see p. 3)
- ⑬ Contact function Ik7/8 for limit comparator K2 (see p. 3)

ADJUSTMENTS INSIDE THE INSTRUMENT

Contact function of the limit comparators

K1	K2	Contact	Function
11	12		lk 7
			lk 8

Selecting decimal place

The appropriate solder link is opened or closed to change the decimal place as shown alongside. The factory setting depends on the order specification.

	1.888
	18.88
	188.8
	1888

After releasing the two countersunk screws in the top and bottom of the housing the chassis can be withdrawn for adjustments on the PDA-48m/um. The input signal can be adjusted (see page 4) after connecting the unit to the mains supply and to a current or voltage source.

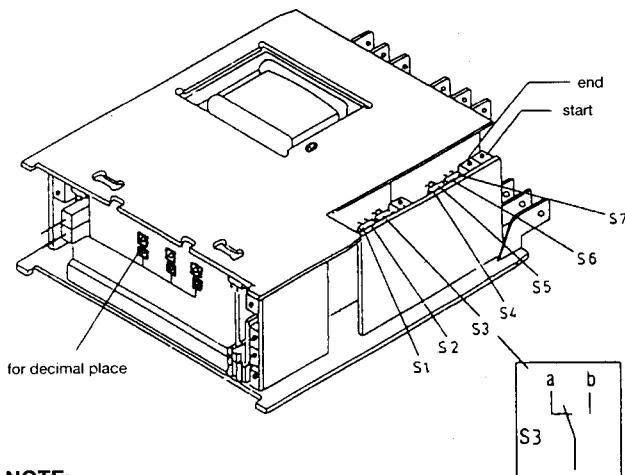

NOTE:
work on live
parts must only be
carried out by a specialist.

ADJUSTMENTS INSIDE THE INSTRUMENT

Setting the display on the PDA.-48m/um

The table below is used to select the input signal with the switches S1 - S3, the range span with switches S4, S5 and the range shift with switches S6 or S7. Fine adjustment of the standard signal is provided by the two spindle trimmers (for start and end).

Input signal	Switch setting		
	S1	S2	S3
0 - 10 V	off	off	a
0 - 20 mA	on	on	a
4 - 20 mA	on	on	b
Range span	S4	S5	
1000 digit	off	off	
2000 digit	on	off	
3000 digit	off	on	
4000 digit	on	on	
Range shift	S6	S7	
-2000 to -1000 digit	off	off	
-1000 to 0 digit	on	off	
0 to 1000 digit	off	on	
1000 to 2000 digit	on	on	

Example:

Setting the input current 0 - 20 mA
Display: -1000 to +1000
Span: 2000 digit
Range shift: -1000 digit

1. Set the input signal to 0-20 mA
switch S1 = on, S2 = on, S3 = a
2. Set the range span to 2000 digit
switch S4 = on, S5 = off
3. Set the range shift to -1000 digit
switch S6 = on, S7 = off
4. Set current source to 0 mA and adjust start of range with spindle trimmer to -1000.
5. Set current source to 20 mA and adjust end of range with spindle trimmer to +1000.
6. Check start and end of range and readjust if necessary.

INFORMATION ON THE INSTRUMENT

Identifying the model

Identify the model using the instrument label, the designation listed below and the extra Codes.

Type designation

PDA.-48m/...	modular digital indicator with output 1 mV/digit	u24	supply output 24 V 40 mA for 2-wire transmitters**
w	for use with resistance thermometers in 3-wire circuit	lk*	2 limit comparators adjustable over the full range
t	for use with thermocouples	lk7	relay de-energised below setpoint
e	for use with linear current transducers	lk8	relay de-energised above setpoint
u	for use with linear voltage transducers		
-48	bezel 96 x 48 mm		

PDA-48m/um	modular digital indicator with process output and range selector for standard signals 0 - 20 mA, 4 - 20 mA or 0 - 10 V
------------	---

* specify in full
** to special order
29 V max. open-circuit voltage (stabilised voltage output available)

Ordering example

PDA t - 48 m / lk78

Digital indicator

for use with thermocouples (specify type and range in full)

bezel 96 x 48 mm

modular construction

limit comparators lk7 and lk8

Standard accessories

2 Mounting brackets to DIN 43 835, Form A
1 Operating Instructions

Extra Codes

w.../wfg	for use with resistance transmitters with 3-wire connection
DC	supply 12 or 24 V d.c.*
AC	supply 24 or 42 V a.c.*
IA...	analogue output
020	0 - 20 mA
420	4 - 20 mA
010	0 - 10 V

* specify in full

INSTALLATION

Insert the instrument from the front into the panel cut-out **1**. Slide the two mounting brackets **2** on to the pegs **3** on the left and right side of the instrument and push them from the back against the panel until they click home. The instrument will operate satisfactorily within the ambient temperature range 0 to 55°C at a relative humidity not exceeding 75%.

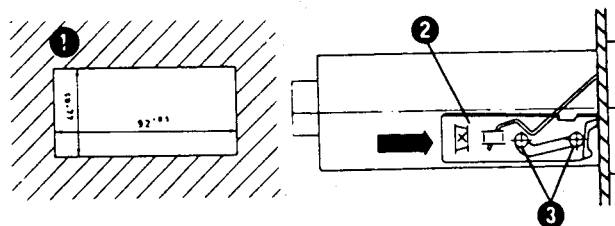

Electrical connection

The electrical connections to the instrument are made with faston connectors to DIN 46 244/A 6.3 x 0.8 mm according to the connection diagram. The appropriate VDE or local regulations have to be observed.

Line balancing and fault indication

- with thermocouples:

No line balancing is required when used with thermocouples. The PDA.-48m/... is fitted with ambient temperature compensation as standard.

The permitted line resistance per line is 50 Ω. The signal circuit is monitored for thermocouple or line break and overrange. Fault indication: 1... display dark

- on resistance thermometers w:

No line balancing is required with equal line resistances (50 Ω max.). Connection via zener barriers is possible.

Fault indication for resistance thermometer or line break: -1... display dark

- on resistance transmitters w.../wfg:

Line balancing conditions as for resistance thermometer w.

Fault indication for transmitter or line short-circuit or break: -1... display dark

- on transducers with standard signal e(u):

Fault indication

- on underrange: -1... display dark

- on overrange: 1... display dark

CONNECTION DIAGRAM

Connection for	Code	Terminals	Diagram
Supply as on rating label Loading 7 VA max.		1 L1 line 1 U on 2 L1 line 2 U a.c. N neutral	L + on L - d.c. 200 mA max.
Thermocouple	t	11 + 12 -	
Current or voltage d.c.	e,u	11 + 12 -	
Current or voltage input through range selector	um	11 + 12 -	
Resistance thermometer in 2-wire circuit	w	11 } resistance thermometer 12 } 13 }	
Resistance thermometer in 3-wire circuit		11 no line balancing 12 for $R_L = 50 \Omega$ max. 13	
Resistance transmitter with 3-wire connection	w.../wfg	11 S = slider no line 12 A = start balancing for 13 E = end $R_L = 50 \Omega$ max.	
Analogue output on range -199.9 +199.9 Pt 100		31 + 10 mV/°C 32 - burden 1 kΩ min.	
Analogue output on range 0 - 600°C Pt 100 or thermocouple input		31 + 1 mV/digit linearised 32 - burden 1 kΩ min.	
Analogue output d.c. current/voltage	IA...	31 + 0-20 mA, burden 750 Ω max. 32 - 4-20 mA, burden 750 Ω max. 0-10 VC, burden 2 kΩ min.	
Display hold		17 + external contact 18 -	
Extra supply output	u24	81 + 24 V 40 mA 82 -	
Limit comparator 1	lk7,8	42 common rating 43 n.o. (closing) 250 V 4 A a.c. 41 n.c. (opening) 24 V 2 A d.c.	
Limit comparator 2	lk7,8	52 common rating 53 n.o. (closing) 250 V 4 A a.c. 51 n.c. (opening) 24 V 2 A d.c.	