

Digital 2-channel
microprocessor
indicator

B 95.1510
Operating Instructions

3.99/00085790

Operating scheme

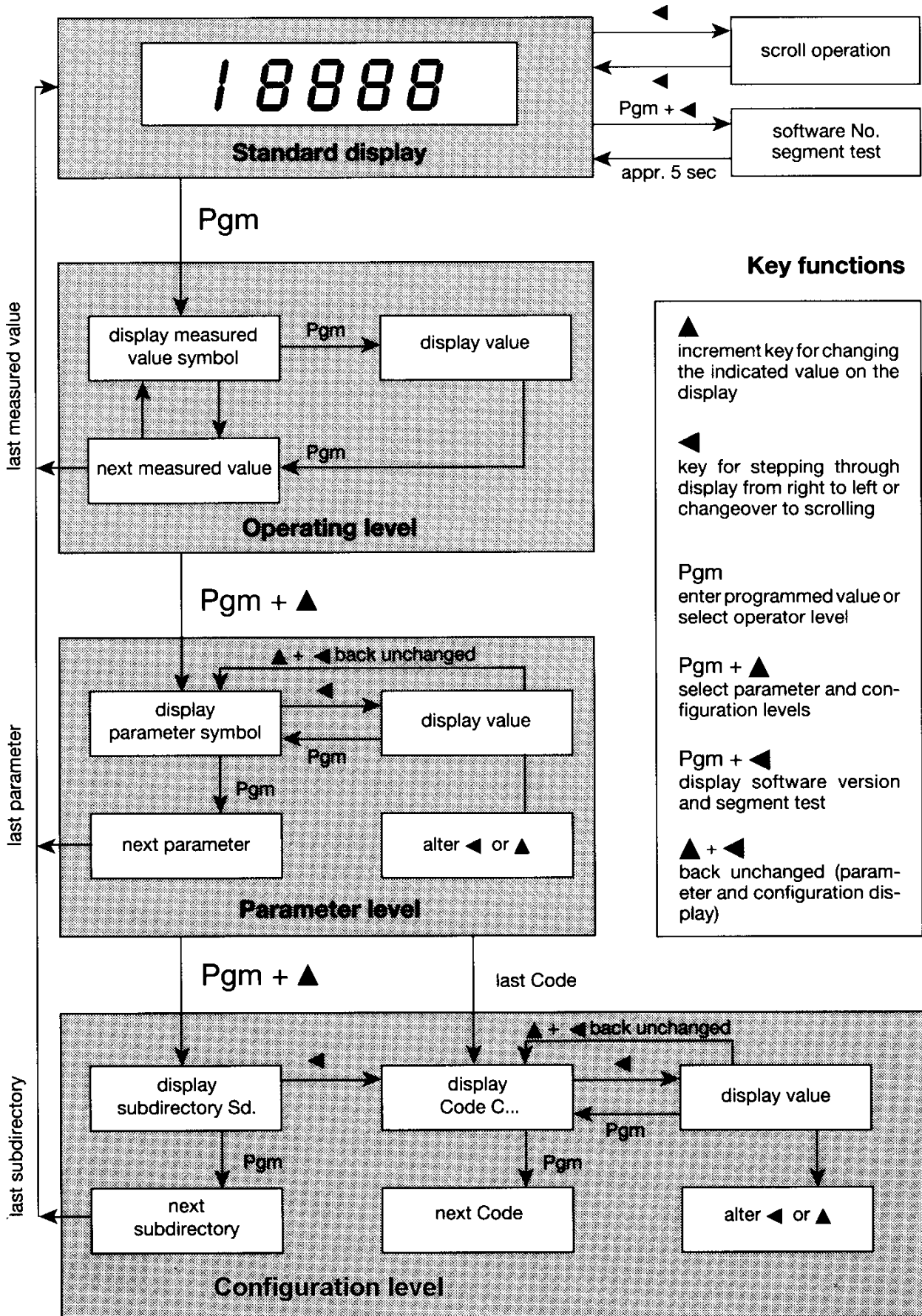

1	Description	3
1.1	Type designation	3
1.2	Technical data	5
1.3	Indications and controls	7
2	Installation	8
2.1	Location and climatic conditions	8
2.2	Mounting in position	8
2.3	Dimensions	8
3	Electrical connection	9
3.1	Connection diagram	9
3.2	Important installation notes	11
4	Operation	12
4.1	Levels and inhibits	12
4.2	Indicated measured value	13
4.3	Table of callable variables	13
5	Parameter level (alarms)	14
5.1	Alarms	14
5.2	Indication and alteration of alarm settings	14
5.3	Limit comparator functions	15
6	Configuration level	17
6.1	Finding subdirectories	17
6.2	Displaying and editing configuration data	17
6.3	Configuration tables	18
7	Action on faults	25
7.1	Error message	25
7.2	Action on supply failure	25
7.3	Action on overrange or underrange	25
8	Adjustments inside the instrument	26
9	Extra functions	28
9.1	Functions of the external contacts	28
9.2	Scroll function (automatic display change)	29
9.3	Humidity measurement	30
9.4	Ratio measurement	30
9.5	Difference measurement	30
9.6	Segment test and call-up of software version	30
10	User-specific settings	31
10.1	Actual value correction	31
10.2	Calibration of indication	32
10.3	Calibration of start and end of output signal	32
10.4	Determining the cold junction temperature for thermocouples	33
10.5	Customer-specific linearisation	34
10.6	Table of settings	36
11	Retrofitting of cards	37

NOTE

All necessary settings and, where appropriate, alterations are described in these Operating Instructions. If, however, any difficulties should arise during start-up, you are asked not to carry out any manipulation on the instrument which is not permitted. – You could endanger your rights under the warranty. Please contact the nearest office or the main factory.

1 Description

Introduction

The indicator MDA2-48, with a size of 96 x 48 mm and a depth of 174 mm behind the panel provides a large number of functions. The two configurable analog inputs permit direct connections to thermocouples or resistance thermometers to DIN IEC, resistance transmitters, or transducers with a standard signal.

The 14 mm high 4½-digit LED display indicates the measured value in normal operation and the input parameters at the function levels PARAMETERS and CONFIGURE.

A large number of standard factory settings can be freely configured over wide ranges. The individual levels can be inhibited to prevent unintended changes. Functions such as key inhibit, storage of reading and maximum or minimum value, auto-tare or blank display, can be activated through two external contacts. Three outputs are available, depending on configuration, to output the actual value (fully isolated) or as a limit comparator for signalling alarms.

The RS232C (V.24) or R422/485 interface (also isolated) has a transfer rate that can be adjusted in the range 150 – 9600 bit/sec. The standard supply voltage is 93 – 263 V AC. Operation on 20 – 47 V AC or 24 – 63 V DC is available to special order. A voltage output 20 V / 22 mA to supply 2-wire transmitters is available as an extra Code.

The instrument conforms to Class KWF of DIN 40 040 and is suitable for ambient temperatures from 0 to 50°C.

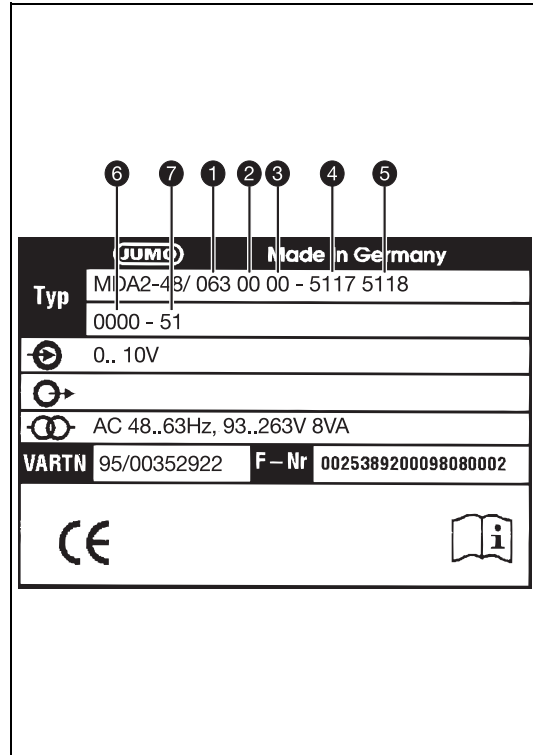

1.1 Type designation

MDA2-48/... , ... , .. - , - , ..
① , **②** , **③ - ④** , **⑤ - ⑥** , **⑦**

① Signal input 1

Resistance thermometers in 3-wire circuit

Pt 100	001
Pt 500	002
Resistance transmitters (specify start and end of range in full)	021

Thermocouples

Cu-Con	T	039
Fe-Con	J	040
Cu-Con	U	041
Fe-Con	L	042
NiCr-Ni	K	043
Pt10Rh-Pt	S	044
Pt13Rh-Pt	R	045
Pt30Rh-Pt6Rh	B	046
MoRe5-MoRe41		047

Temperature compensation internal or external with Pt 100 or cold junction thermostat.

Linearised transducers

0 – 1 mA	051
0 – 20 mA	052
4 – 20 mA	053
0 – 50 mV	061
0 – 1 V	062
0 – 10 V	063

Non-linearised transducers

0 – 1 mA (specify range)	1 .. **
0 – 20 mA (specify range)	2 .. **
4 – 20 mA (specify range)	3 .. **
0 – 50 mV (specify range)	4 .. **
0 – 1 V (specify range)	5 .. **
0 – 10 V (specify range)	6 .. **
Linearisation to customer's values, max 40 points, input signal as above	. 99

** instead of the two dots, enter the last two numbers of the thermocouple code:
 e.g. 241 = input 0 – 20 mA, 41 means linearisation for Cu-Con U

1 Description

② Signal input 2

not used	00
Difference input (transducer as input 1)	01
Display of a second measurement (transducer as input 1)	02
Cold junction temperature (Pt 100 in 3-wire circuit)	03
Ratio input, transducers 0/4 – 20 mA, 0 – 10 V resistance transmitters (transducer as input 1)	05
Humidity input (psychrometric) (both transducers Pt 100)	06

③ 2 logic control inputs

(First function on contact 1, second function on contact 2)	
not used	00
Key inhibit + blank display	14
Auto-tare + reset	23
Measurement store + reset	56

④, ⑤ Output 1, 2

Functions of output	
not used	0000
Actual value output channel 1	8...
Actual value output channel 2	2...

Output signal (specify range)	
0 – 20 mA	.400
4 – 20 mA	.500
–20 / 0 / +20 mA	.600
0 – 10 V	.700
–10 / 0 / +10 V	.800

Limit comparator output signal	
Relay	51 ..
0/5 V, $R_i = 250 \Omega$	52 ..
Semiconductor relay 1 A	53 ..

Function	
not used	.. 00
lk1 referred to input 1	.. 11
lk2 referred to input 1	.. 12
lk3 referred to input 1	.. 13
lk4 referred to input 1	.. 14
lk5 referred to input 1	.. 15
lk6 referred to input 1	.. 16
lk7 referred to input 1	.. 17
lk8 referred to input 1	.. 18
lk7 referred to input 2	.. 27

lk8 referred to input 2 .. 28

⑥ Output 3

Function	
not used	0000
Auxiliary supply for 2-wire transmitter 20 V / 22 mA	0079

Limit comparator output signal	
Relay	51 ..
0/5 V, $R_i = 250 \Omega$	52 ..
Semiconductor relay 1 A	53 ..

Function	
no function	.. 00
lk7 referred to input 1	.. 17
lk8 referred to input 1	.. 18
lk7 referred to input 2	.. 27
lk8 referred to input 2	.. 28

⑦ Extra Codes

Interface RS232C (V.24)	51
Interface RS422/485	52

1.2 Technical data

Indicator for use with resistance thermometers

Input Pt 100, Pt 500 in 3-wire circuit

Indication range -200.0 to +850.0°C
(°C or °F)

Line balance not required with 3-wire circuit. Line balancing is required when using a resistance thermometer in 2-wire circuit. Line balancing can take place either at the configuration level or by using an external line-balancing resistor.

$$R_{\text{balance}} = R_{\text{line}}$$

Indicator for use with thermocouples

Input Cu-Con U, Fe-Con L, Cu-Con T, Fe-Con J, NiCr-Ni K, Pt10Rh-Pt S, Pt13Rh-Pt R, Pt30Rh-PtRh B or MoRe5-MoRe41 to IEC or ISA

Indication ranges (°C or °F)	Cu-Con U	-200 to + 600°C	Fe-Con L	-200 to +1000°C
	Cu-Con T	-200 to + 400°C	Fe-Con J	-200 to + 900°C
	NiCr-Ni K	-200 to +1400°C	Pt10Rh-Pt S	0 to +1800°C
	Pt13Rh-Pt R	0 to +1800°C	Pt30Rh-PtRh B	-200 to +1820°C
	MoRe5-MoRe41	0 to +2000°C		

Temperature compensation can be configured internally or externally or with an external cold junction.

Indicator for use with linearised transducers with standard signal (current or voltage)

Input	0 – 1 mA	$R_i = 50 \Omega$	0 – 50 mV	R_i more than 100 k Ω
	0/4 – 20 mA	$R_i = 2.5 \Omega$	0 – 1 V	$R_i = 50 \text{ k}\Omega$
			0 – 10 V	$R_i = 500 \text{ k}\Omega$

Indication range can be freely configured

Indicator for use with non-linearised transducers with standard signal

Input as for linearised transducers with standard signal

Indication range value assignment and linearisation can be configured.

Indicator for use with resistance transmitters

Input range: min. 0 – 30 Ω , max. 0 – 10 k Ω

Indication can be configured within the range -19999 to +1999 digit.

General data

Outputs 3 configurable outputs are available

- | | | | |
|---|----|--------------------------------------|---|
| Output 1,
Output 2,
Output 3 | 1. | Relay outputs with floating contacts | |
| | | Rating: | 660 W 3A at 220 V 50 Hz resistive load |
| | | Contact life: | approx. 10^6 operations at rated load |
| | 2. | Logic output | 0/5 V or 0/20 mA $R_i = 250 \Omega$ |
| | 3. | Semiconductor relay output | 1 A at 220 V 50 Hz, p.f. 0.7 min |

- | | | | |
|---------------------------------------|-----------------|--------------------------------|-------------------|
| Output 1 and
Output 2 only | 4. | Actual value output (isolated) | |
| | | switch-selected | burden resistor |
| | | 0 – 20 mA | 500 Ω max. |
| | | 4 – 20 mA | 500 Ω max. |
| | | -20 / 0 / +20 mA | 500 Ω max. |
| | | 0 – 10 V | 500 Ω min. |
| | -10 / 0 / +10 V | 500 Ω min. | |

1 Description

Output 3 only	5. Voltage output for 2-wire transmitter 20 V / 22 mA, short-circuit proof, isolated.			
D/A converter	Resolution 13 bit			
Output signal accuracy	0.25 % or better, referred to signal span.			
A/D converter	Resolution 16 bit			
Sampling rate	Channel 1	400 msec	Channel 2	800 msec

Indicator accuracy

Ambient temperature error

when used with resistance thermometers and resistance transmitters

0.05% or better

0.01%/10°C or less

when used with thermocouples within their working range

0.25% or better

0.05%/10°C or less

when used with linearised transducers with standard signal

0.15% or better

0.1%/10°C or less

* These values are based on the particular span, and include the linearisation tolerances.

Signal circuit monitor (Sensor break or short-circuit) The outputs move to a predefined status.

Isolation

between inputs	$\Delta U_{\max} = 5 \text{ V}$
outputs to inputs	
– for actual value output	$\Delta U_{\max} = 50 \text{ V}$
– for interface	$\Delta U_{\max} = 50 \text{ V}$

Data storage EEPROM

Supply normally: 93 – 263 V AC 48 – 63 Hz
to special order: 20 – 43 V AC 48 – 63 Hz 24 – 63 V DC

Power consumption 8 VA approx.

Electrical connection through faston tags to DIN 46244/A, 4.8 x 0.8 mm

Ambient temperature Permitted range is 0 to 50°C

Storage temperature Permitted range is –40 to +70°C

Climatic conditions Class KWF to DIN 40040, relative humidity not exceeding 75 % annual mean, no condensation.

Case Extruded aluminium sections, black anodized, with plug-in chassis.

Protection to DIN 40050, front IP54, rear IP20

Operating position unrestricted

Interfaces RS232C (V.24) or RS422/485 (isolated from the remaining electronics)
Instrument addresses can be configured on RS422/485.
Operating mode: communication mode.

Standard accessories Operating instructions
Mounting brackets

1.3 Indications and controls

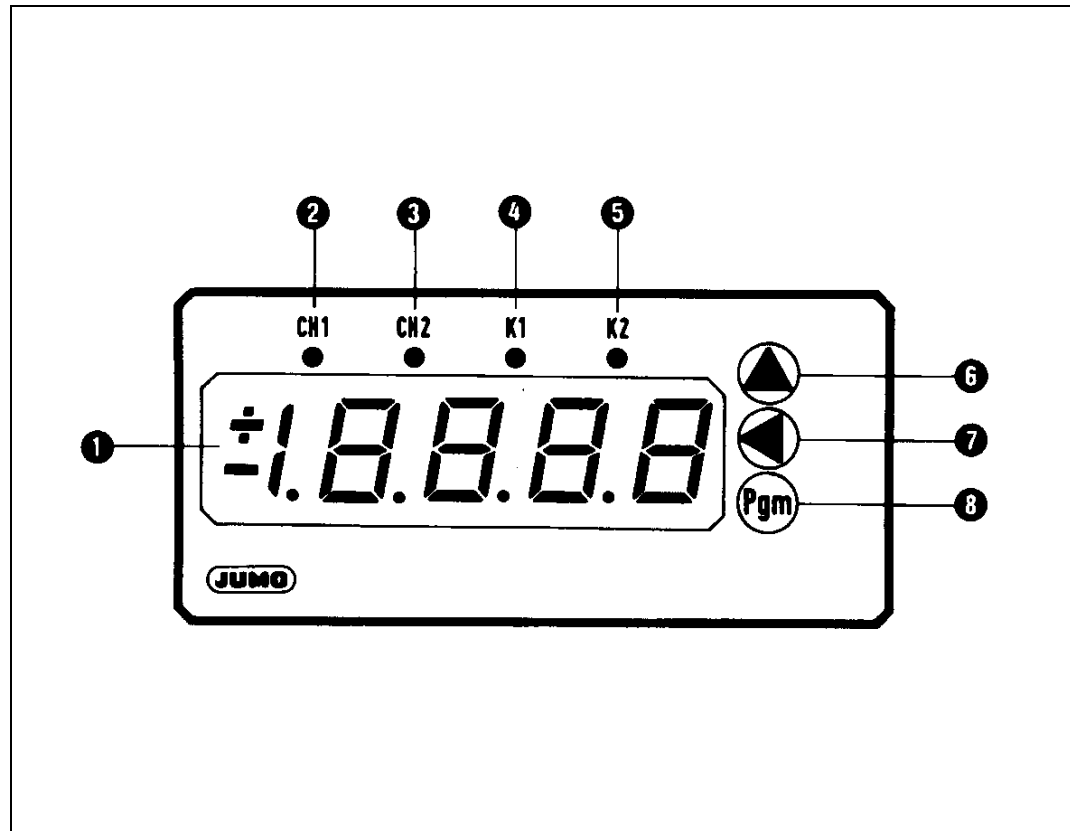

- | | | | |
|---|---|---|---|
| ❶ | 4 1/2-digit numerical LED display
14 mm high | ❹ | Output signal indication
of limit comparator 1 |
| ❷ | Channel indication
Input 1 | ❺ | Output signal indication
of limit comparator 2 |
| ❸ | Channel indication
Input 2 | ❻ | Increment key for changing
a digit during programming |
| | | ❼ | Digit key for selecting
the digit to be changed
during programming |
| | | ❽ | Programming key for
selecting the individual
levels or subdirectories
(in conjunction with
the ▲ and ▼ keys)
and storing the inputs |

2 Installation

2.1 Location and climatic conditions

The instrument location should be as free from vibrations as possible. Electromagnetic fields, caused, for instance, by motors, transformers etc., should be avoided. The ambient temperature at the instrument location may be between 0 and 50°C, at a relative humidity not exceeding 75%. An aggressive atmosphere or fumes reduce the life of the instrument.

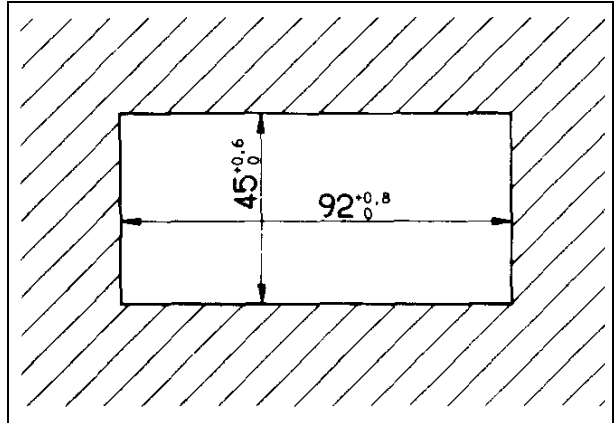

2.2 Mounting in position

The indicator is inserted from the front into the panel cut-out. Behind the panel, the mounting brackets are hooked into the recesses at the sides of the case. The flat sides of the brackets must be against the case. Place the brackets against the back of the panel and tighten them evenly with a screwdriver.

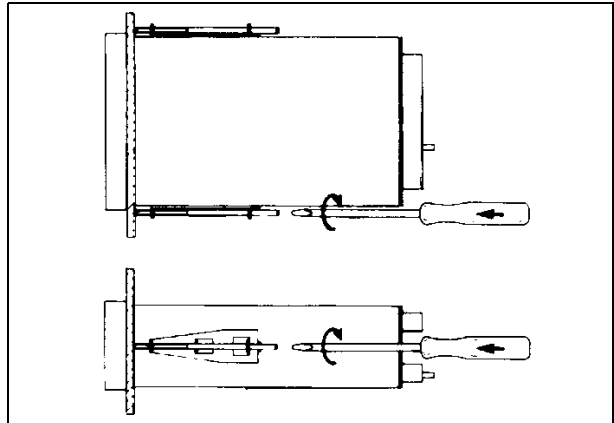

2.3 Dimensions

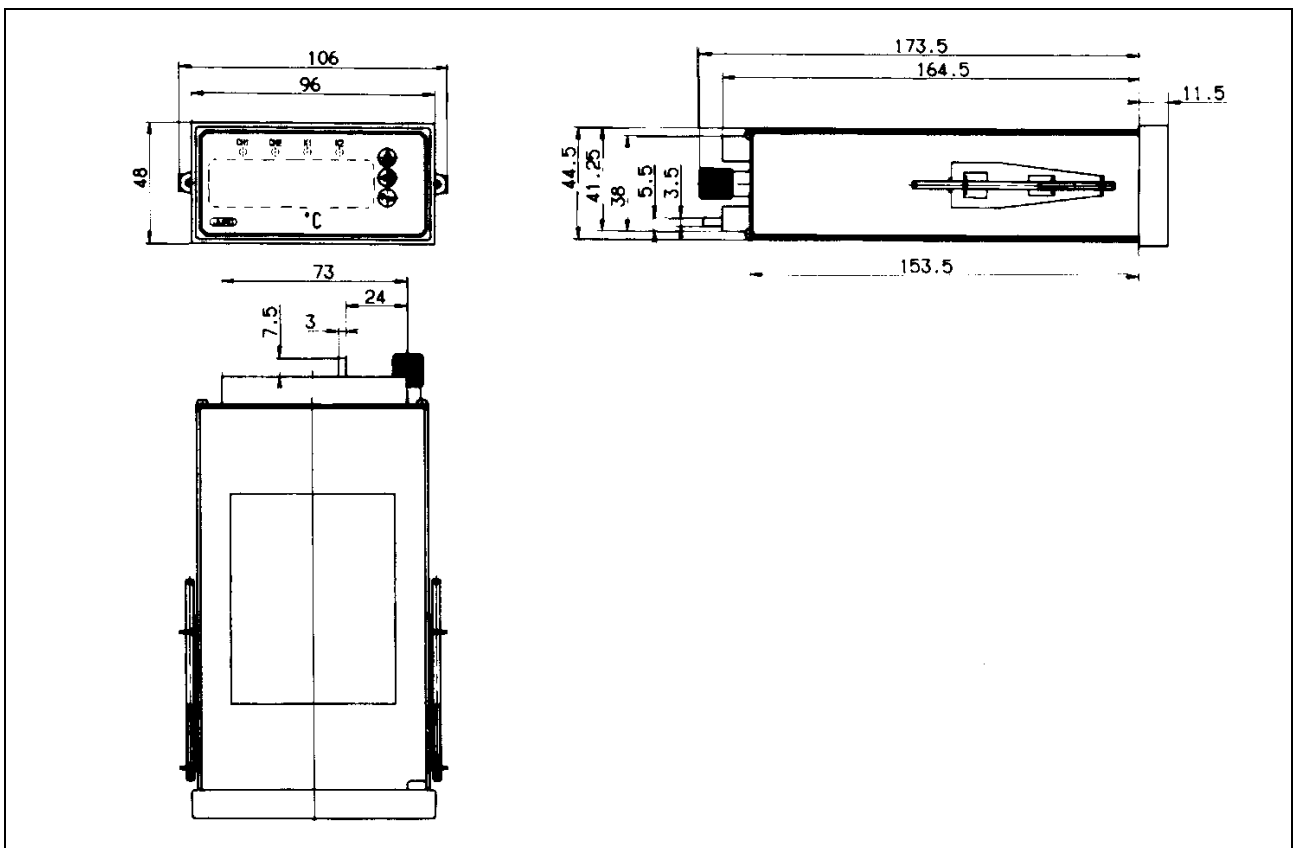

3 Electrical connection

3.1 Connection diagram

The electrical connections have to be made according to the connection scheme below. The choice of cable and the connection of the supply line must conform to the requirements of VDE 0100 "Regulations on the Installation of Power Circuits with nominal voltages below 1000 V" or the appropriate local regulations.

The diagram on the right shows the rear view, with faston connectors.

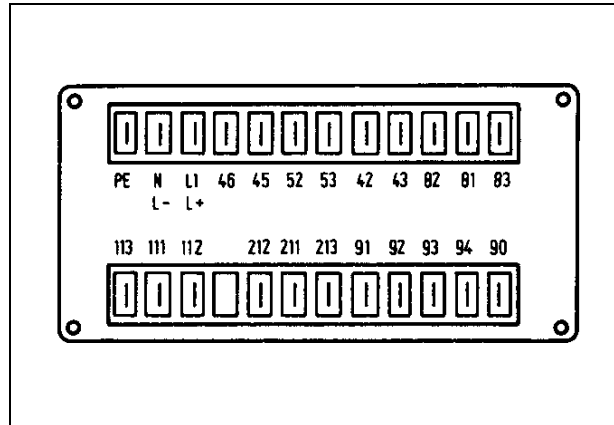

Connection for	Terminals					Diagram
	Output No.	Relay output *	Actual value output	SCR output **	Logic control output 0/5 V $R_i=250\Omega$	
Relay, semiconductor relay, logic outputs, or actual value output	1	42 n.o. (make) 43 common	42 - 43 +	42 43	42 - 43 +	
	2	52 n.o. (make) 53 common	52 - 53 +	52 53	52 - 53 +	
Switching output or supply for 2-wire transmitter	3	45 common 46 n.o. (make) or 20 V / 22 mA voltage supply		45 46	45 + 46 -	
Supply as on label	AC / DC	L1 line N neutral PE ground	AC	L+ L-	DC	
Signal input	Terminals					
Thermocouple	Input		+	-		
	1	2				
Resistance thermometer in 3-wire circuit	111 112 113	211 212 213				
Resistance thermometer in 2-wire circuit	111 112 113	211 212 213				
Standard signal current/voltage	111 112	211 212	+	-		
Resistance transmitter with 3-wire connection	112 111 113	212 211 213	S = slider E = end A = start			

* Contact protection circuit 22 nF 56 Ω

** Varistor protection circuit 300 V

3 Electrical connection

Connection for	Terminals		
External contact 1	81 82		floating contact
External contact 2	83 82		floating contact
Serial interface RS232C (V.24)	RXD	91	Received data (receiving line)
	TXD	93	Transmitted data (transmitting line)
	CTS	92	Clear to send (ready to send)
	RTS	94	Request to send (switch on transmitter)
	GND	90	Signal ground
Serial interface RS422	RXD	91 + 92 -	Received data (receiving pair)
	TXD	93 + 94 -	Transmitted data (transmitting pair)
	GND	90	Signal ground
Serial interface RS485	RXD / TXD	93 + 94 -	Transmitted/received data (transmitting/receiving pair)
	GND	90	Signal ground

3 Electrical connection

3.2 Important installation notes

- * Work inside the instrument must only be carried out by specialist personnel and to the extent indicated. This also applies to the electrical connection.
- * Isolate the instrument from the supply on both poles if there is a possibility of touching live parts during the work. The chassis is automatically isolated from the supply when it is pulled out.
- * A built-in current limiting resistor interrupts the supply circuit in the event of a short-circuit. The external fuse of the supply should not be rated higher than 1 A (slow). In order to prevent welding of the output-relay contacts in the event of an external short-circuit in the load circuit, this must be fused for the maximum relay current (3 A). Fuse the semiconductor relay circuit at 1 A.
- * There should be no magnetic or electric fields in the vicinity of the instrument (e.g. fields caused by transformers, radio-telephones, or electrostatic discharges).
- * Inductive loads (relays, solenoid valves etc.) should not be mounted close to the instrument, and should be fitted with RC modules to prevent interference.
- * Input, output and supply lines should be physically separated and not routed parallel to each other.
Out and return lines should be laid next to each other, and twisted together if possible.
- * Sensor and interface lines should be laid as twisted and screened cables. Do not route them close to current-carrying components or wiring. Ground the screen at one end to the PE terminal on the instrument.
- * Ground the PE terminal of the instrument to the protective earth of the supply. This wire must have a cross-section as least as great as the supply lines. Route the ground lines in a star configuration to a central grounding point that is connected to the protective ground wire of the supply. Do not loop ground lines, i.e. running them from one instrument to another.
- * Do not connect any other loads to the supply terminals on the instrument.
- * The instrument is not suitable for installation in hazardous areas subject to a danger of explosion.

If both analog inputs are being used, the potential difference between the negative connections must not exceed 5 V!

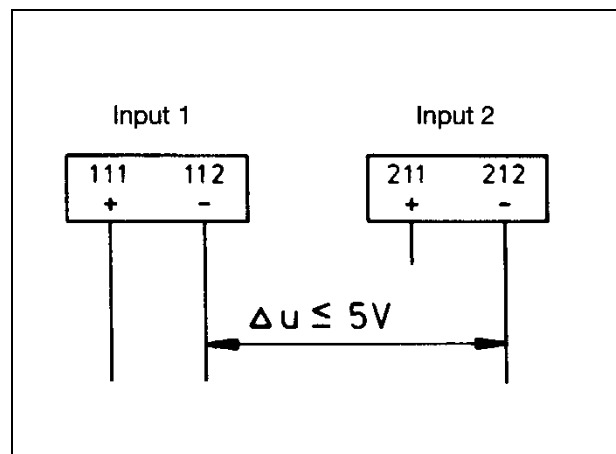

4 Operation

4.1 Levels and inhibits

For a clear presentation of the large number of possible adjustments, the parameters are arranged on three separate levels: operating level, parameter level and configuration level.

Standard display/operating level

The display normally shows the actual value for input 1. A different standard display can be selected at the configuration level (C 313).

The change to the operating level is operated by the Pgm key. The measurement of input 2, the stored measurements, minimum or maximum values, can be checked here in sequence (see Section 4.3).

Parameter level

The settings for the three alarm outputs are made here.

Configuration level

This level is used for adapting the inputs and outputs of the indicator, and for setting the required functions. The card-recognition of the option cards ensures that only those parameters are requested that correspond to the existing hardware. Internal DIL switches determine whether the indicator operates with the factory-set configuration data, or whether the data that are input by the user are applied.

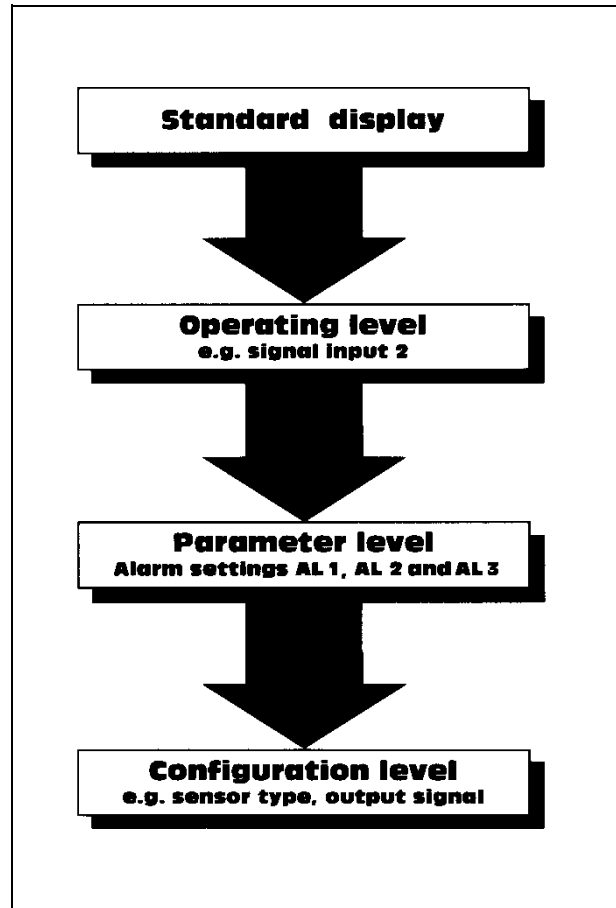

The three levels can be inhibited with internal switches (see Section 8).

Level	Inhibit
Operating level	access possible
Parameter level	access possible
Configuration level	access possible

4.2 Indicate measured value

In the standard display, the indicator normally shows the actual value on channel 1.

Other values can be selected under Code C 313 in the subdirectory Sd03 at the configuration level (see Section 6.4).

The LEDs CH1 and CH2 indicate which channel is being displayed at present. If measurements are combined (e.g. difference value) then both LEDs light up. If one of the channel LEDs blinks, this means that a stored value for this channel (e.g. minimum value) is being displayed.

Pressing the Pgm key changes to the operating level. A symbol for the measurement is displayed (e.g. InP2, see Table 4.3 below), and the corresponding value when Pgm is pressed again. If other variables have been configured, they can be called up in the same way. After the last value, the instrument setting returns to the standard display.

If no key has been operated for 30 sec. the instrument also returns to the standard display. The period for this time-out can be altered in the subdirectory Sd05 at the configuration level.

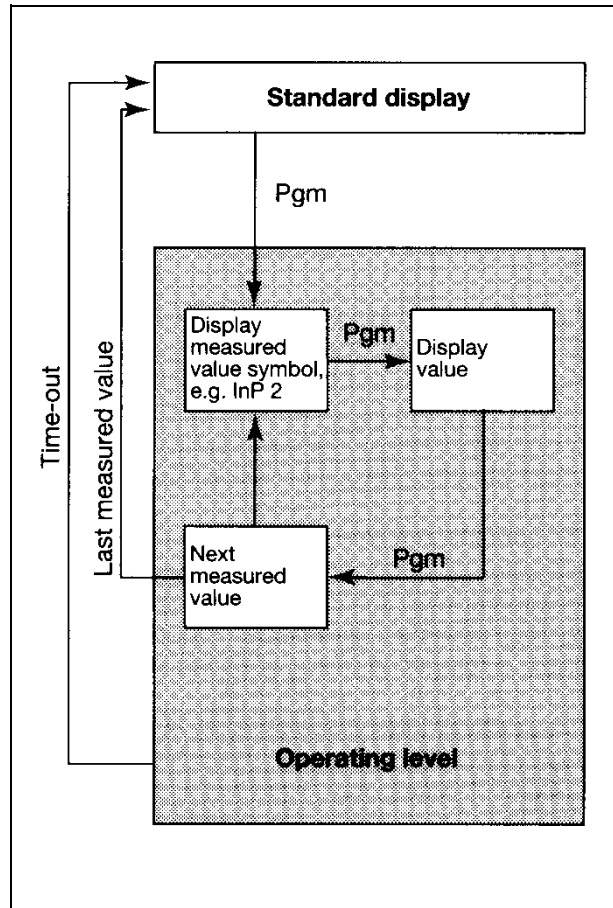

4.3 Table of variables that can be called up

Variable	Symbol
Actual value at input 1	InP1
Difference, humidity, or ratio value (actual)	ACt
Actual value at input 2	InP2
Maximum value at input 1 (High 1)	HI1 *
Maximum value at input 2 (High 2)	HI2 *
Minimum value at input 1 (Low 1)	Lo1 *
Minimum value at input 2 (Low 2)	Lo2 *
Stored value at input 1 (Hold 1)	HoL1 *
Stored value at input 2 (Hold 2)	HoL2 *

* These functions are activated through external contacts, see Section 9.1

5 Parameter level (alarms)

5.1 Alarms

Two independent limit comparators with 8 functions, and one limit comparator with two functions, recognise and signal if limits are exceeded. This is indicated by the two LEDs K1 and K2. The third output (limit comparator) does not have an indicator.

The output is, depending on the order specification, a relay, a logic level 0/5 V or a 1A semiconductor relay.

The alarm is cancelled as soon as the alarm condition is no longer present. The functions of the limit comparators lk1 to lk8, the reference value X_B and the switching differential X_d are all set in the subdirectory Sd02 at the configuration level.

The possible limit comparator functions are described on the following pages.

5.2 Indication and alteration of alarm settings

Pressing the \blacktriangle and Pgm keys simultaneously accesses the parameter level. The display shows the parameter symbol AL1 for the first alarm output. The corresponding setting is displayed when the \blacktriangleleft key is pressed.

The value can be altered by using the \blacktriangleleft key to select the digit and the \blacktriangle key to increment it. The value is entered with Pgm. Pressing Pgm twice calls up the second alarm output with the symbol AL2, whose setting can be altered in the same way. Pressing again calls up AL3.

Parameter level

Parameter	Symbol
Threshold for Alarm 1 *	AL 1
Threshold for Alarm 2 *	AL 2
Threshold for Alarm 3 *	AL 3

* Adjustment range ± 19999 digits

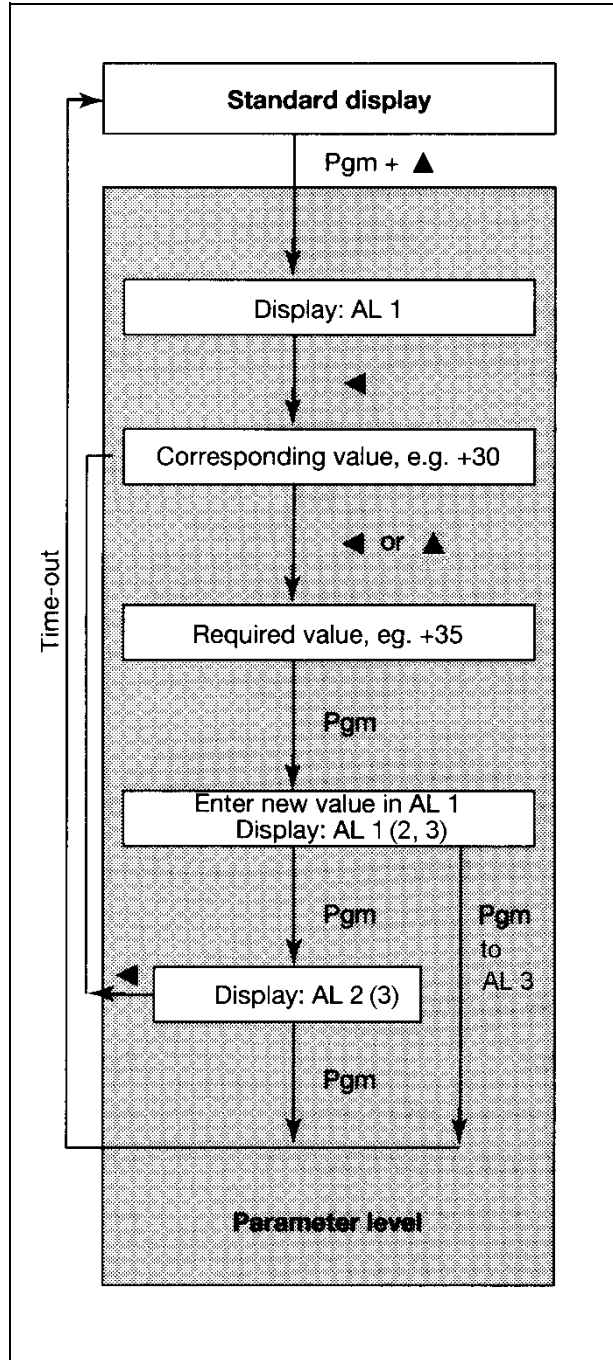

5 Parameter level (alarms)

5.3 Limit comparator functions

The differential X_d and the reference value X_B are set in subdirectory Sd02. The alarm setting AL is selected at the parameter level.

- ① **Function Ik1** Window function: the relay is energised when the indicated value is within a defined range.
 Example:
 $X_B = 200^\circ\text{C}$, $AL = 20$, $X_d = 10$
 Actual value rising: relay switches on at 185°C and off at 225°C .
 Actual value falling: relay switches on at 215°C and off at 175°C .

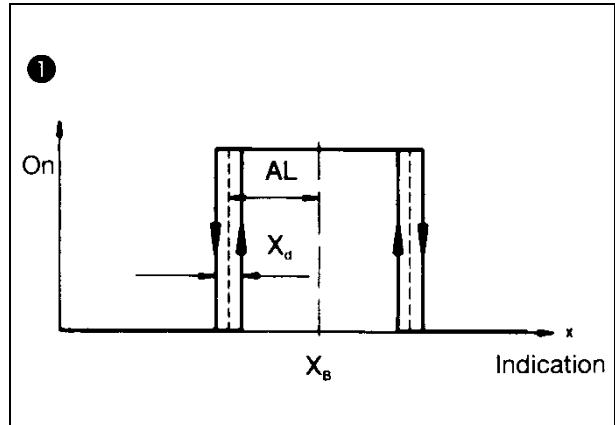

- ② **Function Ik2** Window function: the relay is energised when the actual value is above (reference value - alarm setting) and below (reference value + alarm setting).

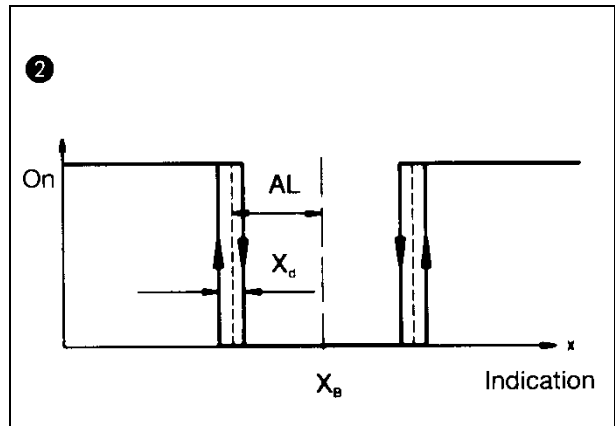

- ③ **Function Ik3** Low alarm: the relay is energised when the actual value is higher than (reference value - alarm setting).
 Example:
 $X_B = 200^\circ\text{C}$, $AL = 20$, $X_d = 10$
 Actual value rising: relay switches on at 185°C .
 Actual value falling: relay switches off at 175°C .

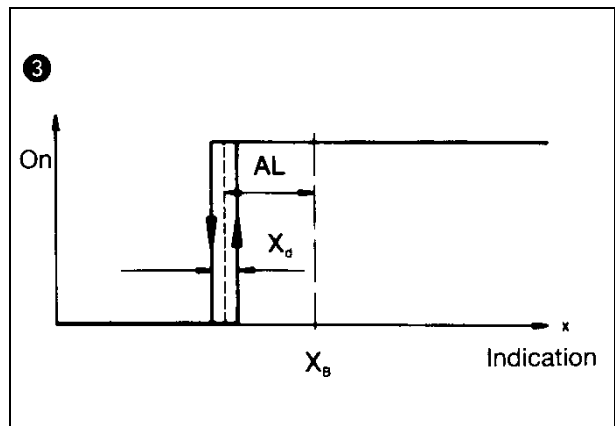

- ④ **Function Ik4** Low alarm: the relay is energised when the actual value is lower than (reference value - alarm setting).

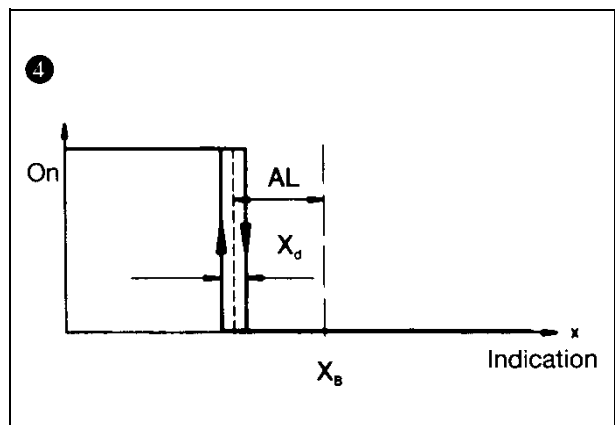

5 Parameter level (alarms)

5 Function Ik5 High alarm: the relay is energised when the actual value is lower than (reference value + alarm setting).

Example:
 $X_B = 200^{\circ}\text{C}$, $AL = 20$, $X_d = 10$
 Actual value rising:
 relay switches off at 225°C .
 Actual value falling:
 relay switches on at 215°C .

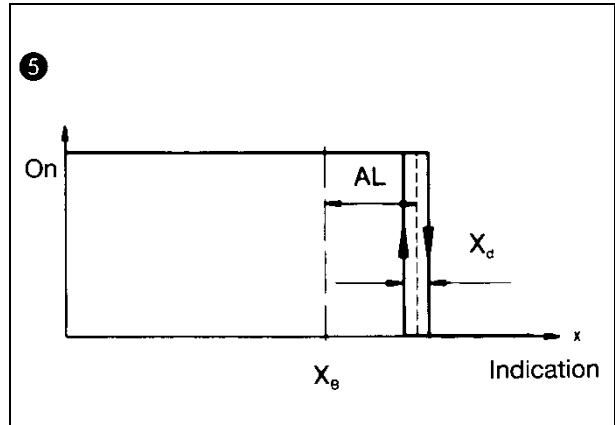

6 Function Ik6 High alarm: the relay is energised when the actual value is higher than (reference value + alarm setting).

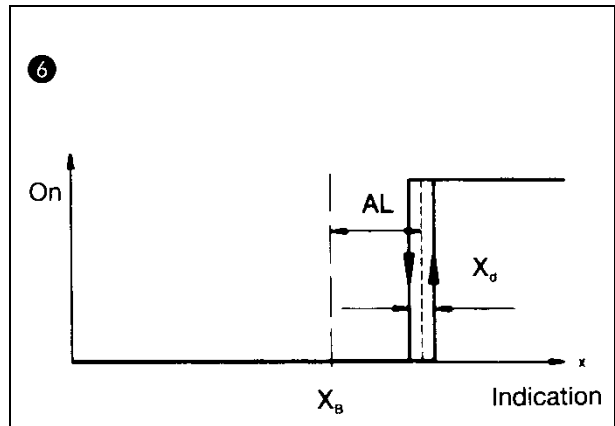

7 Function Ik7 Alarm depends only on the limit value AL. The relay is energised when the actual value is above the alarm level.

The relay is energised when the actual value is above the alarm level.
 Example:
 $AL = 200$, $X_d = 10$
 Actual value rising:
 relay switches on at 205°C .
 Actual value falling:
 relay switches off at 195°C .

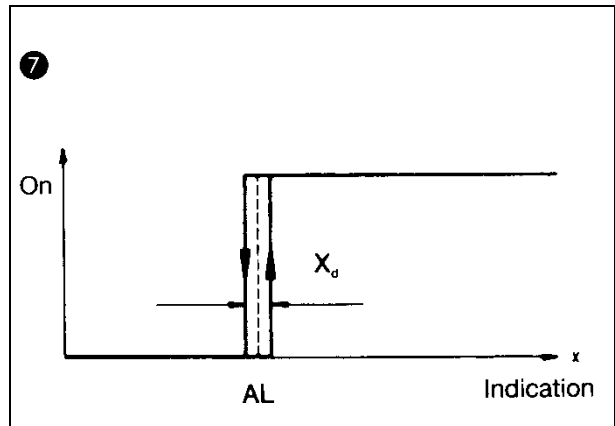

8 Function Ik8 Alarm depends only on the limit value AL. The relay is energised when the actual value is below the alarm level.

The relay is energised when the actual value is below the alarm level.

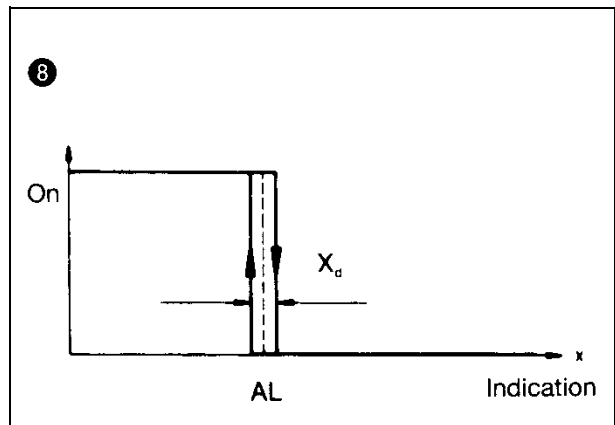

6 Configuration level

6.1 Finding subdirectories

The configuration level is accessed by pressing the ▲ and Pgm keys simultaneously.

The configuration data are divided into eight subdirectories Sd01 – 08.

Sd . .	Adjustment
01	Inputs 1 and 2
02	Outputs 1 and 2
03	External contacts
04	Interface
05	Special functions
06	Actual value correction
07	Customized linearisation
08	Hard/software recognition

The first subdirectory to appear is Sd01. The subsequent subdirectories are accessed with the Pgm key. The actual value outputs and relays are inhibited during configuration.

6.2 Displaying and editing configuration data

Access to the configuration level is only possible if it is not inhibited (see Section 8). After pressing the ◀ key, the first code of the subdirectory is displayed. The other codes can be called up by pressing Pgm. The corresponding value (number combination) is displayed with the ◀ key, and then edited with ▲ and ◀. The new value is entered with Pgm. The indicator is equipped with operator guidance that permits a return to the parameter level and then the standard display only if all necessary changes have been performed completely and with the correct logic. Following an incorrect input, the display will flash and request correction of the input.

Programming example

Input 1 (C 111) should have the following features:

- connection to thermocouple type L
- the transition from thermocouple cable to copper takes place at the instrument terminals
- display in °C

According to the configuration table (Section 6.3) this is represented by the number combination 0022 for C 111.

Programming then takes place according to the illustration at the right.

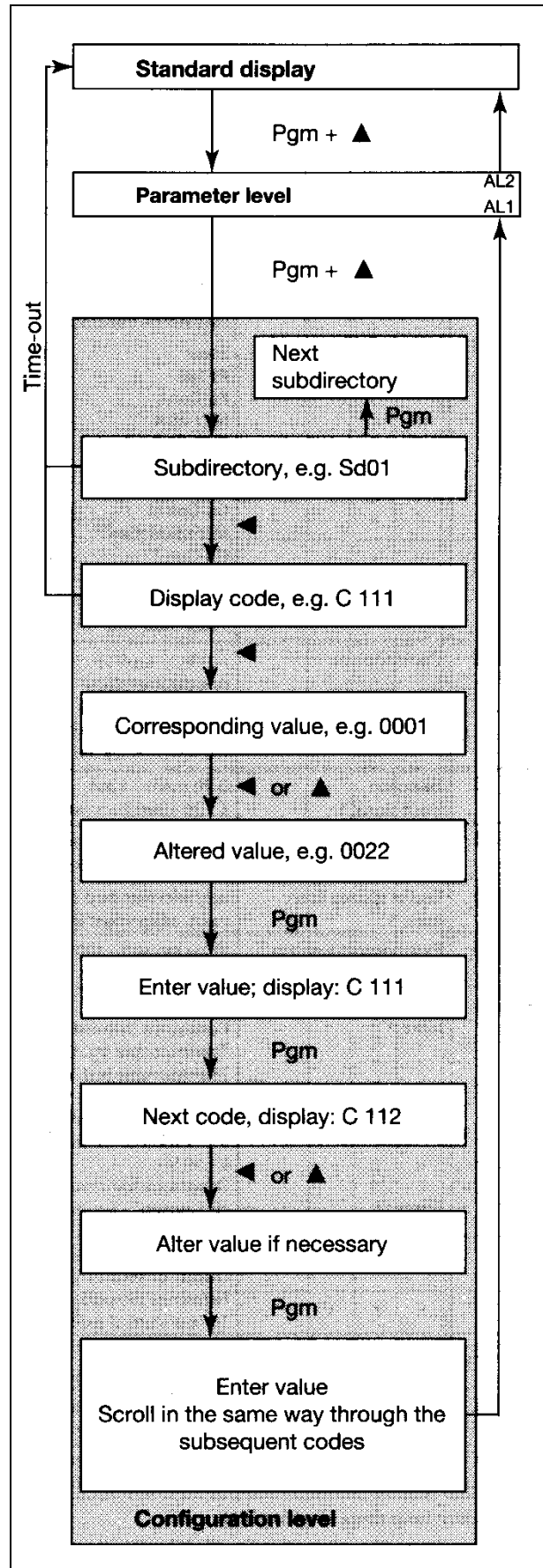

6 Configuration level

6.3 Configuration tables

Sd01	Inputs		1	0	0	0	0
C 111 ¹	Sensor type Input 1	Resistance thermometer Thermocouple (int. CJTC) or external cold junction Thermocouple (ext. cold junction: see C 116) 0 – 50 mV 0 – 20 mA / 4 – 20 mA 0 – 1 mA / 0.2 – 1 mA 0 – 10 V / 0 – 1 V Resistance transmitter					1 2 3 4 5 6 7 8
	Linearisation	linear –19999 +19999 digit Pt 100/500 – 200 + 850°C Fe-Con L – 200 + 1000°C NiCr-Ni K – 200 + 1400°C PtRh-Pt S 0 + 1800°C PtRh-Pt R 0 + 1800°C PtRh-Pt B 200 + 1820°C Cu-Con U – 200 + 600°C MoRe5-MoRe41 0 + 2000°C Cu-Con T – 200 + 400°C Fe-Con J – 200 + 900°C Customer-specific linearisation			0 0 0 0 0 0 0 0 0 0 1 1	0 1 2 3 4 5 6 7 8 9 0 1	
	Selection °C/°F	Temperature °C Temperature °F		0 1			
C 112 ¹	Decimal place	no decimal place one decimal place two decimal places three decimal places four decimal places					0 1 2 3 4
C 113 ¹	Selection input signal 1	0 – 20 mA / 0 – 1 mA 4 – 20 mA / 0.2 – 1 mA					0 1
C 114 ¹	Start of display span Input 1	only with standard signal and resistance transmitter input, assignment input signal → display	X	X	X	X	X
C 115 ¹	End of display span Input 1	only with standard signal and resistance transmitter input, assignment input signal → display	X	X	X	X	X
C 116 ¹	Ext. cold junc. temp.	Value range 0 – 100°C	–	–	X	X	X
C 121 ¹	Sensor type Input 2	not used Resistance thermometer Thermocouple (int. CJTC) Thermocouple (ext. cold junction: see C 116) 0 – 50 mV 0 – 20 mA / 4 – 20 mA 0 – 1 mA / 0.2 – 1 mA 0 – 10 V / 0 – 1 V Resistance transmitter					0 1 2 3 4 5 6 7 8
	Function	no function Ratio input (Input 1 / Input 2) Difference input (Input 1 – Input 2) Display of second measurement Reference temperature (dry temp.) for humidity Temperature of the external cold junction (Pt 100)		0 0 0 0 0 0	0 0 0 0 0 1	0 5 6 7 8 0	
C 123 ¹	Selection input signal 2	0 – 20 mA / 0 – 1 mA 4 – 20 mA / 0.2 – 1 mA					0 1
C 124 ¹	Start of display span Input 2	Only for standard signal and resistance transmitter input Assignment: input signal – display	X	X	X	X	X
C 125 ¹	End of display span Input 2	Only for standard signal and resistance transmitter input Assignment: input signal – display	X	X	X	X	X

X Input within the value range –19999 to +19999 digit

1. If one of these parameters is altered, then adjustment is required for resistance transmitter or standard signal input (see Section 10.2). Without adjustment, there may be a measurement error of up to ±1%.

6 Configuration level

Sd02	Outputs		1	0	0	0	0
C 221	Output 1 Type	not used					0
		Switching output					1
		Actual value output (0 – 20 mA, 0 – 10 V, –10 to +10 V, –20 to +20 mA)					2
		Actual value output (4 – 20 mA)					3
	Function	no function		0	0	0	
		lk1 referred to input 1 ¹ not possible for ratio		2	1	1	
		lk2 referred to input 1 ¹ not possible for ratio		2	1	2	
		lk3 referred to input 1 ¹ not possible for ratio		2	1	3	
		lk4 referred to input 1 ¹ not possible for ratio		2	1	4	
		lk5 referred to input 1 ¹ not possible for ratio		2	1	5	
		lk6 referred to input 1 ¹ not possible for ratio		2	1	6	
		lk7 referred to input 1 ¹		2	1	7	
		lk8 referred to input 1 ¹		2	1	8	
		lk7 referred to input 2 ¹		2	2	7	
lk8 referred to input 2 ¹		2	2	8			
Actual value output from input 1		3	0	1			
Actual value output from input 1		3	0	4			
Programmable analog output (via interface)		4	0	1			
C 222	Signal start Output 1	Assignment of output to indication range	X	X	X	X	X
C 223	Signal end Output 1	Assignment of output to indication range	X	X	X	X	X
C 224	Differential X_d of limit comparator (lk)	Value range 0 to 19999 digits	X	X	X	X	X
C 225	Ref. value X_B of limit comp. on output 1	not applicable on lk7 and lk8	X	X	X	X	X
C 231	Output 2 Type	not used					0
		Switching output					1
		Actual value output (0 – 20mA, 0 – 10V, –10 to +10V, –20 to +20mA)					2
		Actual value output (4 – 20 mA)					3
	Function	no function		0	0	0	
		lk1 referred to input 1 ¹ not possible for ratio		2	1	1	
		lk2 referred to input 1 ¹ not possible for ratio		2	1	2	
		lk3 referred to input 1 ¹ not possible for ratio		2	1	3	
		lk4 referred to input 1 ¹ not possible for ratio		2	1	4	
		lk5 referred to input 1 ¹ not possible for ratio		2	1	5	
		lk6 referred to input 1 ¹ not possible for ratio		2	1	6	
		lk7 referred to input 1 ¹		2	1	7	
		lk8 referred to input 1 ¹		2	1	8	
		lk7 referred to input 2 ¹		2	2	7	
lk8 referred to input 2 ¹		2	2	8			
Actual value output from input 1		3	0	1			
Actual value output from input 1		3	0	4			
Programmable analog output (via interface)		4	0	1			
C 232	Signal start Output 2	Assignment of output to indication range	X	X	X	X	X
C 233	Signal end Output 2	Assignment of output to indication range	X	X	X	X	X
C 234	Differential X_d of limit comparator (lk)	Value range 0 – 19999 digit	X	X	X	X	X
C 235	Ref. value X_B of limit comp. on output 2		X	X	X	X	X

X Input within the value range

1. For ratio measurement, the actual value is the value measured for input 1. For temperature difference or humidity, the actual value is derived from the values measured for inputs 1 and 2.

6 Configuration level

Sd02	Outputs		1	0	0	0	0
C 241	Output 3						
	Type	not fitted, or supply for 2-wire transmitter switching output					0 1
	Function	no function lk7 referred to input 1 lk8 referred to input 1 lk7 referred to input 2 lk8 referred to input 2		0 2 2 2 2	0 1 1 2 2	0 7 8 7 8	
C 244	Switching differential X _d of limit comparator (lk)	Value range 0 – 19999 digit	X	X	X	X	X

X = Input within the value range

6 Configuration level

Sd03	External contacts (see also Section 9.1)		1	8	8	8	8
C 313	External contacts						
	Contact 2 (terminals 82/83)	no function Keys inhibited Auto-tare * * = affects both Auto-tare reset * inputs of the Display blank and keys inhibited instrument Measured value store * Reset measured value store *					0 1 2 3 4 5 6
	Contact 1 (terminals 81/82)	no function Keys inhibited Auto-tare * * = affects both Auto-tare reset * inputs of the Display blank and keys inhibited instrument Measured value store * Reset measured value store *					0 1 2 3 4 5 6
	Standard display	Actual value input 1 Minimum value input 1 * * = only if external Maximum value input 1 * contacts are 2nd meas. value input 2 programmed Minimum value input 2 * as measure- Maximum value input 2 * ment store				0 1 2 3 4 5	
	Mains supply frequency selection	50 Hz to minimise the effect 60 Hz of supply-frequency interference		0 1			

Sd04	Interface		1	8	8	8	8
C 411	Interface type	Interface switched off					0 1 2
		RS232 RS422/485					
C 412	Data format	No parity					0
		Odd parity					1
		Even parity					2
		1 stop bit					
		2 stop bits					1 2
		7 data bits					
		8 data bits					7 8
		9600 baud					
		4800 baud					0 1 2 3 4 5 6
		2400 baud					
1200 baud							
600 baud							
300 baud							
150 baud							
C 413	Special function	Terminal mode off					0
		Terminal mode on					1
C 413	Special function	Termination CR					0
		Termination CR/LF					1
C 414	Unit address	Value range 0 – 31 digit					X X

X = Input within the value range

6 Configuration level

Sd05	Special functions		1	0	0	0	0
C 516	Signal on sensor break of channel 1 or 2 Output 1 If output 1 is a limit comparator, then:	Value range 000 – 100 % Output off Output on		0 0	X 0	X 0	X 1
C 517	Signal on sensor break of channel 1 or 2 Output 2 If output 2 is a limit comparator, then:	Value range 000 – 100 % Output off Output on		0 0	X 0	X 0	X 1
	Signal on sensor break of channel 1 or 2 for Output 3: see C 804						
C 518	Time-out	Value range 15 – 100 seconds			X	X	X
C 519	Identification number	Value range 0 – 19999 digit	X	X	X	X	X

X = Input within the value range

If an alteration of the actual-value correction is not intended, then exit the parameters C 611, C 612, C 621 and C 622 only by using ▲ + ◀ (return without any change) and not by using Pgm.								
Sd06	Actual-value correction and adjustment of the start and end values for input from resistance transmitters or standard signals			1	0	0	0	0
C 611	Customer-specific correction as in Section 10.1 (factory-set to 0/1 for resistance thermometer and thermocouple inputs)	X0	See Section 10.1 These Codes can only be selected directly when in the parameter level	X	X	X	X	X
C 612		X1		X	X	X	X	X
C 621		X0		X	X	X	X	X
C 622		X1		X	X	X	X	X
		Input 1						
		Input 1						
		Input 2						
		Input 2						

X = Input within the value range –19999 to +19999

Measured values for the programmed display (see Section 9.2) (Not programmable, values are only displayed)				1	0	0	0	0
C 613	X0	Input 1	0	–	–	–	–	–
C 614	X1	Input 1	1	–	–	–	–	–
C 623	X0	Input 2	0	–	–	–	–	–
C 624	X1	Input 2	1	–	–	–	–	–

– = Input within the value range –19999 to +19999

6 Configuration level

Sd07	Customer-specific linearisation		1	0	0	0	0
C 700	Number of value-pairs	Value range 0, 2 – 10				X	X
C 710	In 1	<p>In = measured value before correction</p> <p>Out = measured value required</p> <p>Value range –19999 to +1999</p> <p>Condition:</p> <p>Value of In 1 < In 2 < In 3 etc.</p>	X	X	X	X	X
C 711	Out 1		X	X	X	X	X
C 712	In 2		X	X	X	X	X
C 713	Out 2		X	X	X	X	X
C 714	In 3		X	X	X	X	X
C 715	Out 3		X	X	X	C	X
C 716	In 4		X	X	X	X	X
C 717	Out 4		X	X	X	X	X
C 718	In 5		X	X	X	X	X
C 719	Out 5		X	X	X	X	X
C 720	In 6		X	X	X	X	X
C 721	Out 6		X	X	X	X	X
C 722	In 7		X	X	X	X	X
C 723	Out 7		X	X	X	X	X
C 724	In 8		X	X	X	X	X
C 725	Out 8		X	X	X	X	X
C 726	In 9		X	X	X	X	X
C 727	Out 9		X	X	X	X	X
C 728	In 10		X	X	X	X	X
C 729	Out 10		X	X	X	X	X

X = Input within the value range

6 Configuration level

Sd08	Hardware and software version, hardware recognition (not programmable, can only be called up)		1	8	8	8	8
C 800	Version	Hardware version Software version		X	X	X	X
C 801	Extra functions	inhibited not inhibited		0 1			
C 802	Hardware recognition Interface	not fitted RS232 RS422/485		0 1 2			
	Range card Input 1	Pt 100, thermocouple, 0 – 50 mV 0 – 20 mA 0 – 1 mA 0 – 10 V, 0 – 1 V Resistance transmitter				0 1 2 3 4	
	Range card Input 2	Pt 100, thermocouple, 0 – 50 mV 0 – 20 mA 0 – 1 mA 0 – 10 V, 0 – 1 V Resistance transmitter					0 1 2 3 4
C 803	Hardware recognition Output 1	not fitted switching proportional			0 1 2		
	Output 2	not fitted switching proportional				0 1 2	
	Output 3	not fitted switching supply for 2-wire transmitter					0 1 2
C 804	Output 3 Signal on sensor break of channel 1 or channel 2	output off output on		0 0	0 0	0 0	0 1

In Sd08, the ▲ + ◀ key combination must be used in order to move from the number combination to the next Code display.

7.1 Error message

Er 11 * In spite of a fault in the processor sequence, the watchdog (internal monitoring device) has not been activated.

Remedy:

Cancel the error message by switching the supply off and then on again.

Er 20 * The data in the EEPROM are partly erased.

Remedy:

Read in the factory-setting data from the EPROM, i.e. switch off the supply, set the internal switches S301.5 to position 0 and S301.6 to position X, switch supply on again. If the error message appears again briefly, after switching on again, this has no significance.

The indicator will take up the data from the factory setting.

Another possibility:

Cancel the error message by pressing any key. The instrument is then in the configuration level, and the data can be re-entered/accepted. In addition, the values in subdirectory Sd06 at the configuration level must be checked and re-entered if necessary.

* The outputs switch off when the error occurs.

Er 30 Incorrect correction of the actual value. $X0 = X1$ or $X1 = 0$ has been entered.

Remedy:

The error message can be cancelled by pressing any key. The parameters X0 and X1 will automatically be set to standard values, i.e. the erroneous entry is ignored. Repeat the actual value correction if necessary.

Er 40 The display capacity is exceeded.

Remedy:

the number of decimal places (see C 112) must be reduced or, for programmable parameters, press the digit or increment key.

7.2 Action on supply failure

After a supply failure, the instrument returns to the standard display. The configuration level is an exception: in this case the configuration will be restarted.

7.3 Action on overrange or underrange

(also for sensor break or short-circuit)

On sensor break or short-circuit in channel 1 or 2, all the outputs take up a defined status (see C 516/517). The display flashes either the measured value or 19999.

After the fault has been cleared, the outputs will return to the normal function after some delay.

8 Adjustments inside the instrument

Actual value output

The output signal is set up by DIL switches. As described in Section 6.3 (subdirectory Sd02), the change from 0–20 mA to 4–20 mA is made in the software.

The indicator is supplied fully calibrated.

If the switches S1001.1 – S1001.4 are used to select a different output signal, then it may be necessary to make a slight re-adjustment of the output signal, using the trimmers R1030 and R1031. The output can also be a value provided by the interface, instead of the actual value.

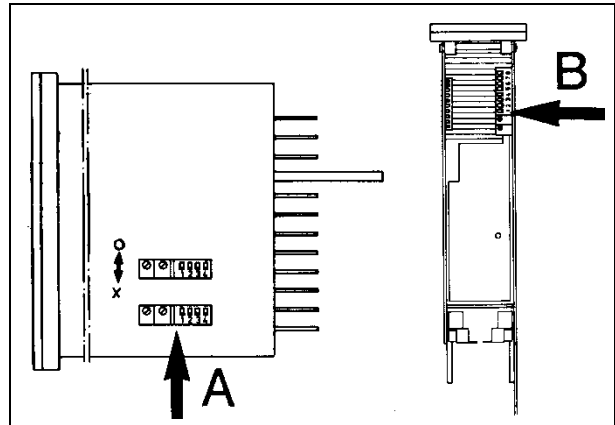

Actual value output 1 and 2

Signal \ Switch	S1001.1	S1001.2	S1001.3	S1001.4
0 – 10 V	O	X	X	O
-10/0/+10 V	X	X	X	O
0(4) – 20 mA	O	O	O	X
-20/0/+20 V	X	O	O	X

O = switched off
X = switched on

= standard setting

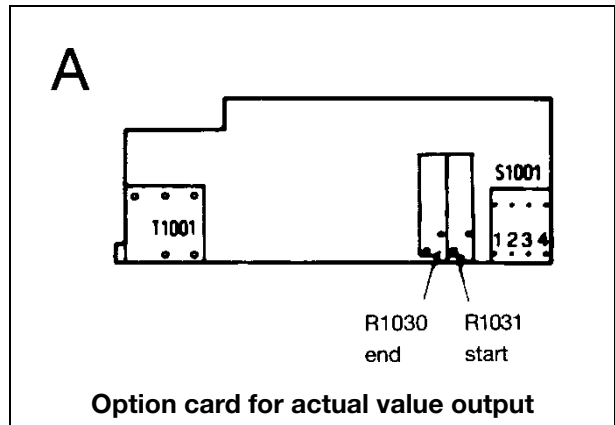

Option card for actual value output

Adjustment instructions for analog output

If an analog output is fitted as an add-on board, then an adjustment of the output signal will be necessary in every case.

Danger! The adjustment must only be carried out by professionally qualified personnel.



- * Disconnect the indicator on both poles from the supply.
- * Remove the indicator from the case (see Section 11).
- * Remove the four screws that attach the back panel to the case.
- * Pull off the back panel from the case, and plug it directly onto the indicator (protected against polarity reversal).
- * Position the indicator so that it is possible to operate it, and trimmers R 1030 and R 1031 are accessible.
- * Switch on the supply for the indicator.

Adjust output

- * Use a suitable source to provide the start value for the analog output.
- * Adjust the output value with R 103.

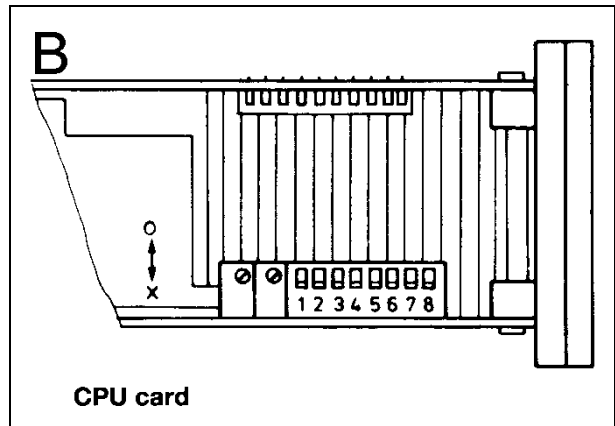

CPU card

- * Set the source to the end value for the analog output
- * Adjust the output value with R 1030.
- * Check the start value, and re-adjust if necessary.
- * Disconnect the indicator on both poles from the supply.
- * The re-assembly is carried out in the reverse of the order described above.

8 Adjustments inside the instrument

Acceptance of data

The configuration data and parameter data are read out from the EPROM into the working memory (RAM) if S206.5 is in position O and S206.6 is in position X.

This means that the parameters can be called up, but not altered.

As delivered (S206.5 in position X and S206.6 in position O), the indicator can be programmed without any limitation.

If the switches S206.5 and S206.6 are in position O, then only the parameter data can be altered.

If the factory-setting data have to be accepted, after faulty programming, then S206.5 must be set to position O and S206.6 to position X for about 2 minutes.

The outputs should be disconnected during this process, since their status is undefined during the data transfer.

- X = on, switch is closed
- O = off, switch is open
- = factory setting

Factory setting	S206.5	S206.6
Yes	O	
No	X	
Accept in the configuration level		O
Configuration and parameter levels		X

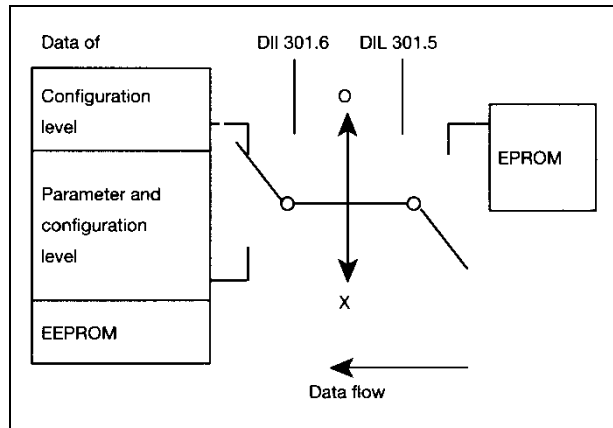

Input filter

A digital filter for smoothing the input signal. The time constant is 1.4 sec.

Switches 3,7 and 8 are not used.

Input filter	S206.4	
On	O	
Off	X	

Level inhibit

Access to these levels is not possible

Access to these levels is not possible

Access to this level is not possible

All levels are available

Level inhibited	S206.	
	1	2
Operating level (call-up only) Parameter level Configuration level	O	X
Parameter level Configuration level	X	O
Configuration level	O	O
no inhibit	X	X

9 Extra functions

9.1 Functions of the external contacts

The following functions (see C 313) can be implemented by using the two external contacts (do not apply an external voltage):

- automatic tare
- key inhibit
- storing a measured value or an extreme value
- display off

The response time of the external contacts can be up to 1 second. The functions can be selected at the configuration level

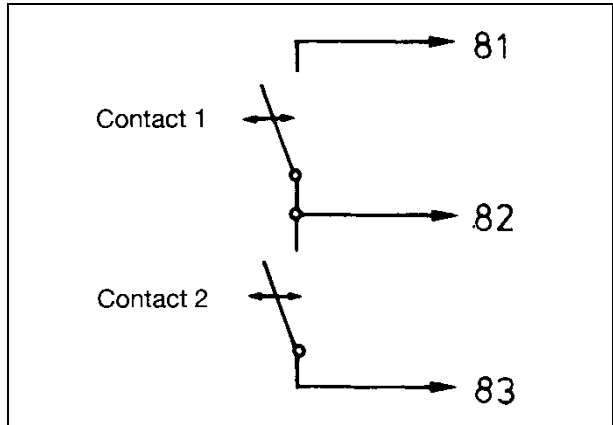

Automatic tare

This is used for difference measurements where the measurements have to be added together – in weighing, for instance.

Automatic tare is only possible with linear standard input signals and resistance transmitters. Furthermore, input 2 must be configured as “Display second measurement” or “no function”.

The external “Auto-tare” key is used to reset the display to 0 from any value. This does not change the output signal of the actual value output.

The function is cancelled with the external key “Auto-tare reset”, i.e. the actual value appears again in the display.

A brief contact closure (at least 1 sec.) activates the corresponding function for both measurement channels.

The LED for the channel blinks when the tare value is displayed for that channel. The outputs are determined by the actual measurement, not by the tare value.

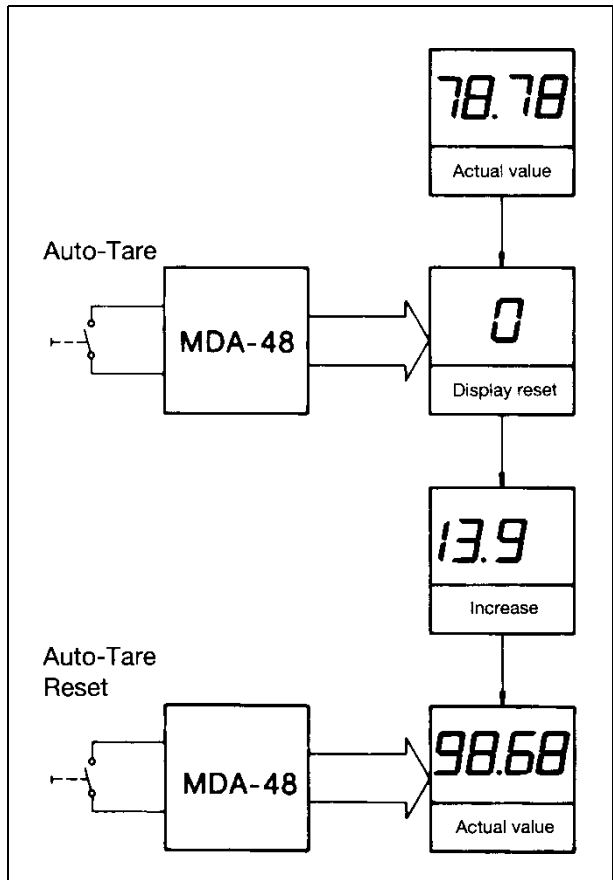

Application example (see diagram at right):

The amount of a substance mixed from several components is to be measured. The initial weight is 78.78 gm. 13.9 gm of another substance are to be added. Before the addition (display stands at 78.78 gm), the “Auto-tare” key is pressed. The display changes to “0”.

The amount of the substance that is added can now be read directly.

After pressing the key “Auto-tare reset”, the total weight appears again in the display.

Key inhibit

Key operation is impossible while the contact is closed.

Application: security measure against unauthorised operation, e.g. by using a keyswitch.

Storing a measured value

The stored measurements (extreme values or momentary values) can be called up at the operating level (see Section 4.3) under the appropriate designation, e.g. HI1 = maximum value for channel 1.

One of these values can also be configured as the standard display (see C 313 at the configuration level).

The extreme values “Min 1(2)” and “Max 1(2)” can be reset by briefly closing the contact “Measured value store reset”. The minimum and maximum value stores are updated every 400 msec.

A brief (1 sec.) closure of the contact “Measured value store” accepts and stores the momentary value as “HoL1” or “HoL2”.

The stored value appears on the display as long as the contact remains closed. When the contact is opened, the actual value appears again in the display. Measured value storage is performed simultaneously on both channels.

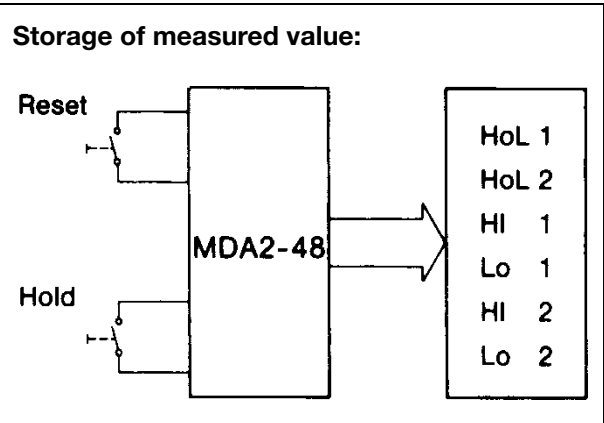

Switching off the display

The display can be switched off by closing the switch, for instance when the light from the display has a disturbing effect (photography). Opening the switch turns on the display once more.

The keys are inhibited while the display is switched off.

9.2 Scroll function (automatic display change)

The scroll function is activated by pressing the key while in the standard display. Pressing the key again cancels the function.

If channel 2 is not available, or if the logic inputs are configured as measured value storage inputs, then it is not possible to switch on the scroll function.

After activating the scroll function, the channels 1 and 2 are displayed alternately in a 5-second rhythm. The corresponding channel lights up at the same time.

The scroll function will not continue after a mains supply failure.

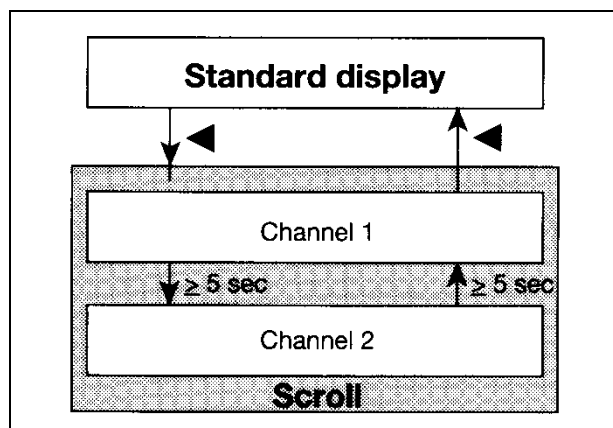

9 Extra functions

9.3 Humidity measurement

(C 121* = 0081)

The instrument permits rH measurement independently of any reference temperature.

Function:

Relative humidity is measured on the psychrometric principle. The measurement is independent of reference temperature.

Input 1 (Pt 100/100) = wet temperature

Input 2 (Pt 100/500) = dry temperature

The humidity measurement only functions if the dry and wet temperatures are within the range 0 to 100°C and if the calculated value for the relative humidity is between 0% and 100% rH. The display shows the relative humidity in%. Both channel LEDs light up.

Channel 2 shows the dry temperature (master temperature).

9.4 Ratio measurement

(C 121* = 005X)

The indicator operates with two current, voltage or resistance transmitter inputs in any combination. The display range covers 0.01 to 199.99.

The standard display shows the ratio of input 1 to input 2. The LEDs for both channels light up. The signal at the actual value output does however correspond to the measured value of channel 1.

9.5 Difference measurement

(C 121* = 006X)

In order to measure the difference, it is necessary that both inputs operate from identical transducers. The display shows the value of input 1 minus the value of input 2. The difference appears as the actual value output.

The measured value of input 2 can, as for all combined measurements, be called up under "InP2". Both channels LEDs light up.

9.6 Segment test and call-up of software version

If the Pgm and  keys are pressed simultaneously, the software version appears first, as long as the keys are still pressed, and then all display segments and LEDs light up for a few seconds.

* see subdirectory Sd01

10 User-specific settings

10.1 Actual value correction

An actual value display that differs from the desired or actual value can be corrected by using the keys. This may be useful, for example, to adjust the readings from several instruments to match each other, or to compensate for the lead resistance of the sensor cable.

Two values are entered, intermediate values are interpolated or extrapolated by the indicator.

Example:

At a measured value of 15°, the display should read 40.

At a measured value of 90°, the display should read 60.

Programming:

At a measured value of 15, the parameter X0 (C 611 / C 621) is programmed as 40. This moves up the *entire* measurement characteristic by 25 (15 +25 = 40).

The original value of 90 is also increased by 25, to 115.

The second correction, using X1, must therefore be made at 115 (90 +25 = 115).

At a measured value of 115, the parameter X1 (C 612/C 622) is programmed as 60.

After this correction, using X0/X1 there is, for channel 1 in this example:

40	for X0	in C 611
15	for X0'	in C 613
60	for X1	in C 612
90	for X1'	in C 614

The corrections should be made close to the start and end points of the measuring range, so that there is a sufficiently large spacing between X0' and X1'.

In order to return to the basis status X1 = 0 must be programmed. This causes the error message Er30 to appear, which can then be cancelled by pressing any key. As a result, X0 and X0' are set to 0, and X1 and X1' are set to 1.

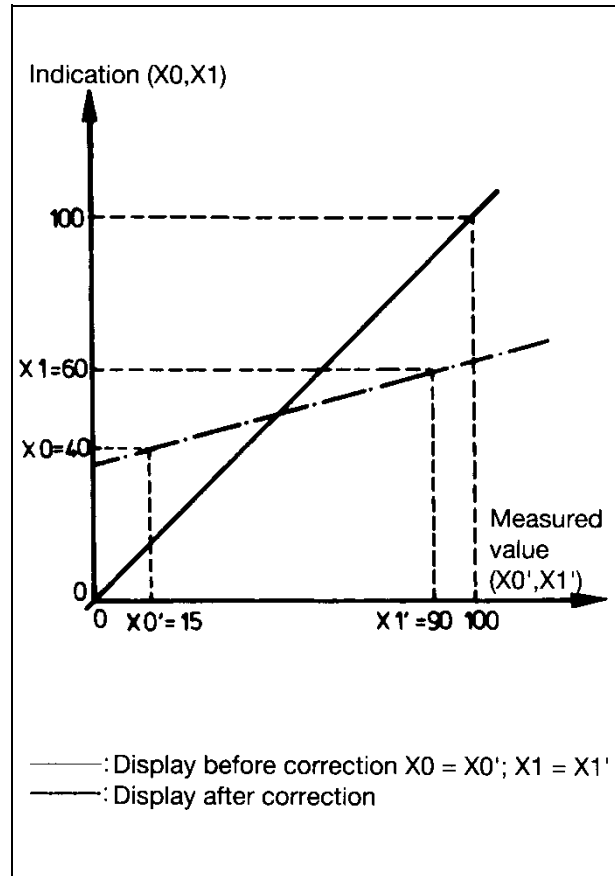

If one of the parameters C 111 — C 115 or C 121 — C 125 is altered, then the actual value correction must be done again.

A adjustment is necessary for standard signal or resistance transmitter inputs. If no adjustment is made, an error of up to ±1% may occur.

* The appropriate signal must be applied to the input.

10 User-specific settings

10.2 Calibration of indication

(for resistance transmitter or standard signal input)

With resistance transmitters and standard signals it is possible to assign a specific displayed value to the maximum and minimum values of the input signal. Linear interpolation is provided between these values (see configuration level C 114/C 115 or C 124/C 125). The calibration is automatically set to 0 – 100% for resistance transmitters. A correction is only required if the slider cannot be set to zero.

Adjusting the start of the display range:

Set the resistance transmitter to the start position. Select Code C 611/ C 621. Input 0% and confirm with the Pgm key.

Adjusting the end of the display range:

Set the resistance transmitter to the end position. Select Code C 612/ C 622. Input 100% and confirm with the Pgm key.

10.3 Calibration of start and end of output signal

On the actual value output, an output signal can be assigned to a particular reading. The adjustment is made for the start and end values of the display.

Example:

The range for a thermocouple Type U is -200 to $+600^{\circ}\text{C}$. With an actual value output range of $4 - 20$ mA, the output should be 4 mA at -200°C and 20 mA at 600°C .

If the signal start (C 222/C 232) is programmed to 0°C and the signal end to (C 223/C 233) to 200°C , then the output will be 4 mA for 0°C and 20 mA at 200°C .

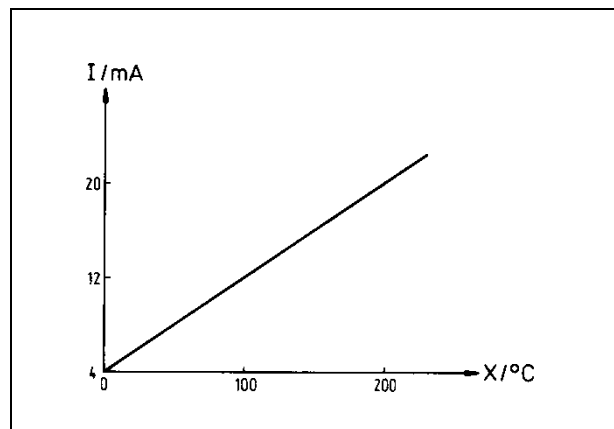

10 User-specific settings

10.4 Determining the cold junction temperature for thermocouples

The temperature at the transition from thermocouple wire to copper wire (cold junction temperature) must be known or measured.

There are three possibilities:

Internal cold junction temperature

The change from thermocouple wire to copper wire takes place at the terminals of the instrument. The temperature at the terminals is measured by an internal Pt 100 resistance sensor.

External cold junction temperature with regulated cold junction

The change from thermocouple wire to copper wire takes place at a heated cold junction. The temperature of this cold junction must be entered in configuration code C 116 (applies to both inputs).

Measuring the external cold junction

The change from thermocouple wire to copper wire takes place somewhere between the probe and the indicator. The temperature at the transition point must be measured by using a Pt 100 resistance thermometer (input 2).

This has to be configured accordingly.

10 User-specific settings

10.5 Customer-specific linearisation

From 2 to 10 points within the range of the display can be entered for this linearisation, that is individually adapted for a specific transducer. In this way, corrections can be made for non-linearity in the transducer characteristic. A linear interpolation is made between these points.

The pairs of values are entered in subdirectory Sd07:

In 1 ... 10 — Out 1 ... 10

(Display before correction — desired display after correction)

The measured values that are to be corrected must be entered in increasing order (value for In 1 < value for In 2 < value for In 3 etc.).

Linearising a 0 – 100 mbar pressure transmitter, with a 0 – 20 mA output.

The display value before correction can be taken either from the known characteristic of the transmitter, or determined experimentally.

Example:

The pressure to be measured is 0 to 80 mbar. At 15 mbar the transmitter outputs 3.3 mA instead of the ideal value 3.0 mA. Since 20 mA corresponds to a display of 100.0, then 3.3 mA corresponds to a display of 16.5, before correction.

Meas. point no.	Press. [mbar]	Transmitter output [mA]	Display before correct.	Display value wanted
1	0	0.52	2.5	0.0
2	15	3.3	16.5	15.0
3	30	6.2	31.0	30.0
4	40	9.2	46.0	40.0
5	60	11.4	57.0	60.0
6	75	14.71	73.5	75.0

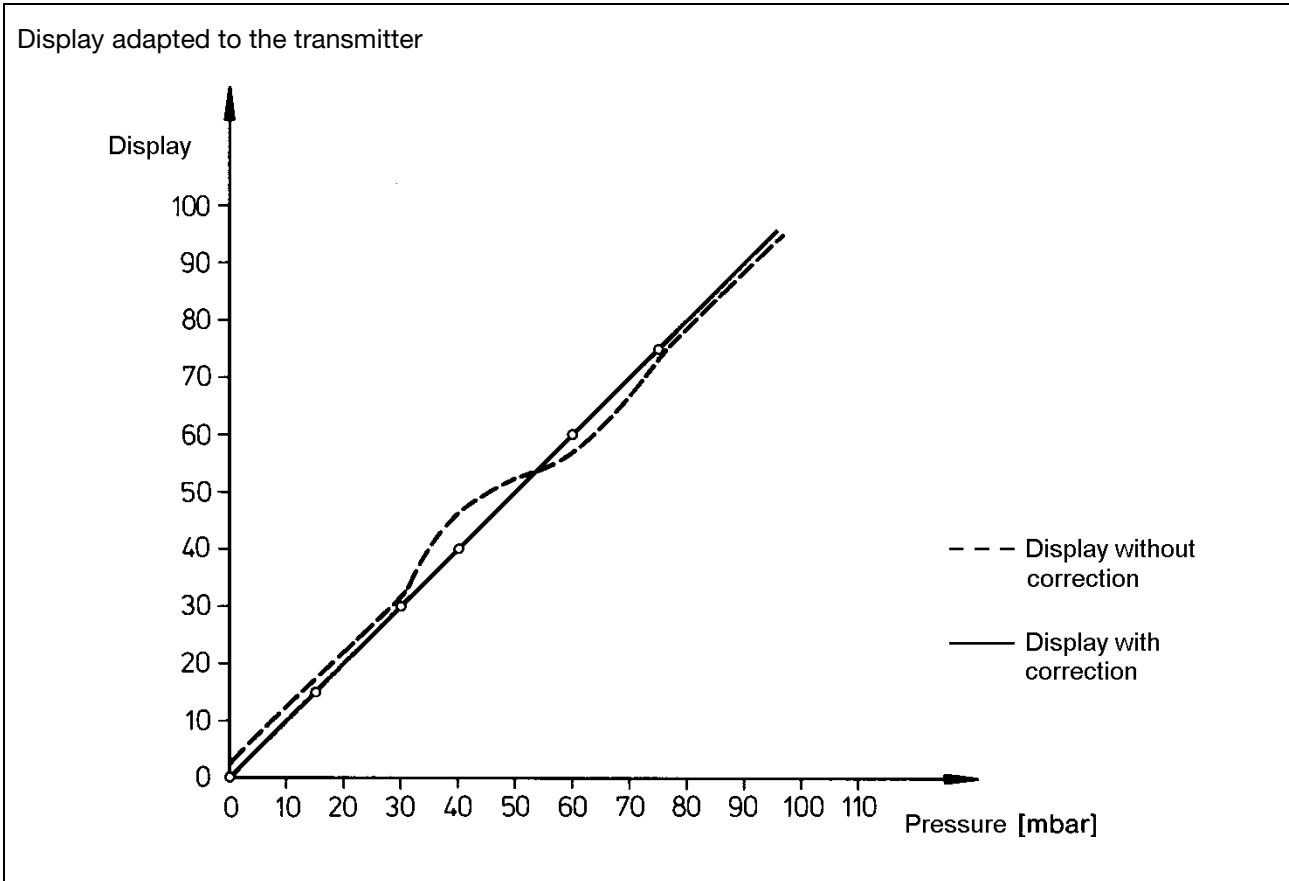

10 User-specific settings

Programming the value pairs

Open subdirectory Sd07.
Program the number of value pairs (C 700) and the value pairs themselves (C 710 ... C 721).

During programming, the input signal that is present is irrelevant.

If, during a measurement, the measured value is outside the range of correction that was previously defined, then the first and last pairs of values will be used for linearisation. The extrapolation will be made according to the straight line created by these points.

The customer-specific linearisation will be ineffective if C 700 is programmed to zero.

Designation	Code	Entry
No. of value pairs	C 700	6
In 1 Out 1	C 710 C 711	2.5 0.0
In 2 Out 2	C 712 C 713	16.5 15.0
· · In 6 Out 6	· · C 720 C 721	· · 73.5 75.0

Changing the decimal point

After a change of the decimal point position, the configuration data – including the values for the customer-specific linearisation – must be confirmed.

If standard signal input or resistance transmitter input is used, then the display range should be re-adjusted (see Sections 10.1 and 10.2). The customer-specific linearisation must be switched off during this activity.

Program C 700 = 0 as well, and correct the display range as described in Section 10.1. Afterwards, program the original number of value pairs again in C 700, and confirm the configuration data.

10 User-specific settings

10.6 Table of settings

(for parameter and configuration data)

As a guidance for later modifications of the display data, the programmed parameter and configuration data should be entered here. Some of the parameters may be omitted, depending on the indicator version.

Configuration data

Sd01	C 111					
	C 112					
	C 113					
	C 114					
	C 115					
	C 116					
	C 121					
	C 123					
	C 124					
	C 125					
Sd02	C 221					
	C 222					
	C 223					
	C 224					
	C 225					
	C 231					
	C 232					
	C 233					
	C 234					
	C 235					
	C 241					
	C 244					
Sd03	C 313					
Sd04	C 411					
	C 412					
	C 413					
	C 414					
Sd05	C 516					
	C 517					
	C 518					
	C 519					

Parameter data

AL 1						
AL 2						
AL 3						

Sd06	C 611					
	C 612					
	C 613					
	C 614					
	C 621					
	C 622					
	C 623					
	C 624					
Sd07	C 700					
	C 710					
	C 711					
	C 712					
	C 713					
	C 714					
	C 715					
	C 716					
	C 717					
	C 718					
	C 719					
	C 720					
	C 721					
	C 722					
	C 723					
	C 724					
	C 725					
	C 726					
	C 727					
	C 728					
	C 729					
Sd08	C 800					
	C 801					
	C 802					
	C 803					
	C 804					

11 Retrofitting of cards

Various retrofit-cards are available if it is necessary to expand or modify an instrument. They are summarised at the end of this section, and can be ordered individually.

The procedure for changing the cards is described below. A change of hardware also requires alterations at the configuration level.

- ❶ Release the knurled screw at the back
- ❷ Pull out the chassis (if necessary, push on the threaded stud at the back)

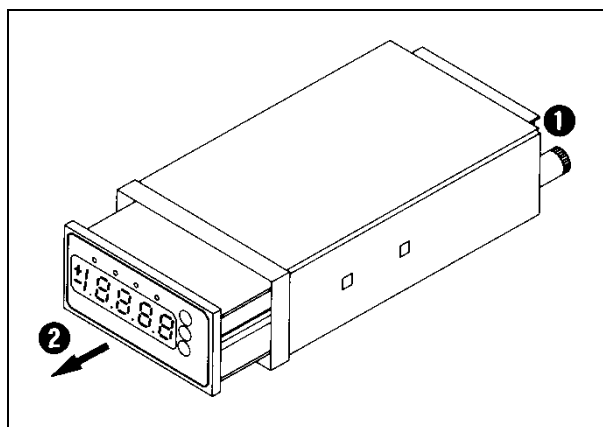

- ❸ Remove the screws

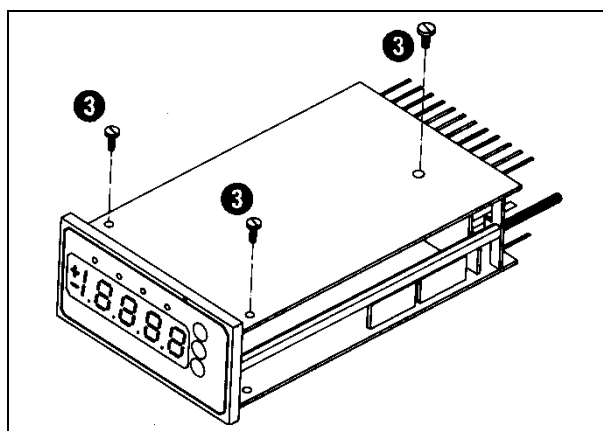

11 Retrofitting of cards

④ Swing the top card over in the direction of the arrows

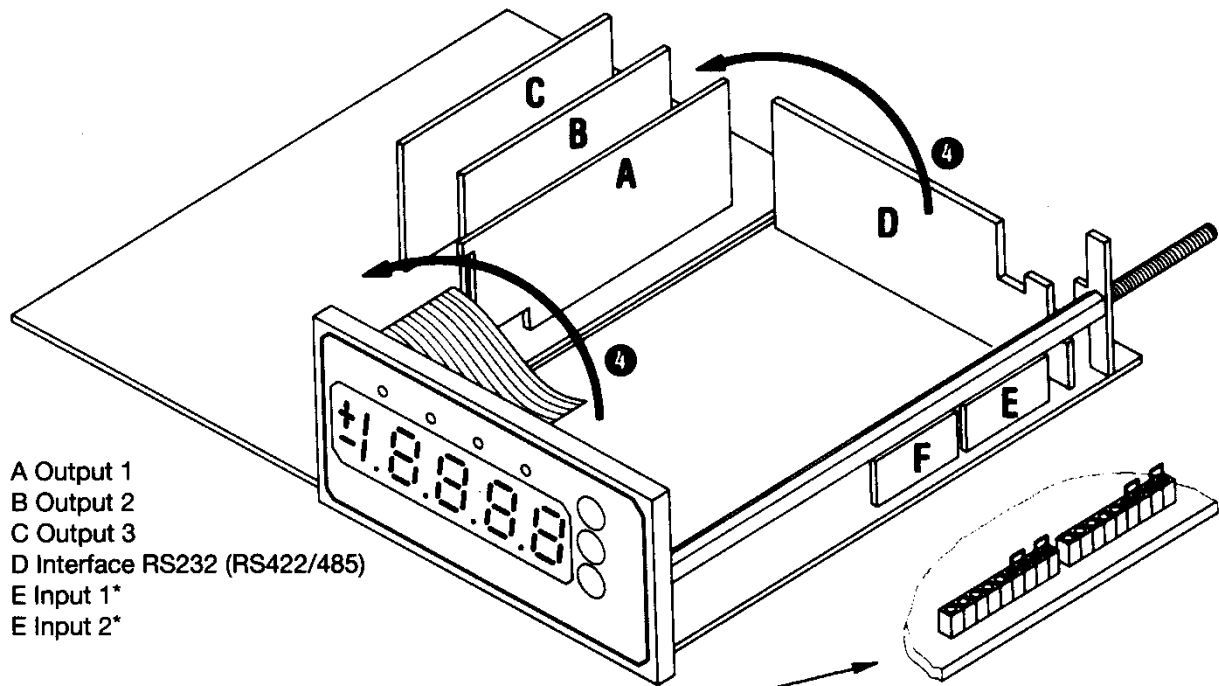

* wire links in case of resistance thermometer and thermocouple input

Table of retrofit-cards

Description	Plug-in position	Order No.*
Interface RS422/485	D	91307
Interface RS232C (V.24)	D	91308
Input module for standard current signal	0(4) – 20 mA	91309
	0 – 1 mA	91310
Input module for standard voltage signal	0 – 10 V	91312
	0 – 1 V	91313
Input module for resistance transmitter	E, F	91311
Semiconductor relay output	A, B, C	91316
Relay output	A, B, C	91317
Logic output	A, B, C	91322
0/ 5 V or 0/20 mA without electrical isolation	A, B, C	91323
0/20 V or 0/20 mA with electrical isolation	A, B, C	
Analog output (selectable current/voltage)	A, B	91938
Auxiliary supply for 2-wire transmitter	C	91315
Wire link for resistance thermometer and thermocouple input (1 item)	E, F	66989

* corresponds to the last five places of the item number on the board
 Carry out an adjustment/calibration after swapping or adding boards (see Section 10.2).



MEASUREMENT AND CONTROL

M.K. JUCHHEIM GmbH & Co.

36035 Fulda
Germany
Phone ++49 6 61-60 03-0
Fax ++49 6 61-60 03-6 07
Telex 49 701 juf d
email JUMO_de@e-mail.com

United Kingdom

JUMO Instrument Co. Ltd.
Temple Bank, Riverway
GB-Harlow,
Essex CM20 2TT
Phone (0 12 79) 63 55 33
Fax (0 12 79) 63 52 62

USA

JUMO PROCESS CONTROL INC.
735 Fox Chase,
Coatesville, PA 19320
Phone 610-380-8002,
800-554 JUMO
Fax 610-380-8009