

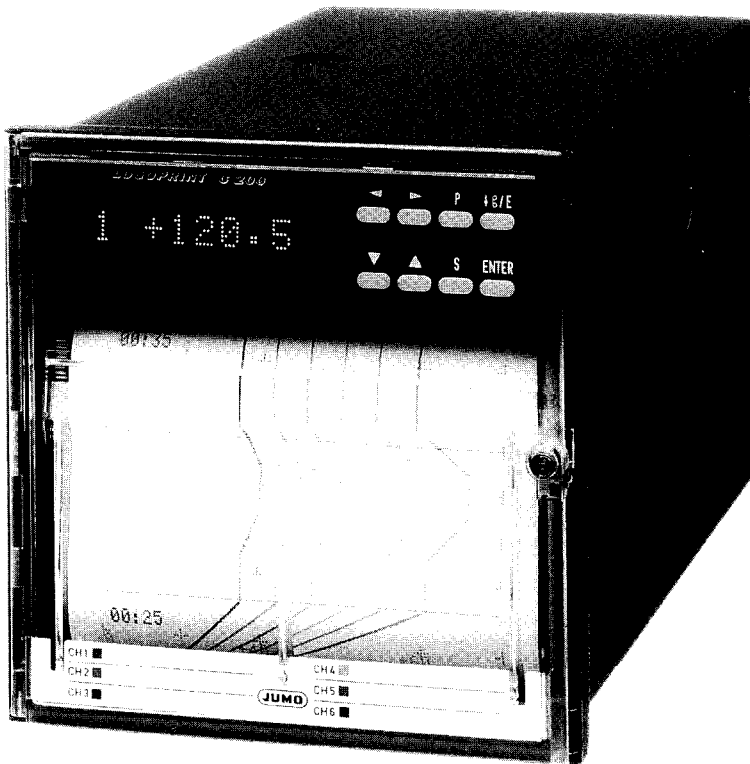

MEASUREMENT AND CONTROL

LOGOPRINT[®] C200/C240

**6-colour Printing Recorder
with fully isolated analogue inputs**



B 95.4015.2/4016.2 (D 92.560.2/561.2)

10.93/V 85093

Interface description

M. K. JUCHHEIM & CO . **36035 FULDA** . **GERMANY**
Phone (0661) 60 03-0 . **Fax (0661) 60 03-607** . **Teletex 6619726**

CONTENTS

	Page
1 GENERAL NOTES	3
1.1 Introduction	3
1.2 Electrical connection	3
1.3 Interface parameters	3
1.4 Transmission protocol	3
1.5 Codes for interface communication	5
1.6 Error handling	7
1.7 Error messages referring to a communication via the serial interface	7
1.8 Termination character	7
1.8.1 Termination character of the command	7
1.8.2 Termination character of response (from slave)	7
1.9 Character set	7
1.9.1 Transmission from the LOGOPRINT to the master	7
1.9.2 Transmission from master to LOGOPRINT	7
1.9.3 Arrangement of the software	7
2 SYNTAX OF ALL COMMANDS AND POSSIBLE RESPONSES	8
2.1 Process value	8
2.2 Error message	8
2.3 Alarm	8
2.4 Relay activation	9
2.5 Status (device status word)	9
2.6 Group read-out	10
2.7 Chart speed	10
2.8 Plot status	10
2.9 Programming levels P and C	10
2.10 Date	10
2.11 Time	11
2.12 Summer time	11
2.13 Piezo beeper	11
2.14 Filter constant	11
2.15 Channel status	11
2.16 Channel designation	11
2.17 Ranges	12
2.18 Decimal place, unit	12
2.19 Scaling	13
2.20 Limit setting for first and second lk	13
2.21 Relay on/off	13
2.22 Relay alarm text	13
2.23 Limit range for out-of-limit chart speed	13
2.24 Plotting range (PLOTAREA)	14
2.25 Offset range	14
2.26 Instrument designation	14
2.27 Beginning text	14
2.28 End text	14
2.29 Relay lk selection	14

CONTENTS

	Page
2.30 Chart speed	14
2.30.1 Chart speed at FEED LIMIT	14
2.30.2 Chart speed at FEED EXTERN	15
2.30.3 Chart speed at FEED TIME	15
2.31 Limit acknowledgment	15
2.32 Reports	15
2.32.1 Daily report	15
2.32.2 Measuring period report	15
2.32.3 Message report	15
2.33 Text for external contact	15
2.34 Counter (for external contact)	15
2.35 EC DIR	16
2.36 Print-out of a text report	16
3 SPECIAL FEATURES OF THE INTERFACES	17
3.1 Interface RS232	17
3.1.1 Interface operation without handshake	17
3.1.2 Interface operation with handshake	17
3.2 Interfaces RS422/485	17
3.2.1 Differences in the commands compared with RS232	17

1 GENERAL NOTES

1.1 Introduction

The interfaces RS232 (also known as V.24), RS422 and RS485 provide for data communication with computers or host control systems.

The RS232 (V.24) permits connection of one indicator per computer interface. The interfaces RS422 and RS485 provide for connecting up to 31 devices per computer interface to a data bus, i.e. the connection to one or two common conductor pairs.

To distinguish between them the indicating instruments are provided with different device numbers. With regard to the software the two interfaces are treated similarly.

1.2 Electrical connection

Where possible, screened cables should be used to connect up the interfaces; twisted lines are often adequate in the case of the RS422/485. The screen has to be connected to the housing potential (PE).

The maximum cable length depends on the quality of the screening and the amount of electromagnetic interference. It is approx. 30 m with the RS232, and about 1200 m in the case of the RS422/485.

When connecting up the RS232 interface it is possible to omit handshake lines. The corresponding connections on the indicator then remain open-circuit.

RS 232	RS 422	RS 485
91 RxD	A(+) transmitting	A(+) transmitting/ B(-) receiving pair
92 TxD	B(-) pair	
93 RTS	A(+) receiving	
94 CTS	B(-) pair	
95 GND	GND	GND

1.3 Interface parameters

Designation	Range	Standard values
device address	00 to 31	
baud rate	150 to 9600 baud	9600 baud
data word	7 bit, 8 bit	8 data bits
parity	no, odd, even	no parity
stop bit	1 bit, 2 bit	1 stop bit

Note: the device address applies only to the RS422/485

1.4 Transmission protocol

The characters are transmitted in ASCII code.

Example of a parameter not related to a channel:

Command from master to JUMO LOGOPRINT C

FEEDP <blank> 5 <Cr> (<Lf>)

Interpretation:

FEEDP => chart speed
 < > => encloses control characters
blank => blank character (this is essential)
 5 => chart speed 5 mm/h
 () => not essential
Cr/Lf => termination character

Note:

Any number of blank characters can be inserted before the code "FEEDP", the value "5" and the termination character "Cr/Lf". The number of characters of a complete command must however not exceed 30.

Response of the JUMO LOGOPRINT C

OK<Cr>

Interpretation:

OK => value has been checked and entered
 < > => encloses control characters
Cr => termination character

Example of a parameter referring to a particular channel:

Command from master to JUMO LOGOPRINT C:

PLOTS<blank> CH1<blank> ON<Cr> (<Lf>)

Interpretation:

PLOTS => plot status
 < > => encloses control characters
blank => blank character (this is essential)
CH1 => channel 1
ON => measured values are printed
 () => not essential
Cr/Lf => termination character

1 GENERAL NOTES

Note:

Any number of blank characters can be inserted before the code "PLOTS", the value "ON" and the termination character "Cr/Lf". The number of characters of a complete command must however not exceed 30.

Response of the JUMO LOGOPRINT C

OK<Cr>

Interpretation:

OK => value has been checked and entered

< > => encloses control characters

Cr => termination character

The following points apply in principle:

The commands may contain upper case or lower case letters.

Leading and (or) following zeroes in the parameters are permitted.

However the following restrictions apply:

The maximum number of characters in the parameter value is 6 characters (including sign and decimal point). If the string contains neither a sign nor a decimal point, it must only be 4 characters long. This automatically forms an upper limit to the value range.

While a command is being processed no further commands are accepted.

When commands and data have been understood and accepted, the response OK is transmitted.

Read-out

Generally not possible during initialisation (up to the end of the waiting phase) and after input of the code number "9200" (until leaving the parameter level) (Error 80).

Otherwise there are no restrictions on the parameters of the recorder, they can always be read. All additional read-outs, such as the group read-outs, are inhibited even after input of the code number from the interface (command: C9200 ON) through the appropriate error message, since the response cannot be defined uniquely in this condition. This is particularly essential in case of the process values. For details see the table on page 6.

Programming

Not possible during the initialisation phase (?Error 80), otherwise only in the base status.

Programming of a parameter via the serial interface is handled in the same way as programming via the keys. I.e.: in the case of a parameter of the parameter level (level P) or the configuration levels (levels C) the appropriate reactions are triggered (e.g. erasing all collected report data etc.). Use of the interface parameter "C9200" (ON/OFF) makes the connection to programming via the keys (Code 9200).

The effects produced by programming a parameter of (e.g.) the configuration level are retained until changeover is effected by "C9200 OFF", even when a parameter of the operator level (level S) has been programmed in the meantime via the serial interface.

Programming via the keys always has precedence over programming via the serial interface, i.e. entering the code number by the user resets the code number of the interface (corresponding to the command "C9200 OFF").

If the command "C9200 OFF" is transmitted when "C9200 ON" has been transmitted previously, the JUMO LOGOPRINT C moves into the waiting phase, the display shows "WAITING", as is known from operation.

During this period the operation is inhibited, the response to any command via the interface is "?Error 80". After the termination of the waiting phase, operation returns to the status in which it was previously, the display content is restored.

As indication that the JUMO LOGOPRINT C is in the configuration for the interface (C9200 ON) the LED of the display flashes at 5 Hz until C9200 OFF is recognised.

1 GENERAL NOTES

Programming examples

Example 1:

Programming a parameter of the operator level (level S).

Programming chart speed to 20 mm/h

FEEDP 20

Example 2:

Programming a parameter of the parameter level (level P).

Programming filter constant of channel 3 to 5.1

C9200 ON

FILT CH3 5.1

C9200 OFF

Example 3:

Programming several parameters of parameter level (level P) and configuration level (level C).

Programming filter constant of channel 1 to 5.1

Programming all settings for Ik1 and Ik2 channels 1 to 6

C9200 ON

FILT CH1 5.1

LIMR CH1 0.90

LIMR CH2 0 90

LIMR CH3 0 90

LIMR CH4 0 90

LIMR CH5 0 90

LIMR CH6 0 90

C9200 OFF

1.5 Codes for interface communication (see table on next page)

- x => channel number 1 to 6
- y => ext. contact 1 to 4
- r => can be read unless input takes place either during initialisation or when code number has been entered via the keys
- rc => can be read under conditions as „r“ and when no code number has been entered from the interface
- w => can be programmed

1 ALLGEMEINES

Kennwort	Bedeutung	r/w	Display
X CHx	Istwert Kanal x	rc	
ERR	Fehlermeldungen	rc	
AL	Alarm min/max	rc	
REL	Relaisstellungen Kl. 2, 3	rc	
DSW	Status	rc	
GR1	Gruppenabfrage Istwert CH1 ... 6	rc	
GR2	Gruppenabfrage ERR, AL, REL, DSW	rc	
VERS	Software-Version	r	
**** Bediener Ebene (S-Level) ****			
FEEDP	Papiervorschub	r/w	FEED.P
PLOTS CH x	Plotstatus Kanal x	r/w	PLOTSTAT
**** Parameterebene (P-Level) (CODE 9200) ****			
C9200	Programmierung P- und C-Level	r/w	
DATE	Datum	r/w	DATE
TIME	Uhrzeit	r/w	TIME
TIMEB	Beginn der Sommerzeit	r/w	S TIME B
TIMEE	Ende der Sommerzeit	r/w	S TIME E
PIEZO	Piezo-Summer	r	PIEZO
FILT CHx	Filterkonstante Kanal x	r/w	FILTER
**** Konfigurationsebene 1 (L1 Level) ****			
STATE CHx	Kanalstatus Kanal x	r	STATE
WORDN CHx	Kanalbezeichnung Kanal x	r	WORD+No
UNIT CHx	Größenordnung Kanal x	r	UNIT
Typ CHx	Meßbereiche Kanal x	r	TYP
DECDI CHx	Komma, Dimension, Kanal x	r	DEC/DIM
SCALE CHx	Skalierung Kanal x	r	SCALE.
LIMR CHx	Grenzwert für 1. Ik und 2. Ik Kanal x	r/w	LIM.R
REL1 CHx	Relais 1 ein/aus Kanal x	r	REL-1
REL2 CHx	Relais 2 ein/aus Kanal x	r	REL-2
LIMT1 CHx	Alarmtext, Relais 1 Kanal x	r	LIMTXT-1
LIMT2 CHx	Alarmtext, Relais 1 Kanal x	r	LIMTXT-2
LIMF CHx	Limitbereich für Vorschub Kanal x	r	LIMIT.F
PLOTA CHx	Darstellbereich Kanal x	r	PLOTAREA
OFFS CHx	Offsetbereich Kanal x	r	OFFSET
**** Konfigurationsebene 2 (C2 Level) ****			
UNITW	Gerätekennezeichnung	r	UNITWORD
BTXT	Beginntext	r	BEGINTXT
ETXT	Endetext	r	ENDTXT
REL1	Relais 1 Ik Auswahl	r	REL.F.1
REL2	Relais 2 Ik Auswahl	r	REL.F.2
FEEDL	Vorschub bei Limit	r	FEED.L
FEEDE	Vorschub bei ext. feet	r	FEED.E
FEEDT	Vorschub Zeitfenster	r	FEED.T
QUIT	Limit-Quittierung	r	QUIT
DREP	Daily Report	r	D REPORT
PREP	Measuring Period Report	r	M.P.R.
MREP	Message Report	r	M REPORT
EXTC CHy	Text für ext. Kontakt y	r	EXT.CO
COUNT CHy	Counter für externe Kontakte y	r	COUNTER
ECDIR	extern contact direction	r	ECDIR
Sonderfunktion:			
P	Drucken eines Text Reports	rc/w	

1 GENERAL NOTES

1.6 Error handling

After transmitting a command the master has to await the response of the slave. This time should be monitored using a time-out counter.

A fresh command can only be transmitted when the response has been received or when the time-out counter has counted down.

1.7 Error messages referring to a communication via the serial interface

?Error 80 = interface not active
?Error 81 = outside range of values
?Error 82 = parameter can only be read, cannot be programmed
?Error 83 = parameter does not exist in current configuration
?Error 85 = syntax error

1.8 Termination character

1.8.1 Termination character of the command

The termination character of the command (from the master) may be

<Cr> or
<Cr> <Lf> or
<Lf> <Cr>

The JUMO LOGOPRINT C recognises only <Cr> as termination character.

1.8.2 Termination character of response (from slave)

The termination character of the response is <Cr>.

1.9 Character set

ASCII 7-bit code

04 => <EOT> control character (Init)
10 => <LF> control character
13 => <CR> control character

1.9.1 Transmission from the LOGOPRINT to the master

To each special character is assigned an alternative character from the ASCII 7-bit code. Where this is not meaningful the character <#> is assigned.

The following numbering refers to the character set shown in the Operating Instructions (D 92.561, 1.91/V). The columns (first digit) are numbered 0 to 8. The lines (second digit) are numbered 0 to F.

character 05 => a
character 0C => u
character 12 => O
character 13 => A
character 14 => a
character 1D => 2

character 20 to 7E => <blank> to <">

character 81 => 3
character 82 => 2
character 83 => 3
character 84 => 0

1.9.2 Transmission from master to LOGOPRINT

Every character received is interpreted by the JUMO LOGOPRINT C as ASCII 7-bit code.

1.9.3 Arrangement of the software

The software for serial communication consists of:

- input/output driver
- processing of the commands/responses

The input/output driver is interrupt-controlled and processes one character at a time. With the code "input/output buffer full/empty" it transfers a complete command at a time or accepts a response from the processing program.

The processing program is called up at constant time intervals; it decodes and tests the command, executes it and prepares the appropriate response.

2 SYNTAX OF ALL COMMANDS AND POSSIBLE RESPONSES

For clearer presentation the control characters are omitted. Each line represents a possible response.

In the following text, bits are counted from right to left starting with "bit0", and groups are counted from left to right starting with "position 1".

2.1 Process value

Read-out of the parameter

?X CH1

Possible responses of the JUMO LOGOPRINT C, e.g.:

+0.198
+****
<-019.8
>-019.8
<<<<<<<<
>>>>>>>
?Error 80
?Error 83
?Error 85

Interpretation:

< value => underrange (software)
> value => overrange (software)
<<<<<<<< => underrange (hardware)
>>>>>>> => overrange (hardware)

Programming the parameter

X CH1 5
X CH1 5.
X CH1 5.0
X CH1 5.00
X CH1 5.000
X CH1 +5
X CH1 +5.
X CH1 +5.0
X CH1 +5.00
X CH1 +5.000
X CH1 05
X CH1 005
etc.

2.2 Error message

Read-out of the parameter

?ERR

Possible responses of the LOGOPRINT C

0000
?Error 80
?Error 82
?Error 83
?Error 85

Interpretation (from right to left)

bit 0 => low battery
bit 1 => paper end
bit 2 => EEPROM fault
bit 3 => not used

0 => no fault
1 => fault

here:

no fault

Error messages cannot be programmed.

2.3 Alarm

Read-out of the parameter

?AL

Possible responses of the JUMO LOGOPRINT C

100110000101
?Error 80
?Error 82
?Error 83 (if no channel is active)
?Error 85

Interpretation (from right to left)

bit 0=> Ch1 high alarm
bit 1=> Ch1 low alarm

bit 2=> Ch2 high alarm
bit 3=> Ch2 low alarm

bit 4=> Ch3 high alarm
bit 5=> Ch3 low alarm

bit 6=> Ch4 high alarm
bit 7=> Ch4 low alarm

bit 8=> Ch5 high alarm
bit 9=> Ch5 low alarm

bit 10 => Ch6 high alarm
bit 11 => Ch6 low alarm

0 => no alarm
1 => alarm

here:

Ch1 high alarm

Ch2 high alarm

Ch3 no alarm

Ch4 high alarm

Ch5 high alarm

Ch6 low alarm

Alarms cannot be programmed.

Note:

Channels which are configured inactive are represented in the bit combination as "00".

2 SYNTAX ALLER ANWEISUNGEN UND ANTWORTMÖGLICHKEITEN

2.4 Relaisstellungen

Lesen des Parameters

?REL

Mögliche Antworten des JUMO LOGOPRINT C

001

?Error 80

?Error 82

?Error 83

?Error 85

Bedeutung (von rechts nach links)

Bit 0 => Kontakt 1 (Limit-Komparator)

Bit 1 => Kontakt 2 (Limit-Komparator)

Bit 2 => Kontakt 3 (Störung)

0 => Kontakt aktiv

1 => Kontakt inaktiv

hier:

Kontakt 1 aktiv

Kontakt 2 inaktiv

Kontakt 3 inaktiv

Relaisstellungen sind nicht programmierbar.

2.5 Status (Device Status Word)

Lesen des Parameters

?DSW

Mögliche Antworten des JUMO LOGOPRINT C

000000001100001 14

?Error 80

?Error 82

?Error 83

?Error 85

Bedeutung (von rechts nach links)

Position 1 => 15stellige Bitkombination
zur Darstellung „anstehender“
Ereignisse (von rechts nach
links)

Bit 0 => Feed Paper

Bit 1 => Feed Time

Bit 2 => Feed Extern

Bit 3 => Feed Limit

Bit 4 => Measuring Period Report

Bit 5 => Daily Report

Bit 6 => Message Report

Bit 7 => Text Report

Bit 8 => Programm Parameter

Bit 9 => Service Print

Bit 10 => Printtest

Bit 11 => Codenummer (bzw. C9200) Stop

Bit 12 => kein Papier Stop

Bit 13 => extern Stop

Bit 14 => Taste Stop

Position 17 => zweistellige Ziffer zur
Darstellung „aktives“ Ereignis

00 => Feed Paper

01 => Feed Time

02 => Feed Extern

03 => Feed Limit

04 => Measuring Period Report

05 => Daily Report

06 => Message Report

07 => Text Report

08 => Programm Parameter

09 => Service Print

10 => Printtest

11 => Codenummer (bzw. C9200) Stop

12 => kein Papier Stop

13 => extern Stop

14 => Taste Stop

hier:

Daily Report und Message Report stehen an, können aber nicht gedruckt werden, da Taste „Stop“ aktiv ist.

Anmerkung:

Bit-11 wird immer 0, da das DSW nach Eingabe der Codenummer nicht abgefragt werden kann (?Error 80). Wird hier nur aufgenommen, damit alle Prioritätsstufen erkennbar sind. Der Status ist nicht programmierbar.

2 SYNTAX ALLER ANWEISUNGEN UND ANTWORTMÖGLICHKEITEN

2.6 Gruppenabfrage

Gruppenabfrage 1
Lesen des Parameters
?GR1

1+123.1 2+100.0 3 < -050.0 4 >>>>>>>
5-010.8 6-010.9
1+123.1 2+100.0 4 >>>>>>> 5+***

... usw. je nach Konfiguration

?Error 80
?Error 82
?Error 83
?Error 85

Bedeutung

Istwerte je nach Konfiguration (keine festen Positionen).

Die Gruppenabfrage 1 ist nicht programmierbar.

Gruppenabfrage 2
Lesen des Parameters
?GR2

Mögliche Antworten des JUMO LOGOPRINT C
0000 100110000101 001 000000001100001 14
?Error 80
?Error 82
?Error 83
?Error 85

Bedeutung (von links nach rechts)

Position 1 => Fehlermeldungen
Position 6 => Alarme
Position 19 => Relaisstellungen
Position 33 => Status

Bedeutung der Bitkombinationen:

siehe unter Fehlermeldungen, Alarme, Relaisstellungen, Status

Die Gruppenabfrage 2 ist nicht programmierbar.

2.7 Papiervorschub

Lesen des Parameters
?FEEDP

Mögliche Antworten des JUMO LOGOPRINT C
120
240
... usw.

?Error 80
?Error 83
?Error 85

Bedeutung

5 => 5 mm/h

Programmieren des Parameters
FEEDP 5

Mögliche Antworten des JUMO LOGOPRINT C
OK
?Error 80
?Error 85

2.8 Plotstatus

Lesen des Parameters
?PLOTS CH1

Mögliche Antworten des JUMO LOGOPRINT C
ON
OFFP
?Error 80
?Error 83
?Error 85

Programmieren des Parameters
PLOTS CH1 ON
PLOTS CH1 OFFP

Mögliche Antworten des JUMO LOGOPRINT C
OK
?Error 80
?Error 85

2.9 Programmierung P- und C-Level

Lesen des Parameters
?C9200

Mögliche Antworten des JUMO LOGOPRINT C
ON
OFF
?Error 80
?Error 85

Programmieren des Parameters
C9200 ON
C9200 OFF

Mögliche Antworten des JUMO LOGOPRINT C
OK
?Error 80
?Error 85

2.10 Datum

Lesen des Parameters
?DATE

Mögliche Antworten des JUMO LOGOPRINT C
31.12.90
?Error 80
?Error 85

Programmieren des Parameters
DATE 31.12.90

Mögliche Antworten des JUMO LOGOPRINT C
OK
?Error 80
?Error 85

2 SYNTAX OF ALL COMMANDS AND POSSIBLE RESPONSES

2.11 Time

Read-out of the parameter

?TIME

Possible responses of the JUMO LOGOPRINT C

13:59

?Error 80

?Error 85

Programming the parameter

TIME 13:59

Possible responses of the JUMO LOGOPRINT C

OK

?Error 80

?Error 83

?Error 85

2.12 Summer time

Beginning of summer time

Read-out of the parameter

?TIMEB

Possible responses of the JUMO LOGOPRINT C

26.03.90 02:00

?Error 80

?Error 85

Interpretation

position 1 => date

position 10 => time

Programming the parameter

TIMEB 26.03.90 02:00

Possible responses of the JUMO LOGOPRINT C

OK

?Error 80

?Error 83

?Error 85

End of summer time

Read-out of the parameter

?TIMEE

Possible responses of the JUMO LOGOPRINT C

24.09.90 03:00

?Error 80

?Error 85

Interpretation

position 1 => date

position 10 => time

Programming the parameter

TIMEE 24.09.90 03:00

Possible responses of the JUMO LOGOPRINT C

OK

?Error 80

?Error 83

?Error 85

2.13 Piezo beeper

Read-out of the parameter

?PIEZO

Possible responses of the JUMO LOGOPRINT C

ON

OFF

?Error 80

?Error 82

?Error 85

The piezo beeper cannot be programmed.

2.14 Filter constant

Read-out of the parameter

?FILT CH1

Possible responses of the JUMO LOGOPRINT C

+005.4

?Error 80

?Error 83

?Error 85

Programming the parameter

FILT CH1 5.4

Possible responses of the JUMO LOGOPRINT C

OK

?Error 80

?Error 81

?Error 83

?Error 85

2.15 Channel status

Read-out of the parameter

?STATE CH1

Possible responses of the JUMO LOGOPRINT C

ON

OFF

?Error 80

?Error 82

?Error 83

?Error 85

The channel status cannot be programmed.

2.16 Channel designation

Read-out of the parameter

?WORDN CH1

Possible responses of the JUMO LOGOPRINT C

'boiler pressure'

?Error 80

?Error 82

?Error 83

?Error 85

The channel designation cannot be programmed.

2 SYNTAX OF ALL COMMANDS AND POSSIBLE RESPONSES

2.17 Ranges

Read-out of the parameter

?TYP CH1

Possible responses of the JUMO LOGOPRINT C 200

CURRENT +000.0 +020.0 LINEAR

CURRENT +000.0 +020.0 TypeL
TempC -200.0 +900.0

VOLTAGE +000.0 +010.0 LINEAR

VOLTAGE +000.0 +010.0 TypeL
TempC -200.0 +900.0

T-COUPLE TypeL TempF -0200. +0900.
EXTERNAL +0030.

RTD Pt100 TempC -0200. +0900.

POTENT. +0000. +0001.

R.TRANS. +0000. +0001. +0040.

?Error 80

?Error 82

?Error 83

?Error 85

Interpretation of response 1 (left to right):

position 1 => CURRENT
position 9 => Iz
position 16 => If
position 23 => linearisation

Interpretation of response 2 (left to right):

position 1 => CURRENT
position 9 => Iz
position 16 => If
position 23 => linearisation
position 29 => degree Celsius
position 35 => Tz
position 42 => Tf

Interpretation of response 3 (left to right):

position 1 => VOLTAGE
position 9 => Uz
position 16 => Uf
position 23 => linearisation

Interpretation of response 4 (left to right):

position 1 => VOLTAGE
position 9 => Uz
position 16 => Uf
position 23 => linearisation
position 29 => degree Celsius
position 35 => Tz
position 42 => Tf

Interpretation of response 5 (left to right):

position 1 => T-COUPLE (thermocouple)
position 10 => Linearisation
position 16 => degree Fahrenheit
position 22 => Tz
position 29 => Tf
position 36 => ambient temperature compensation
position 45 => cold junction temperature

Interpretation of response 6 (left to right):

position 1 => RTD (resistance thermometer)
position 5 => Linearisation
position 11 => degree Celsius
position 17 => Tz
position 24 => Tf

Interpretation of response 7 (left to right)

position 1 => POTENT. (potentiometer)
position 9 => start resistance
position 16 => slider resistance

Interpretation of response 8 (left to right)

position 1 => RTRANS (resistance transmitter)
position 10 => start resistance
position 17 => slider resistance
position 24 => end resistance

Possible responses of the JUMO LOGOPRINT C 240:

0...20 mA
4...20 mA
0... 1 V
0...10 V

The ranges cannot be programmed.

2.18 Decimal place, unit

Read-out of the parameter

?DEC DI CH1

Possible responses of the JUMO LOGOPRINT C

XX.XX 'mm/min'
AUTOM. 'mm/min'
?Error 80
?Error 82
?Error 83
?Error 85

Interpretation (from left to right)

position 1 => resolution of indication
position 7 => unit

The decimal places and the unit cannot be programmed

2 SYNTAX ALLER ANWEISUNGEN UND ANTWORTMÖGLICHKEITEN

2.19 Skalierung

Lesen des Parameters

?SCALE CH1

Mögliche Antworten des JUMO LOGOPRINT C

-100.0 +100.0

?Error 80

?Error 82

?Error 83

?Error 85

Bedeutung (von links nach rechts)

-100.0 +100.0

?Error 80

?Error 82

?Error 83

?Error 85

Bedeutung (von links nach rechts)

Position 1 => Scale Zero

Position 8 => Scale Full

Die Skalierung ist nicht programmierbar.

2.20 Grenzwert für 1. und 2. Ik

Lesen des Parameters

?LIMR CH1

Mögliche Antworten des JUMO LOGOPRINT C

-005.0 +100.0

?Error 80

?Error 83

?Error 85

Programmieren des Parameters

LIMR CH1 5.0 +100.0

Mögliche Antworten des JUMO LOGOPRINT C

OK

?Error 80

?Error 81

?Error 83

?Error 85

2.21 Relais ein/aus

Relais1 ein/aus

Lesen des Parameters

?REL1 CH1

Mögliche Antworten des JUMO LOGOPRINT C

ON

OFF

?Error 80

?Error 82

?Error 83

?Error 85

Das Relais1 ist nicht programmierbar.

Relais2 ein/aus

Lesen des Parameters

?REL2 CH1

Mögliche Antworten des JUMO LOGOPRINT C

ON

OFF

?Error 80

?Error 82

?Error 83

?Error 85

Das Relais2 ist nicht programmierbar.

2.22 Alarmtext Relais

Alarmtext Relais1

Lesen des Parameters

?LIMT1 CH1

Mögliche Antworten des JUMO LOGOPRINT C

'Grenzwert unten'

?Error 80

?Error 82

?Error 83

?Error 85

Der Alarmtext ist nicht programmierbar.

Alarmtext Relais2

Lesen des Parameters

?LIMT2 CH1

Mögliche Antworten des JUMO LOGOPRINT C

"Grenzwert oben"

?Error 80

?Error 82

?Error 83

?Error 85

Der Alarmtext ist nicht programmierbar.

2.23 Limitbereich für Vorschub

Lesen des Parameters

?LIMF CH1

Mögliche Antworten des JUMO LOGOPRINT C

-000.1 +100.0

?Error 80

?Error 82

?Error 83

?Error 85

Bedeutung (von links nach rechts)

Position 1 => Limit unten

Position 8 => Limit oben

Der Limitbereich ist nicht programmierbar.

2 SYNTAX OF ALL COMMANDS AND POSSIBLE RESPONSES

2.24 Plotting range (PLOTAREA)

Read-out of the parameter

?PLOTAREA CH1

Possible responses of the JUMO LOGOPRINT C

+000.0 +100.0

?Error 80

?Error 82

?Error 83

?Error 85

Interpretation (left to right)

position 1 => range bottom 0%

position 8 => range top 100%

The plotting range cannot be programmed.

2.25 Offset range

Read-out of the parameter

?OFFS CH1

Possible responses of the JUMO LOGOPRINT C

+000.0 +100.0

?Error 80

?Error 82

?Error 83

?Error 85

Interpretation (left to right)

position 1 => range bottom 0%

position 8 => range top 100%

The offset range cannot be programmed.

2.26 Instrument designation

Read-out of the parameter

?UNITW

Possible responses of the JUMO LOGOPRINT C

'Plant 28'

?Error 80

?Error 82

?Error 85

The instrument designation cannot be programmed.

2.27 Beginning text

Read-out of the parameter

?BTXT

Possible responses of the JUMO LOGOPRINT C

'****Start****'

?Error 80

?Error 82

?Error 85

The beginning text cannot be programmed.

2.28 End text

Read-out of the parameter

?ETXT

Possible responses of the JUMO LOGOPRINT C

'****End****'

?Error 80

?Error 82

?Error 85

The end text cannot be programmed.

2.29 Relay Ik selection

Relay 1 Ik selection

Read-out of the parameter

?REL1

Possible responses of the JUMO LOGOPRINT C

Ik7

?Error 80

?Error 82

?Error 85

The Ik selection of the relay cannot be programmed.

Relay 2 Ik selection

Read-out of the parameter

?REL2

Possible responses of the JUMO LOGOPRINT C

Ik8

?Error 80

?Error 82

?Error 85

The Ik selection of the relay cannot be programmed.

2.30 Chart speed

2.30.1 Chart speed at FEED LIMIT

Read-out of the parameter

?FEEDL

Possible responses of the JUMO LOGOPRINT C

720

?Error 80

?Error 82

?Error 85

Interpretation

720 => 720 mm/h

The chart speed on out-of-limit cannot be programmed.

2 SYNTAX OF ALL COMMANDS AND POSSIBLE RESPONSES

2.30.2 Chart speed at FEED EXTERN

Read-out of the parameter

?FEEDE

Possible responses of the JUMO LOGOPRINT C

720

?Error 80

?Error 82

?Error 85

Interpretation

720 => 720 mm/h

The chart speed on FEED EXTERN cannot be programmed.

2.30.3 Chart speed at FEED TIME

Read-out of the parameter

?FEEDT

Possible responses of the JUMO LOGOPRINT C

720 12:35 15:45

?Error 80

?Error 82

?Error 85

Interpretation

position 1 => chart speed

position 5 => time from

position 11 => time to

The chart speed in the time window cannot be programmed.

2.31 Limit acknowledgment

Read-out of the parameter

?QUIT

Possible responses of the JUMO LOGOPRINT C

YES

NO

?Error 80

?Error 82

?Error 85

The limit acknowledgment cannot be programmed.

2.32 Reports

2.32.1 Daily report

Read-out of the parameter

?DREP

Possible responses of the JUMO LOGOPRINT C

ON 02:00

OFF

?Error 80

?Error 82

?Error 85

Interpretation

ON 02:00 => the daily report always takes place at 02.00 hours

OFF => (print-out of) daily report switched off

The daily report cannot be programmed.

2.32.2 Measuring period report

Read-out of the parameter

?PREP

Possible responses of the JUMO LOGOPRINT C

2

OFF

?Error 80

?Error 82

?Error 85

Interpretation

2 => the measuring period report takes place every 2 hours

OFF => (print-out of) measuring period report switched off

The measuring period report cannot be programmed.

2.32.3 Message report

Read-out of the parameter

?MREP

Possible responses of the JUMO LOGOPRINT C

2

OFF

?Error 80

?Error 82

?Error 85

Interpretation

2 => the message report takes place every 2 hours

OFF => message report switched off

The message report cannot be programmed.

2.33 Text for external contact

Read-out of the parameter

?EXTC CHy for y = 1 to 4

Possible responses of the JUMO LOGOPRINT C

'Furnace open'

?Error 80

?Error 82

?Error 85

The text for external contact cannot be programmed.

2.34 Counter (for external contact)

Read-out of the parameter

?COUNT CHy for y = 1 to 4

Possible responses of the JUMO LOGOPRINT C

ON 1289

OFF

?Error 80

?Error 82

?Error 85

The parameter cannot be programmed.

2 SYNTAX OF ALL COMMANDS AND POSSIBLE RESPONSES

2.35 EC DIR

Read-out of the parameter

?ECDIR

Possible responses of the JUMO LOGOPRINT C

MREP + PAP

MREP

?Error 80

?Error 82

?Error 85

The parameter cannot be programmed.

Printing of a text is treated as a "text report" and is comparable with the execution of the daily report, the message report and the measuring period report.

Print presentation:

'<----- 36 characters ----->'

COMM12:49|20.04.90|process 1 start

Colours (from left to right)

from position 1 => violet

from position 6 => red

from position 21 => alternating

Priorities

Event	Priority
Feed paper	0 (low)
Feed time	1
Feed external	2
Feed limit	3
Measuring period report	4
Daily report	5
Message report	6
Text report	
(interface instruction)	7
Program parameter	8
Service print	9
Printtest	10
Code number stop	11
No-paper stop	12
External stop	13
Stop key	14

2.36 Print-out of a text report

Read-out of the parameter

?P

Possible responses of the JUMO LOGOPRINT C

BUSY

READY

?Error 80

?Error 85

Interpretation

BUSY => text buffer is full, a text cannot be accepted at present

READY => text buffer is empty, i.e. a P command (if existing) has been completely (!) executed

Programming the parameter

P 'process 1 start'

Note:

The text is marked with single quotation marks. The text may contain up to 16 characters. The text is accepted only if the text buffer is empty.

Possible responses of the JUMO LOGOPRINT C

OK

BUSY

?Error 80

?Error 81

?Error 85

Interpretation

OK => the text is entered into the text buffer and is being processed in accordance with the priority schedule

BUSY => the text buffer is full, the text cannot be entered at present

3 SPECIAL FEATURES OF THE INTERFACES

3.1 Interface RS232

Processing a command

Processing in the JUMO LOGOPRINT C is initiated by:
sending of the <Cr> or overflow of the input buffer
(size of the input buffer: 99 characters).

Overflow of the input buffer results in the message:

?Error 85 <Cr>

Interpretation

?Error 85 => syntax error

< > => encloses control character

Cr => termination character

3.1.1 Interface operation without handshake

Communication takes place via RxD, TxD, ground. RTS and CTS remain open-circuit (do not link them together). If additional characters are transmitted to the JUMO LOGOPRINT C during processing of an interface command, up to two characters can be saved. All additional characters are lost. These 2 characters max. are interpreted as the start of the next command.

3.1.2 Interface operation with handshake

Communication takes place via TxD, RxD, RTS, CTS, ground. After recognition of a command, RTS is switched inactive and the other device is thereby inhibited. Only up to 2 characters can then be saved during processing of the command. These 2 characters max. are interpreted as the start of the next command.

The response is only output when the other device permits this through CTS. If CTS is inhibited, the JUMO LOGOPRINT C attempts for 20 seconds to transmit this message which is stored in its internal output buffer (then the response is cancelled => time-out).

This function is provided to prevent transmitting a process value which is then no longer current, e.g. if the transmission path is blocked by the other device for a longer period.

After transmitting or cancelling the response the RTS again becomes active.

3.2 Interfaces RS422/485

A master-slave concept is realised which permits a host master computer to address several slaves via a bus. Up to 32 devices (including the master) can be connected to this bus.

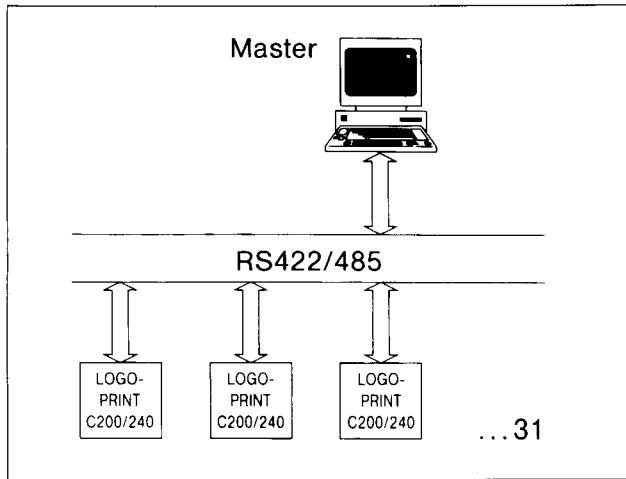

RS422

Communication via a pair of wires for transmitting and a pair of wires for receiving, ground.

RS485

Communication via a pair of wires for transmitting/receiving, ground.

3.2.1 Differences in the commands compared with RS232

The same code words are used for the commands as on the RS232. The difference is the additional device address which precedes each command as a separate command (separated by blank).

e.g.:

*11<blank>FEEDP<blank>5<Cr>(<Lf>)

Interpretation

* => code RS422/485

11 => device number

FEEDP => chart speed

blank => blank character

5 => chart speed 5 mm/h

() => no meaning

Cr/Lf = termination characters

Sales Offices and Service Stations – Germany

Berlin

Heinz Konsolke
Bismarckstrasse 16 d-e
D-12169 Berlin
Phone (0 30) 7 95 30 21
Telefax (0 30) 7 95 30 25
Telex 1 82 997

Darmstadt

M. K. Juchheim GmbH & Co.
Niederlassung Darmstadt
Weiterstädter Strasse 135
D-64291 Darmstadt-Arheilgen
Phone (0 61 51) 35 08-0
Telefax (0 61 51) 35 08 81
Manager: Wolfgang Vogl

Erfurt

M. K. Juchheim GmbH & Co.
Außenbüro Erfurt
Friedrich-Engels-Straße 12
D-99334 Ichtshausen
Phone (0 36 28) 7 57 63
Telefax (0 36 28) 7 57 63
Manager: Bernd Westerhoff

Essen

M. K. Juchheim GmbH & Co.
Niederlassung Essen
P. O. Box 11 03 65
D-45333 Essen
Phone (02 01) 66 30 71-74
Telefax (02 01) 66 87 80
Manager: Lothar Bläser

Giessen

M. K. Juchheim GmbH & Co.
Niederlassung Giessen
P. O. Box 11 08
D-35441 Biebertal
Phone (0 64 09) 81 00-0
Telefax (0 64 09) 81 00-49
Manager: Ingo Skrzypczyk

Hamburg

M. K. Juchheim GmbH & Co.
Aussenbüro Hamburg
Horstweg 20
D-22391 Hamburg
Phone (0 40) 6 01 77 55-56
Telefax (0 40) 6 01 07 34
Manager: Ing. grad. H. Schirner

Hannover

M. K. Juchheim GmbH & Co.
Niederlassung Hannover
Gehrenbreite 2
D-31542 Bad Nenndorf
Phone (0 57 23) 50 47-49
Telefax (0 57 23) 7 54 11
Manager: Dipl.-Ing. G. Werwitzke

Cologne

M. K. Juchheim GmbH & Co.
Aussenbüro Köln
Bonner Ring 17a
D-50374 Erftstadt-Lechenich
Phone (0 22 35) 50 71
Telefax (0 22 35) 7 13 07
Manager: D. Grosskinsky

Leipzig

M. K. Juchheim GmbH & Co.
Außenbüro Leipzig
Gustav-Adolf-Straße 38
D-04105 Leipzig
Phone (03 41) 28 52 81
Telefax (03 41) 28 52 81
Manager: Hans-Jürgen Paul

Austria

JUMO Mess- u. Regelgeräte Ges.m.b.H.
Pfarrgasse 48, A-1232 Wien
Phone (02 22) 67 95 33-0
Telefax (02 22) 67 95 33 59, Telex 13-30 76

Belgium

JUMO AUTOMATION
S.P.R.L./P.G.M.B.H./B.V.B.A.
Industriestrasse 18, B-4700 EUPEN
Phone (087) 740 440
Telefax (087) 740 203
Telex 49 067 (JUMO B)

Denmark

JUMO Måle- og Reguleringssteknik A/S
Fabriksvænget 16, Postboks 80
DK-4130 Viby Sj
Phone (0 42) 39 30 06
Telefax (0 42) 39 43 63

France

JUMO Régulation S.A., Actipôle Borny
7, rue des drapiers, B. P. 5200
F-57075 Metz-Cedex 3
Phone 87.37.53.00, Telefax 87.74.20.92
Telex 930.464

Italy

JUMO Italia s.r.l.
Piazza Esquilino 5, I-20148 Milano
Phone (02) 4 04 84 40
Telefax (02) 4 07 81 05

Netherlands

JUMO Meet- en Regeltechniek B. V.
Postbus 115, NL-1380AC Weesp
Phone (0 29 40) 90 76/1 39 91
Telefax (0 29 40) 1 95 77

Representatives in:

Argentina, Brazilia, Canada, Chile, Czech Republic, Finland, Greece, Hungary, India, Indonesia, Iran, Republic of Ireland, Israel, Norway, Portugal, Singapore, Slovakian Republic, Venezuela, Yugoslavia

Magdeburg

M. K. Juchheim GmbH & Co.
Außenbüro Magdeburg
Parzellenweg 1a
D-39130 Magdeburg
Phone (03 91) 5 61 44 06
Telefax (03 91) 5 61 44 06
Manager: Frank Sperling

Munich

M. K. Juchheim GmbH & Co.
Aussenbüro München
Himmelreichweg 23
D-85221 Dachau
Phone (0 81 31) 8 32 40
Telefax (0 81 31) 8 22 69
Manager: W. Neuwert

Nürnberg

M. K. Juchheim GmbH & Co.
Aussenbüro Nürnberg
Schäferweg 3
D-91233 Neunkirchen am Sand
Phone (0 91 23) 1 45 46
Telefax (0 91 23) 8 26 73
Manager: Erwin Kolb

Stuttgart

M. K. Juchheim GmbH & Co.
Niederlassung Stuttgart
P. O. Box 12 45
D-73220 Kirchheim unter Teck
Phone (0 70 21) 8 20 11
Telefax (0 70 21) 5 95 05
Telex 7 267 708
Manager: Ing. grad. R. Geier

Europe and USA

Russia

JUMO Meß- und Regeltechnik AG
Krasnopresnenskay Nab., D. 1/2, Kv. 132
RF-123 376 Moskau
Phone (0 95) 2 05 06 71
Telefax (0 95) 2 05 06 71
Telex 411700 (for JUMO S)

Spain

JUMO SERCON S.A.
Taquiraf Garriga, 44
E-08014 Barcelona
Phone (03) 4 10 94 92
Telefax (03) 4 19 64 31

Sweden

JUMO Mät- och Reglerteknik AB
Karbingatan 32, Box 22073
S-250 22 Helsingborg
Phone 0 42-12 36 60
Telefax 0 42-20 16 15, Telex 72 058 jutex S

Switzerland

JUMO Mess- & Regeltechnik AG
Seestr. 67, CH-8712 Stäfa
Phone (01) 9 28 21 41
Telefax (01) 9 26 67 65

United Kingdom

JUMO Instrument Co. Ltd.
Temple Bank, Riverway
Harlow, Essex CM20 2TT
Phone (02 79) 63 55 33
Telefax (02 79) 63 52 62

USA

JUMO PROCESS CONTROL INC.
735 Fox Chase, Coatesville, PA 19320
Phone 215-380-8002, 800-554-Jumo
Telefax 215-380-8009