

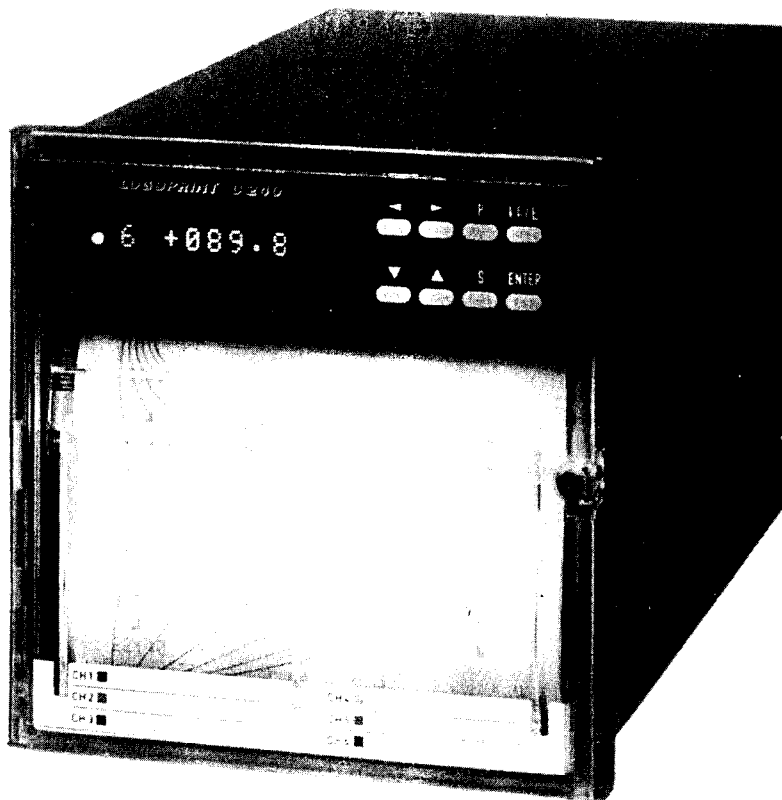

MEASUREMENT AND CONTROL

LOGOPRINT® C 240

6-colour Printing Recorder with isolated analogue inputs



B 95.4016

1.95 / V 00074025

Operating Instructions

OPERATING NOTES / PROGRAMMING

KEY FUNCTIONS

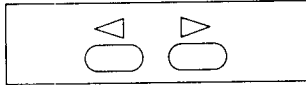

- Digit selection keys "left" and "right" when inputting/altering alphanumerical values

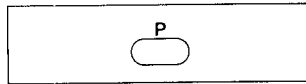

- Print program parameters
- Alter decimal place
- Quick selection for text input

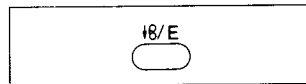

- Fast forward chart speed (after key)
- Stepwise exit from levels
- Abort editing

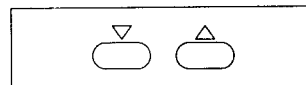

- Decrement/increment
- Input data
- Fast scrolling of values/parameters

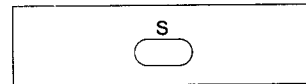

- Stop recording

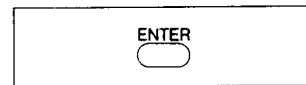

- Initiate editing
 - Enter values
 - Switching between cyclic and static indication in base status
- No alarm messages are indicated during static indication**

LED

steady:
recording interrupted
(key depressed)

flashing:
chart used up

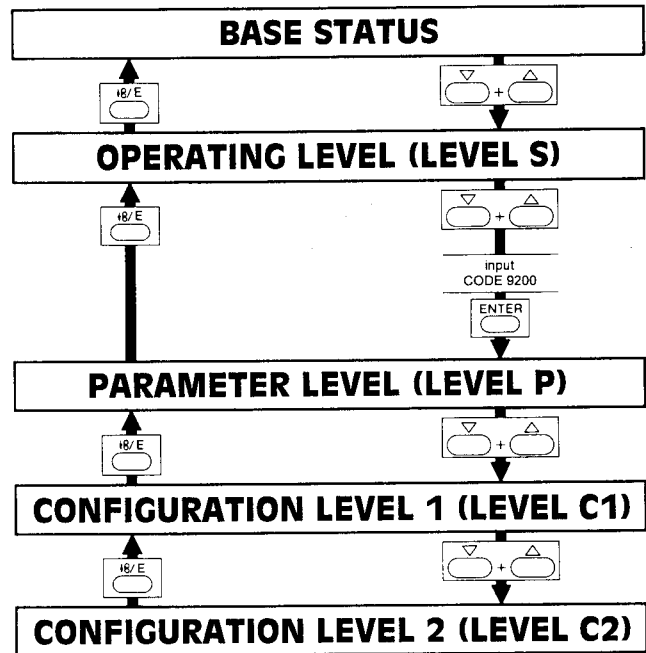

At all levels shown above the parameter selection is made following the same procedure:

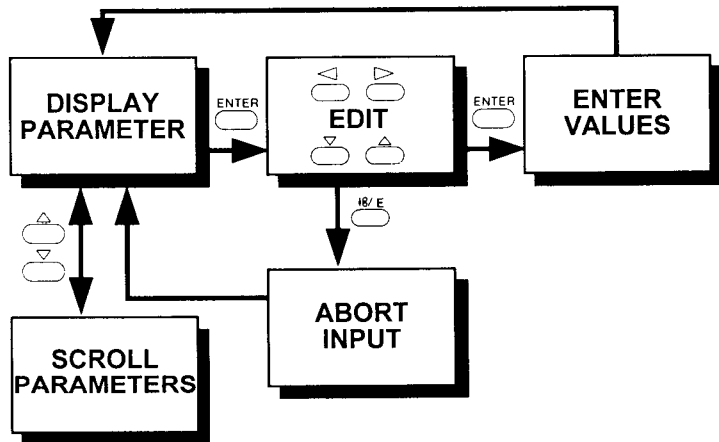

CHARACTER SET

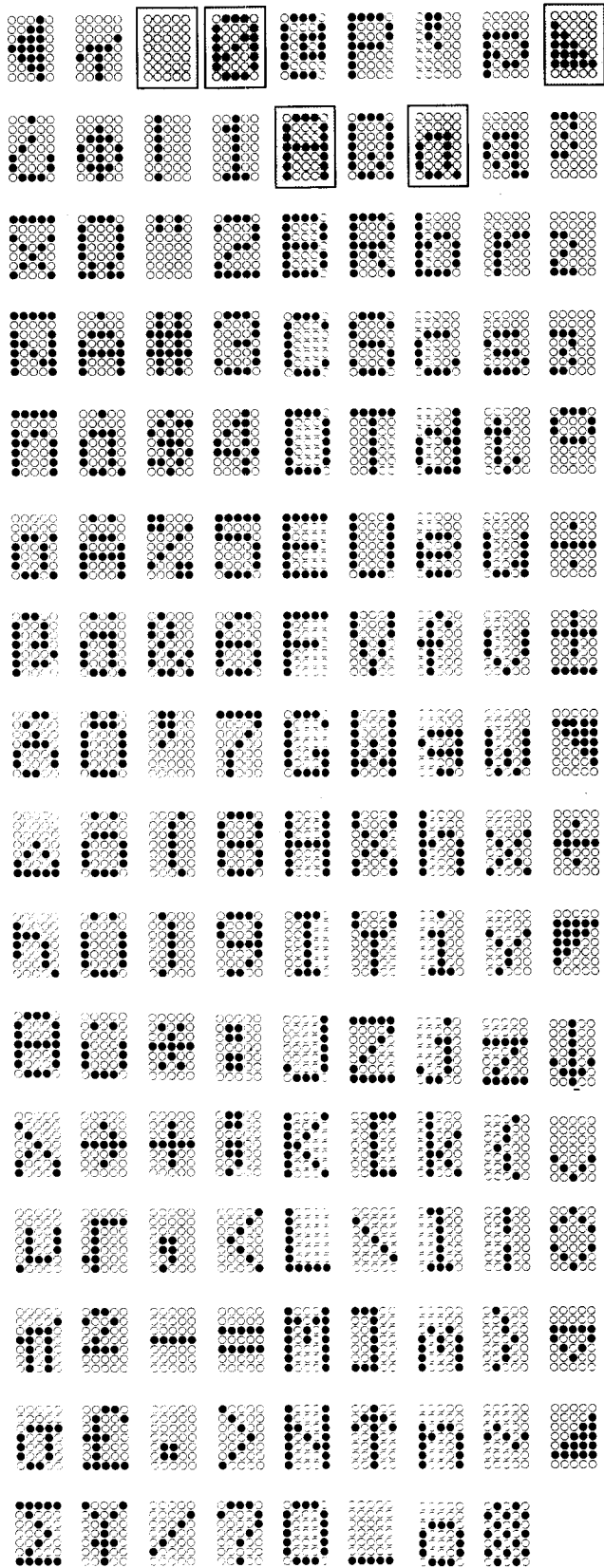

Access symbol
for
quick selection
with key



CONTENTS

	Page
1 DESCRIPTION	1
1.1 Type designation	1
1.2 Extra Codes	1
1.3 Standard accessories	1
1.4 Consumables	1
1.5 Design features	2
2 TECHNICAL DATA	3
2.1 Printing recorder for transducers with standard signal	3
2.2 General data	3
2.3 Block diagram	6
2.4 Operation	6
2.5 Dimensions	7
3 INSTALLATION	8
3.1 Location and climatic conditions	8
3.2 Important notes	8
3.3 Fitting in position	8
3.4 Electrical connection	9
3.4.1 Connection diagram	9
4 OPERATION	10
4.1 Operating modes	10
4.1.1 General notes on recording	10
4.1.2 Print-out modes	13
4.2 Preparation	16
4.2.1 Checking the supply voltage	16
4.2.2 Opening the housing door	16
4.2.3 Marking the channel label	16
4.2.4 Fitting the print head	17
4.2.5 Connection of the external operating inputs (example)	17
4.2.6 Removing the chart cassette and chassis	17
4.2.7 Changing the ranges	18
4.2.8 Supply for the operating inputs	18
4.3 Operation/programming	19
4.4 Removing the chart	24
4.5 Fitting the memory card	24
5 CHANGING CONSUMABLES	25
5.1 Changing the chart roll	25
5.2 Changing the fanfold chart	26
5.3 Replacing the print head	27
6 FAULT FINDING	28
6.1 Check the mains fuse, replace if required	28
6.2 No recording	28
6.3 Faulty recording	28

NOTE:

All necessary settings and, where appropriate, alterations are described in these Operating Instructions. If, however, any difficulties should arise during start-up, you are asked not to carry out any manipulation on the instrument which is not permitted. – You could endanger your rights under the instrument warranty.

Please contact the nearest office or the main factory.

For repair or servicing please do not ship the chassis without the housing. If this is not possible, the chassis or the individual electronic module must be protected by electrically conducting foil.

1 DESCRIPTION

6-colour graphic and alphanumerical recording as well as an alphanumerical display are the special features of this microprocessor-controlled printing recorder. Printing of 6 values and the corresponding text requires 4 sec per print line.

The chart is blank and is printed simultaneously with graduation and time marks, the channel designation, scaling, date and time.

The keys, the 8-character alphanumerical LED display and the LED for recording stop or chart end are located on the fascia. Limit contacts can be set.

A version for flush panel mounting and two portable models are available.

1.1 Type designation

LD6v-44/4

LD	Printing recorder
6	6 analogue inputs
v	amplifier
-44	bezel 144 x 144 mm
/4	instrument type 4
	input for current and voltage

1.2 Extra Codes

RS232C	serial data interface
RS422/485	serial data interface
mc	memory card with appropriate software
fp	fanfold chart cassette for fanfold chart 16 m long
gk	closed circuit when chassis is removed from the housing. When using gk resistors the recorder can only be used for current inputs!
as	chart run-out slot in housing door
ab	housing for wall mounting. The panel-mounting housing is fitted in a carrier and can be swung out through 90°.
tm	housing with carrying handle, rubber feet and terminal cover, also 3 m mains cable with grounded plug
TRS-36	portable recording station, completely wired, for varying applications in mobile use and for monitoring process variables

1.3 Standard accessories

- 2 Mounting brackets
- 2 Keys for housing door
- 1 Chart roll
- 1 Operating Instructions
- 1 Print head

1.4 Consumables

- Chart roll, 16 m long, paper thickness 47 µm, Ref. No. 67 040
- Fanfold chart, 16 m long, Ref. No. 83 781
- Print head (6 colours), Ref. No. 67 037
- Memory card, Ref. No. 67 775

1 DESCRIPTION

1.5 Design features

- ① Alphanumeric LED display
- ② LED
- ③ Chart
- ④ Channel marker panel
- ⑤ Operating keys
- ⑥ Door retainer
- ⑦ Steel housing to DIN 43 700 for flush panel mounting

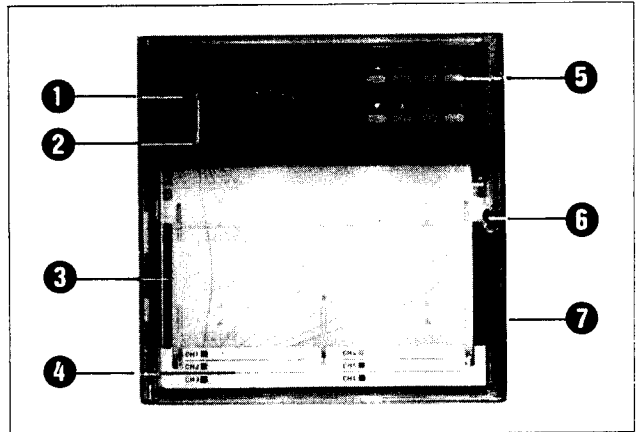

- ⑧ Back panel
- ⑨ Faston connectors for CH1 – CH6
- ⑩ Faston connectors for serial interface
- ⑪ Faston connectors for alarm contacts
- ⑫ Faston connectors for fault indication (e.g. chart end)
- ⑬ Faston connectors to DIN 46 244/A for mains supply

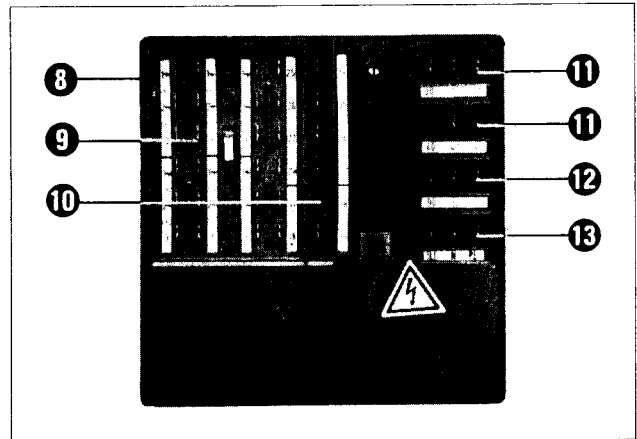

2 TECHNICAL DATA

2.1 Printing recorder for transducers with standard signal

Input

Current DC, voltage DC

Standard ranges

0 — 20 mA	Ri = 50 Ω
can be switched to	
4 — 20 mA	Ri = 50 Ω
0 — 1 V	Ri = 1 MΩ / V min.
0 — 10 V	Ri = 1 MΩ / V min.

isolated from each other by reed relays

2.2 General data

Inputs

digitised through U/f converter, isolation of input up to 50 V AC through conversion of the input signal into a frequency proportional to voltage which is then isolated by optocouplers and passed to the microcontroller.

Sampling rate: 6 channels in 4 sec.

Writing system

recording under microprocessor control through universal print head located above the chart cassette, 513 dots over 100 mm recording width

Dot size

0.2 — 0.25 mm

Operating inputs

freely selected chart speed, chart stop and text, operated externally through 6 floating contacts or PLC. Isolation through optocouplers

Limit comparator Ik7, Ik8

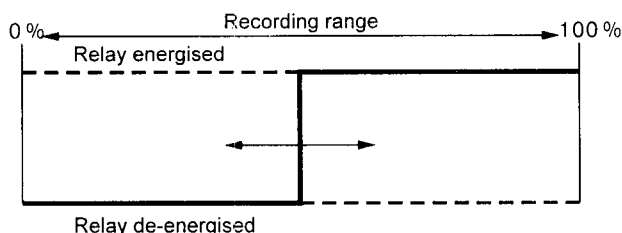

Ik7:

adjustable over the entire recording range.

Function:

relay is energised for value above limit

Adjustment range: 0.5 — 100 %

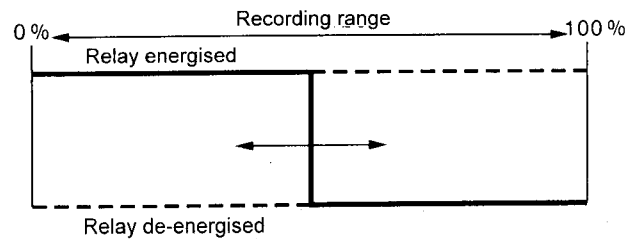

Ik8:

as Ik7 but relay action reversed

Limit relay

relay function Ik7, Ik8 selected by software, with and without acknowledgment, for signal above/below limit. For contact loading see connection diagram

Operating outputs (fault relay)

relay for message "chart end" and "printer not ready" (indicated on the front by flashing red LED)

Resolution

better than 0.2 %

Life of print head

more than 1 million dots per colour and tip

Printing colours

violet, red, black, green, blue, brown

Printing width

100 mm

Chart width

120 mm

Automatic cassette

for 16 m chart, visible chart length 70 mm, tear-off edge and automatic chart take-up

Chart

Roll chart, blank, unperforated, no name, 16 m long, paper thickness 47 μm

Chart drive

by stepping motor and gearbox

Chart speed

programmable from the keys: 0, 5, 10, 20, 60, 120, 240, 300, 600, 720 mm/h

2 TECHNICAL DATA

Chart speed change

(event changeover)

speed change:

1. on going above or below limit setting
2. to another speed during a programmable period of 1 h – 23:59 h max.
3. through external contact

Chart sensor

through light reflection sensor for chart end, indicated by flashing red LED, relay message and stopping of print-out (stepping motor and print head switched off)

Display

alphanumerical display of channel and measurement through 8-character LED matrix.

The numerical range of the display is ± 9999 .
The brightness can be adjusted in 7 steps.

Operating modes for printer and trace print-outs

Normal operation:

recording at the set chart speed

Limit operation:

recording only when above or below the set limits.

Mixed operation:

recording at set chart speed. Recording at different speed when going above or below limit settings.

The following apply to all three modes:

- daily statistical print-out available at programmed hour and minute
- statistical print-out available at programmed time intervals (1/2 h, 1 h, 1.5 h, 2 h, 3 h, 4 h, 6 h, 8 h, 12 h, OFF)
- MESSAGE REPORT at programmed time intervals (1/2 h, 1 h, 1.5 h, 2 h, 2.5 h, 3 h, 4 h, 6 h, 8 h, 12 h, OFF)
The time intervals are based on the full hour
- manually operated program print-out of programmed data
- supply failure

The following functions are initiated after the supply is restored:

- chart is tightened
(at fast forward speed 19 200 mm/h)
- print head moves to left stop
- print-out is synchronised to clock time; values are printed during this period but the diagram grid is omitted
- after synchronisation the grid is also printed.

Supply

secondary switch-mode power supply normally 230 V $\pm 10\%$, 48 — 62 Hz AC; 115 V AC selected by solder links

Power consumption

35 VA max.

Accuracy

Class 0.5 to DIN 57 410/VDE 0410

Electrical connection

through faston connectors to DIN 46 244/A
6.3 x 0.8 mm or twin 2.8 x 0.8 mm

Mains fuse on motherboard

G fuse insert M0.63 AE 250V DIN 41 571/2
(5 mm x 20 mm)

Electrical safety

according to instrument specification
VDE 0411, Part 1

Data back-up

on supply failure the set data are protected, clock time and date continue. Data protection more than 4 years at 15 — 25 °C ambient temperature

Deviations

recording accuracy:
better than $\pm 0.5\%$ full scale

resolution:
better than 0.25 %

sensitivity:
better than 0.2 %

ambient temperature error:
less than 0.2 % per 10 °C

2 TECHNICAL DATA

Construction

Housing

steel housing for flush panel mounting to
DIN 43 700, door with retainer, plastic back,
chassis can be withdrawn towards the front

bezel: 144 x 144 mm
depth behind panel: 260 mm
panel cut-out: $138^{+1.0} \times 138^{+1.0}$ mm

Permitted ambient temperature

0 to 50 °C

Permitted storage temperature

instrument:
-20 to +70 °C

print head:
(in undamaged original packing)
-20 to +60 °C

Climatic conditions

Class KWF to DIN 40 040,
rel. humidity 75 % max. annual mean,
no condensation

Operating position

NL90 ±15 to DIN 16 257 (vertical)

Protection

to DIN 40 050
front IP54, rear IP20

Weight

6 kg approx.

2 TECHNICAL DATA

2.3 Block diagram

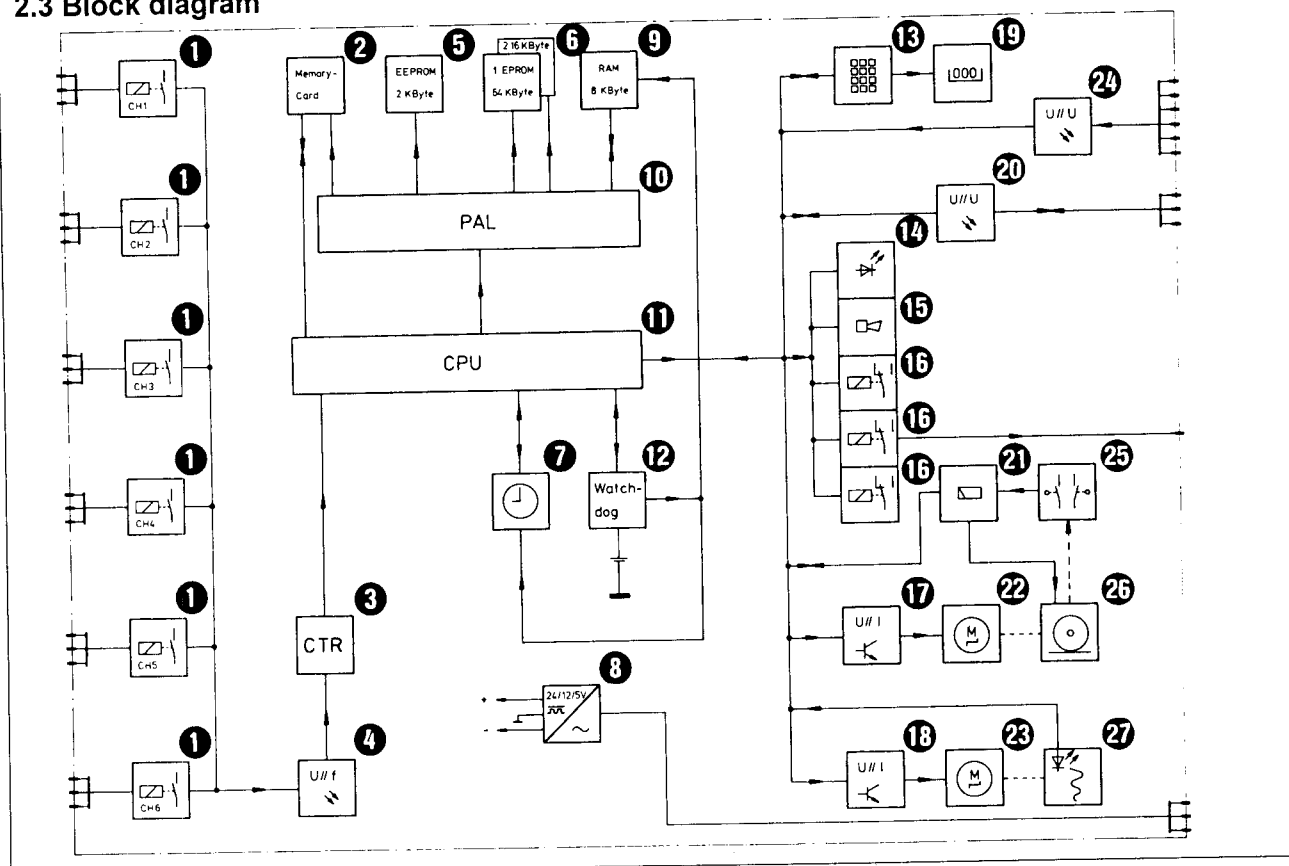

2.4 Operation

The microcontroller **11** provides central control of all functions in the LOGOPRINT C240. Its program is stored in 2 EPROMs **6**. The configuration data are stored in EEPROM **5**. A RAM **9** forms the data memory of the microcontroller. A plug-in memory card **2** can be used for data interchange with other instruments. All memories are selected by a programmable logic module **10**.

The watchdog **12** monitors the function of the microcontroller and initiates a re-start in case of a fault. The same module also switches the lithium battery to the clock **7** and the RAM **9** in case of supply failure or low voltage.

The six analogue inputs **1** are switched by reed relays (K1 - K6) to the voltage/frequency converter **4**. The converter generates a frequency of 100 Hz to 10.1 kHz which is isolated by an optocoupler from the digital section. The counter **3** is used to measure the frequency which is evaluated by the microcontroller.

The recorder is operated with eight keys **13** and an 8-character alphanumerical LED display **19**.

Alarms and faults are signalled by 3 relays (K7 - K9) **16**, an LED **14** on the front, and a piezo beeper **15**. Either an RS232 or an RS422/485 interface is available, separated by optocoupler **20** from the digital section. The six inputs **24** with optical isolation are used for various operating functions.

The print head control **21** operates the six colours of the print head **26**. The print head is driven by a stepping motor **22**. The motor driver **17** operates the bipolar stepping motor at constant current. The zero and full-scale sensors **25** prevent the print head hitting the sides of the chassis. The stepping motor **23** provides the chart drive; it is operated by a constant-current driver **18**. The end of the chart operates an infra-red sensor **27** which stops the chart drive through the microcontroller. An LED **14** and the fault relay **16** indicate this condition.

All supply voltages are generated by a secondary switch-mode power supply **8**.

2 TECHNICAL DATA

2.5 Dimensions

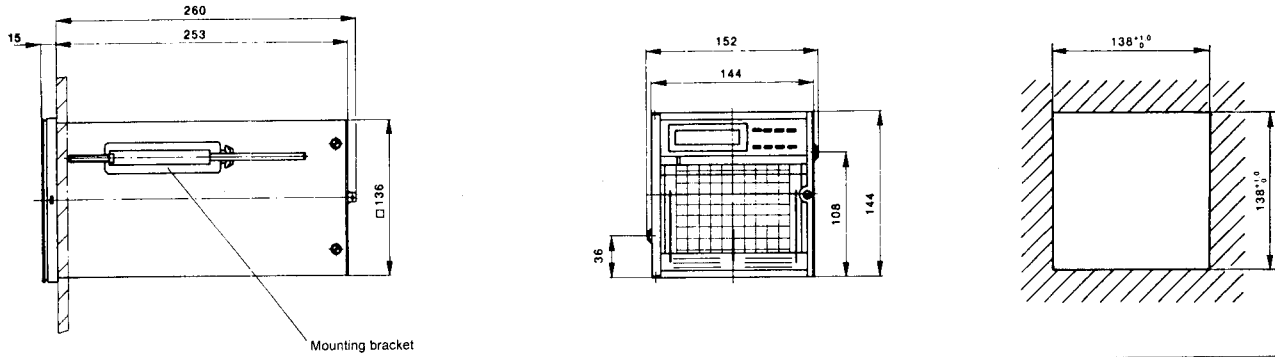

Code tm

Housing with carrying handle, rubber feet and terminal cover, also 3 m mains cable with grounded plug

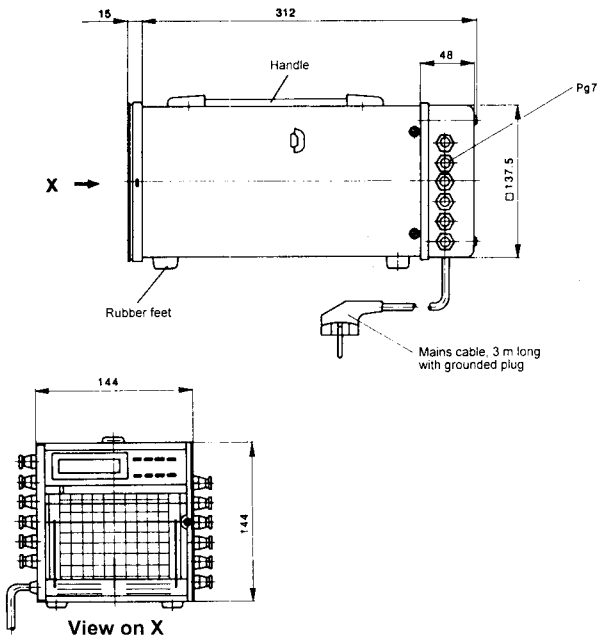

Code ab

Housing for wall mounting. The panel-mounting housing is fitted in a carrier and can be swung out through 90°.

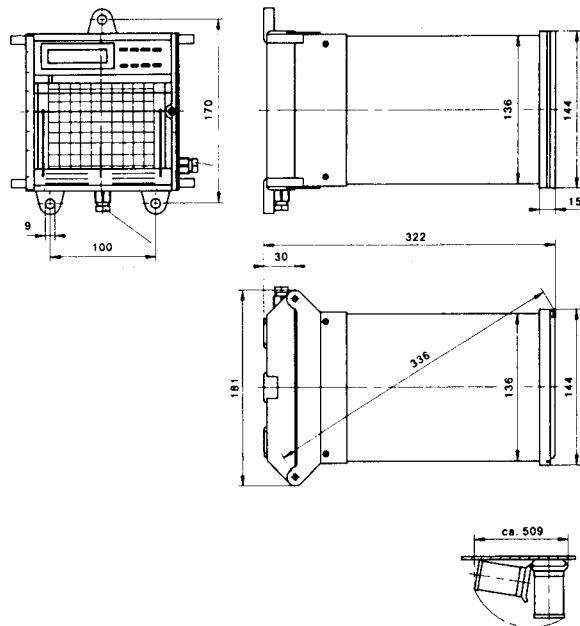

Code TRS-36

Portable recording station for varying applications in mobile use and for monitoring process variables

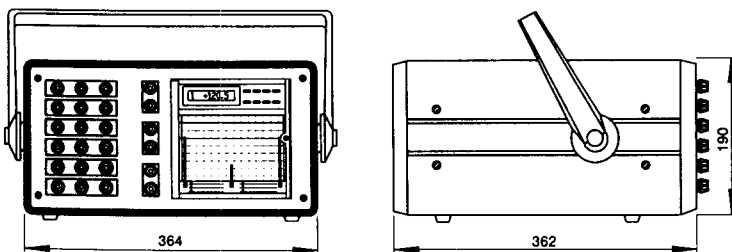

mm	inch	mm	inch
0.2	0.008	144	5.67
0.25	0.01	152	5.98
0.8	0.031	170	6.69
2.8	0.11	181	7.13
6.3	0.25	190	7.48
9	0.35	253	9.96
15	0.59	260	10.24
30	1.18	312	12.28
36	1.42	322	12.68
48	1.89	336	13.23
70	2.76	362	14.25
100	3.94	364	14.33
108	4.25	509	20.0
120	4.72		
136	5.35	3 m	10 ft
137.5	5.41	16 m	53 ft
138 ₀ ^{+1.0}	5.43 ₀ ^{+0.04}		

3 INSTALLATION

3.1 Location and climatic conditions

The instrument location should as far as possible be free from shock and vibrations. Stray electromagnetic fields, e.g. from motors, transformers etc., should be avoided. The ambient temperature at the instrument location should be between 0 and 50 °C at a relative humidity of not more than 75 %. Corrosive air or fumes reduce the life of the instrument.

3.2 Important notes

- Provide an isolating switch and fuse for each instrument.
- When the supply is subject to interference (e.g. thyristor drives) the instrument should be supplied through an isolating transformer.
- All sensor and signal lines should, where possible, be run separately from the control and supply cables (in separate, independent cable ducts).
- Use wiring layout in star configuration including protective ground.

- Screened measuring and signal cables should only be grounded at the electronic instrument.
- Where possible provide physical separation between electronic units and contactors.
- Provide RC modules on the contactor or solenoid valve as this is often the source of interference. All manufacturers of these units are aware of this problem and offer suitable RC modules in their catalogues.

3.3 Fitting in position

The recorder is inserted from the front into the panel cut-out. The two mounting brackets ① are inserted from behind the panel into the cut-outs at the sides of the housing; the flat sides of the brackets must be against the housing. The brackets are then placed against the rear of the panel and tightened up evenly.

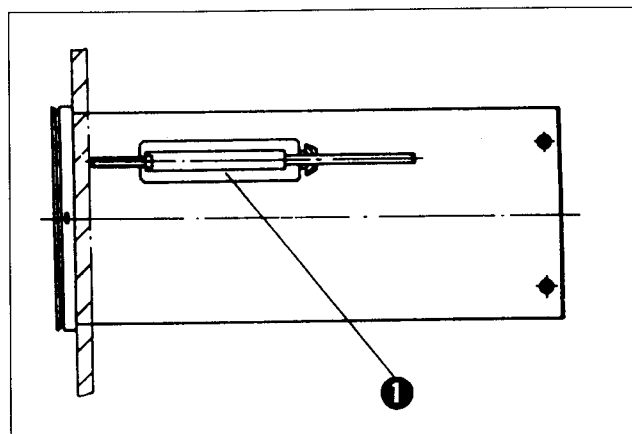

3 INSTALLATION

3.4 Electrical connection

The choice of cable and the connection of the supply line must conform to the requirements of VDE 0100 "Regulations on the Installation of Power Circuits with nominal voltages below 1000 V" or the appropriate local regulations.

The electrical connections to the printing recorder are made with faston connectors 6.3 x 0.8 mm or twin 2.8 x 0.8 mm to DIN 46 244/A.

3.4.1 Connection diagram

Rear view with faston connectors

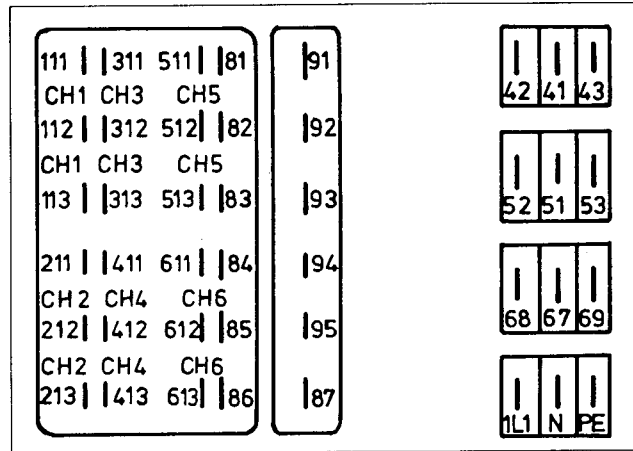

NOTE!

Relay contacts (*) must not be connected with both low-voltage safety circuits (SELV) and mains circuits!

Connection for	Code	Terminals	Diagram		
Supply as on label		1L1 line N neutral PE protective ground power consumption: P = 35 VA max.			
Input	e	Input . = Channel 1 – 6 (CH1 – 6) Inputs isolated from each other			
Current or voltage		.11 + .12 -			
Limit contacts	Relay 1	42 (P) common relay* 41 (O) n.c. (break) 250 V AC 3 A 43 (S) n.o. (make) 30 V DC 3 A			
	Relay 2	52 (P) common relay* 51 (O) n.c. (break) 250 V AC 3 A 53 (S) n.o. (make) 30 V DC 3 A			
Fault message (e.g. chart end etc.)		68 (P) common relay* 67 (O) n.c. (break) 250 V AC 3 A 69 (S) n.o. (make) 30 V DC 3 A			
Logic operating inputs		81 Operating input 1 82 Operating input 2 83 Operating input 3 84 Operating input 4 85 External chart speed 86 Recording stop 87 Operating inputs ⊥			
Serial interface		RS232	RS422	RS485	
		91	RxD	A(+) sending	A(+) sending/
		92	TxD	B(-) pair	B(-) receiving
		93	RTS	A(+) receiving	pair
		94	CTS	B(-) pair	
		95	GND	GND	GND

4 OPERATION

4.1 Operating modes

Normal operation:
recording at standard chart speed

Limit operation:
recording only when above or below the set limits.

Mixed operation:
recording at set standard speed. Recording at different speed when going above or below limit settings.

EXAMPLE: The instrument records the input signals at a slow speed. If one of the signals goes above or below its limit, the recorder switches to the fast limit speed, acknowledges the change-over, and now records all the signals with increased time resolution.

When the signal is again in the non-limit range the recorder returns to the standard speed (with acknowledgment).

4.1.1 General notes on recording

Switching on the supply

The following functions are always performed after the supply is switched on:

- chart is tightened by 3 mm at the fast forward speed
- print head moves to the left stop and then prints a line across the whole writing width
- print-out is synchronised to clock time; values are printed during this period but the diagram grid and the grid texts are omitted
- after synchronisation the grid and grid texts are also printed
- the synchronisation status can be recognised by the form of the "grid crosses":

standard:

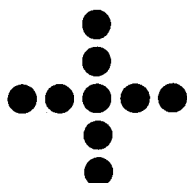

printing synchronised from this point:

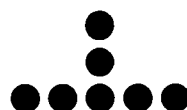

Printing direction

Measured values and grid are printed while the print head moves from 0 % to 100 %.

Texts are printed while the print head moves from 100 % to 0 %.

Letters and special symbols are printed in a 7 x 9 matrix.

Grid

A grid cross consists of 5x5 dots. The resolution of the print head in the time direction (x axis) is 600 dots, in the amplitude direction (y axis) 513 dots over 100 mm writing width.

Fixed colours are assigned to the grid crosses and grid lines:

0 % = 1 step	grid line	violet
20 % = 102 steps	grid cross	red
40 % = 205 steps	grid cross	black
60 % = 307 steps	grid cross	green
80 % = 410 steps	grid cross	blue
100 % = 513 steps	grid line	brown

The following relationship applies to chart speed and time in the time direction:

5 mm/h:	one grid cross line every	4 h
10 mm/h:	one grid cross line every	2 h
20 mm/h:	one grid cross line every	1 h
60 mm/h:	one grid cross line every	20 min
120 mm/h:	one grid cross line every	10 min
240 mm/h:	one grid cross line every	5 min
300 mm/h:	one grid cross line every	4 min
600 mm/h:	one grid cross line every	2 min
720 mm/h:	one grid cross line every	2 min

4 OPERATION

Figuring of time, date and instrument designation

The time is printed every 20 mm (24 mm at 720 mm/h chart speed) at the beginning of the grid cross. The position is on the left at the 0 % line.

The time print-out is synchronised to the date change. The date print-out is combined with the print-out of the chart speed and the instrument designation.

The result is the following relationship:

Speed	Time print-out	Spacing	Date, speed, instrument designation
5 mm/h	4 h	20 mm	after date change 00:00 h
10 mm/h	2 h	20 mm	after date change 00:00 h
20 mm/h	1 h	20 mm	00:00 h, 12:00 h
60 mm/h	20 min	20 mm	00:00 h, 04:00 h, 08:00 h, ...
120 mm/h	10 min	20 mm	00:00 h, 02:00 h, 04:00 h, ...
240 mm/h	5 min	20 mm	00:00 h, 01:00 h, 02:00 h, ...
300 mm/h	4 min	20 mm	every 48 minutes, starting at 00:00 h
600 mm/h	2 min	20 mm	every 24 minutes, starting at 00:00 h
720 mm/h	2 min	24 mm	every 24 minutes, starting at 00:00 h

Priorities

Events can not be indicated simultaneously; the sequence is therefore determined by the order of priority. This means that if several events occur, the event with the highest priority takes precedence.

Event	Priority*
Start of summer time S TIME B	15
End of summer time S TIME E	14
Stop key	13
External stop	12
Chart end stop	11
Code number stop	10
Print test	9
Service print	8
Program parameter	7
Message report	6
Daily report	5
Measuring period report	4
Feed limit	3
Feed external	2
Feed time	1
Feed paper	0

*15 = highest priority
0 = lowest priority

Alternating printing colour for time, date, chart speed, instrument designation

Chart speed change

The chart speed can be changed by the following events:

1. Chart speed (FEED PAPER) is re-programmed
2. Period for FEED TIME has been reached
3. Chart speed above or below limit setting (FEED LIMIT) must be set
4. External contact (FEED EXTERN) closed
5. Printing has been stopped
6. Report is printed out

For chart speeds other than 0 mm/h the change-over is indicated by a line over the full writing width.

The event which caused the chart speed change is indicated by the type of line:

- ① FEED PAPER
- ② FEED LIMIT
- ③ FEED EXTERNAL
- ④ FEED TIME

The line colour alternates

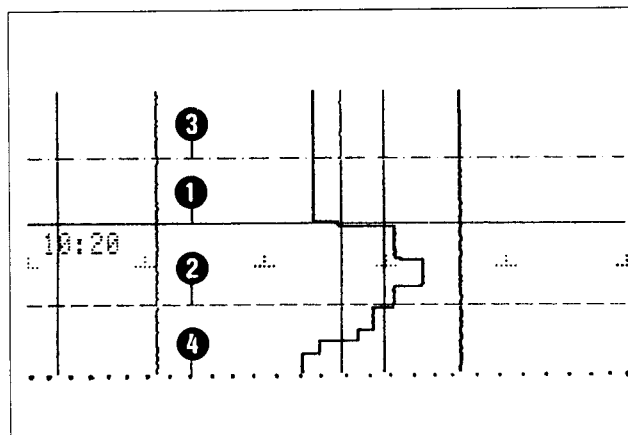

4 OPERATION

Printing colours

Channel data

Channel designation (WORD+NO), unit, scale and limit marks are printed in the channel colour.

Chart speed (FEED), date (DATE) and recorder designation (UNITWORD) are printed cyclically in a different colour (equal wear on all colour tips).

The time print-out takes place in alternating colours. The sequence corresponds to the colour sequence.

Print-out

- ❶ Chart speed (here FEED LIMIT)
- ❷ Time, date and recorder designation
- ❸ Grid crosses
- ❹ Low limit
- ❺ High limit
- ❻ Channel number
- ❼ Scaling
- ❽ Channel designation with unit (measurement unit)

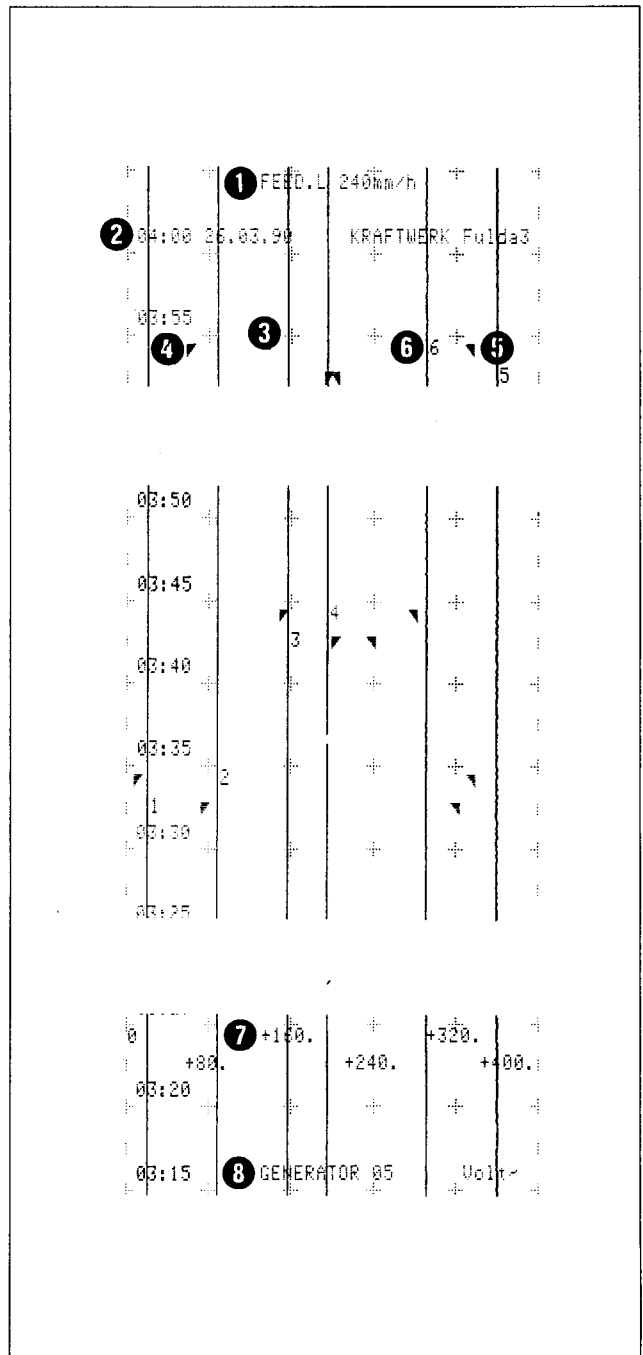

4 OPERATION

PLOTAREA (plotting range)

Example:

A working range of 200 — 800 °C has to be selected from the full input range 0 — 1000 °C for recording over the full chart width. To do this the plotting range (PLOTAREA - see configuration level 1) of the corresponding channel must be set to 20 – 80 %.

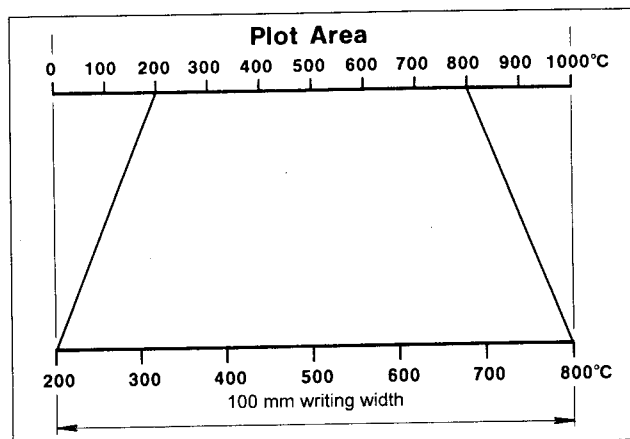

OFFSET

When measurement traces run into each other and become unclear, they can be separated by generating strips (OFFSET).

Scaling only with start and end value.

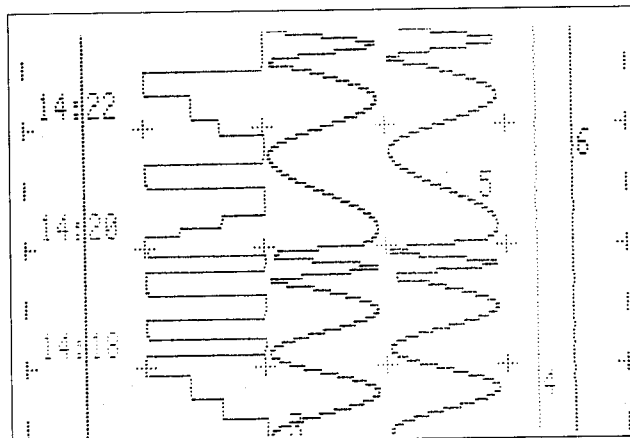

Limit settings

The measurement traces are marked cyclically with their channel number and the corresponding limit settings in the appropriate colour.

The spike ❶ indicates the limit setting.

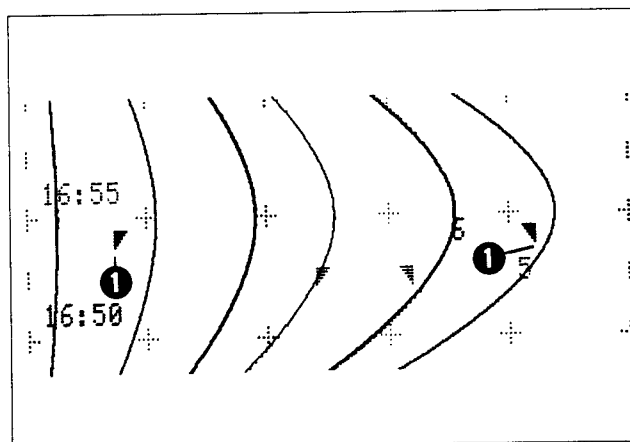

4.1.2 Print-out modes

PROGRAM PARAMETERS (program print-out)

Pressing key  in the base status produces a tabulated print-out of the parameter settings for all channels.

PROGRAM PARAMETERS				
14:31 09.04.90	KRAFTWERK Fulda3			
CH	WORD+NO	ZERO	REL-1	DIM
	INPUT	FULL	REL-2	STATUS
1	Kohlenstau 0..20mA	000.0 +800.0	+145.8 +650.0	°C ON
2	DAMPFTURBI 0..20mA	0000. +6000.	+0100. +5100.	1/min ON
3	GENERATOR 0..10V	000.0 +400.0	+198.5 +242.5	Volt ON
4	GENERATOR 0..10V	+010.0 +140.0	+050.5 +102.3	Amp. ON
5	Abwasser K 4..20mA	+03.00 +11.00	+06.85 +08.15	pH ON
6	PUMPE Kuhl 0..1V	000.0 +650.0	+095.0 +550.0	m³/h ON
FEED.PLOT 60, LIM 240, EXT 120mm/h				
FEED.TIME 10mm/h 16:15h - 07:00h				

4 OPERATION

DAILY REPORT*

(daily statistical print-out)

The calculated mean, the minimum and maximum values of the day together with the time when they occurred, and the instantaneous value are printed out daily at a programmable hour and minute.

This applies to all activated channels. The print-out can be omitted. The print-out interrupts the recording mode.

DAILY REPORT			KRAFTWERK Fulda3		
CH	DATE	TIME	MIN MAX	AVERAGE MOMENT	WORD+NO DIM
1	07.04	16:40	+010.9	+025.5	Kohlens
	07.04	15:56	+040.0	+032.0	°C
2	07.04	15:41	+0356.	+0825.	DAMPFTU
	06.04	23:49	+1292.	+1038.	l/min
3	07.04	16:40	+042.0	+097.2	GENERAT
	07.04	15:56	+152.1	+122.1	Volt
4	07.04	16:40	+028.3	+052.4	GENERAT
	07.04	07:38	+076.4	+063.2	Amp.
5	07.04	07:52	+04.93	+07.48	Abwasse
	06.04	23:48	+10.01	+08.64	pH
6	07.04	07:52	+127.4	+295.3	PUMPE K
	07.04	03:43	+462.1	+371.9	m³/h
REPORT-BEGIN : 06.04.90 17:00					
REPORT-END : 07.04.90 17:00					

MEASURING PERIOD REPORT*

(periodic statistical print-out)

This is a periodic print-out (with reset) of the instantaneous value, the calculated mean, and the minimum and maximum for the preceding period together with the times when they occurred.

This applies to all activated channels (not omitted, i.e. ON or OFFP).

- ① = measurement values underrange
- ② = measurement values overrange
- ③ = mean can not be calculated through underrange or overrange

PERIOD REPORT			KRAFTWERK Fulda3		
CH	DATE	TIME	MIN MAX	AVERAGE MOMENT	WORD+NO DIM
1	10.04	07:53	+008.0	+023.4	Kohlens
	10.04	07:49	+036.2	+028.8	°C
2	10.04	07:53	+0247.	+0760.	DAMPFTU
	10.04	07:49	+1171.	+0934.	l/min
3	10.04	07:54	+110.5	>>>>>	GENERAT
	10.04	07:52	>>>>>	>>>>>	Volt
4	10.04	07:53	+022.8	+050.3	GENERAT
	10.04	07:45	+093.0	+058.7	Amp.
5	10.04	07:50	<<<<<	+10.98	Abwasse
	10.04	07:58	+10.98		pH
6	10.04	07:53	+094.0	+272.1	PUMPE K
	10.04	07:49	+420.9	+332.5	m³/h
REPORT-BEGIN : 10.04.90 07:30					
REPORT-END : 10.04.90 08:00					

MESSAGE REPORT*

Setting of the interval for printing out the collected alarm texts and other external contacts (up to 24 alarm texts CH1 – CH6 and 8 texts of the external contacts E1 – E4). The print-out always takes place based on the full hour.

13:00 09.04.90 MESSAGE REPORT					
CH	TIME	DATE	STATUS	RELAY	
04	12:30	09.04	OFF	UNTERLAST	1
04	12:31	09.04	OFF	SPANNUNG tief	1
04	12:31	09.04	ON	Netztrennung	
04	12:32	09.04	OFF	alkalisch	1
04	12:34	09.04	ON	sauer	
04	12:35	09.04	ON	DREHZAHLGRENZE	00
04	12:35	09.04	ON	UBERLAST	00
06	12:35	09.04	ON	VOLLE FÖRDERLEI	2
06	12:37	09.04	ON	Netzeinspeisung	
06	12:37	09.04	ON	SPANNUNG hoch	2
06	12:42	09.04	OFF	SPANNUNG hoch	2
06	12:44	09.04	OFF	VOLLE FÖRDERLEI	2
04	12:44	09.04	ON	Netztrennung	
04	12:45	09.04	OFF	UBERLAST	00
04	12:45	09.04	OFF	DREHZAHLGRENZE	00
04	12:45	09.04	OFF	sauer	00
04	12:48	09.04	ON	alkalisch	1
04	12:49	09.04	ON	SPANNUNG tief	1
04	12:49	09.04	ON	UNTERLAST	1

NOTE:

The message "NO MESSAGE" does not imply that there are no alarm conditions at that instant. It only indicates that no change from the last MESSAGE REPORT has been recognised.

15:35					
15:30 09.04.90 NO MESSAGE					
15:25			+320.		+640.

* Setting at configuration level 2

4 OPERATION

SERVICE PRINT* (Service print-out)

Print-out of date, time, software version, number of "POWER DOWNS" and operating time in hours.

```
10:30
-----
10:26 09.04.90 SERVICE-PRINT
PROGRAM NAME : 034.01.01
NO. OF POWER DOWNS : 00036
OPERATION TIME [h] : 00237
-----
```

PRINTTEST* (test of print-out)

Test of print head and quality of colour tips.

```

-----
ABCDEFGHIJKLMNOPQRSTUVWXYZ
abcdefghijklmnopqrstuvwxyz
0123456789
<<XffPαβδΔλθμσΣτφωΑαΗβΘϒϒ→r²fY
!"#$%&'()*+,-./:;<=>?@[\]^_
( ) ~ * ^ > ; ° ÷ ± √ ∞ ∅
-----
```

NOTE:

Stopping the recording interrupts the current report print-out. The reports due during a recording stop are printed out after the start.

* Setting at the operating level

4 OPERATION

4.2 Preparation

4.2.1 Checking the supply voltage

The supply voltage must agree with the one marked on the instrument label. The label is affixed to the top of the housing.

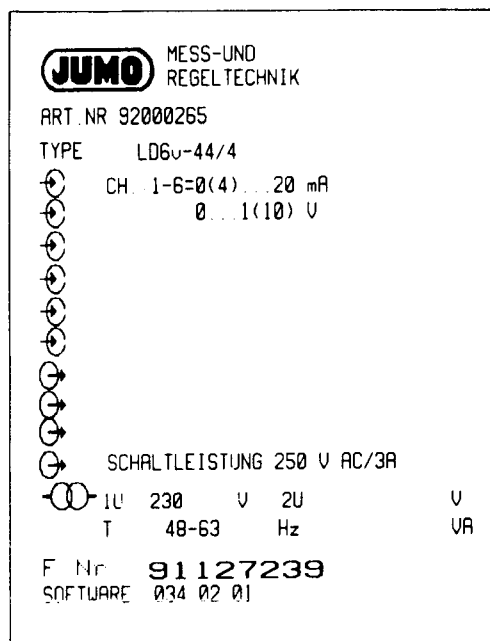

4.2.2 Opening the housing door

The accessories include two keys for the housing door. Turning the key a quarter turn anticlockwise releases the door. With the finger tips pull the right side of the door forward to open it.

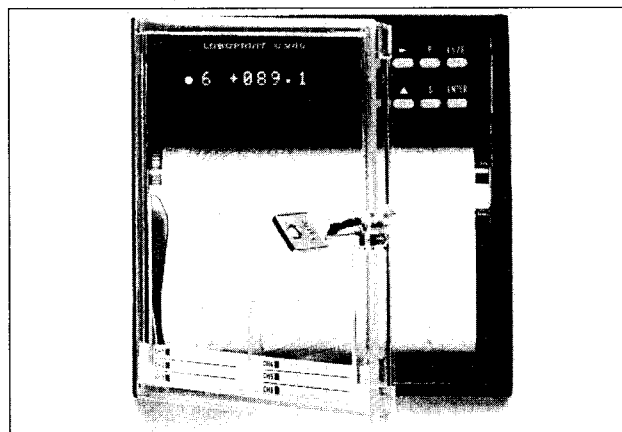

4.2.3 Marking the channel label

The channel label is marked with the channel designations (text as programmed) and the corresponding measuring range.

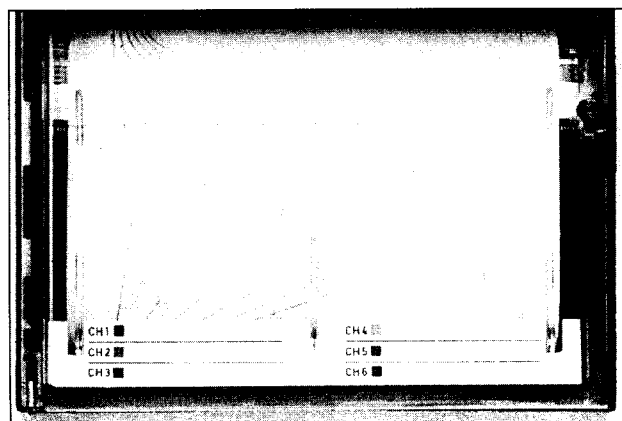

4 OPERATION

4.2.4 Fitting the print head

WARNING!

When the recorder is started up for the first time it is essential that the sequence below is observed, otherwise the function of the automatic pen lift can not be ensured.

1. Connect up the instrument
2. Switch on the supply
3. Insert the print head ①

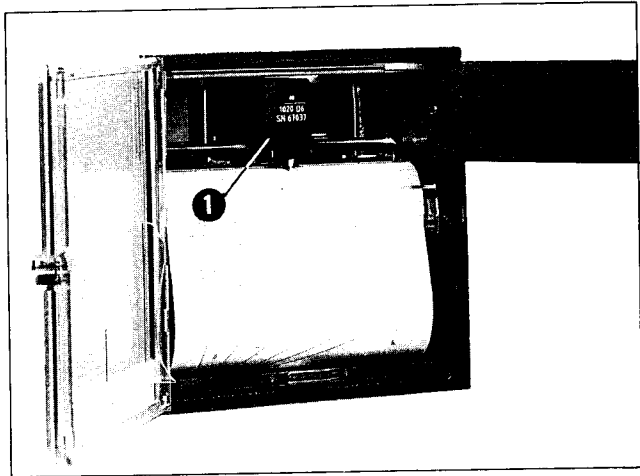

4.2.5 Connection of the external operating inputs (example)

NOTE:

The contact must be closed for at least 4 sec to ensure that the operating inputs produce a function.

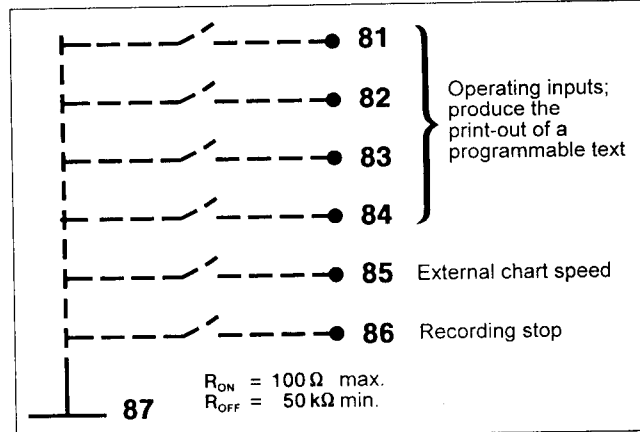

4.2.6 Removing the chart cassette and chassis

Open the housing door. Push the locking lever ① to the right and pull forward. Swing the auto-cassette upwards and pull it out.

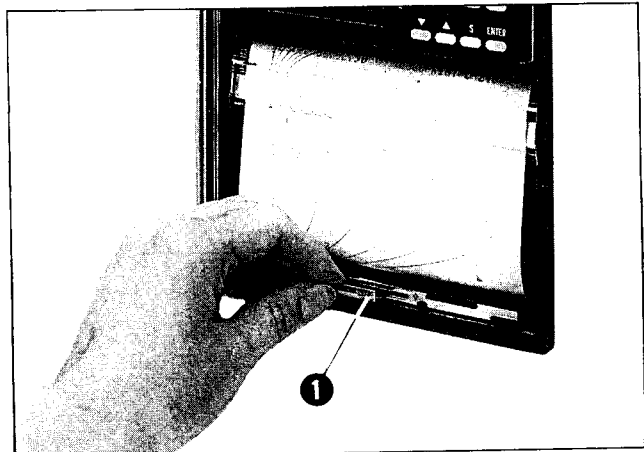

Push the safety lever ② towards the back with a screwdriver. Push the locking lever ③ towards the right and pull out the chassis, pulling **only** by the metal part ④.

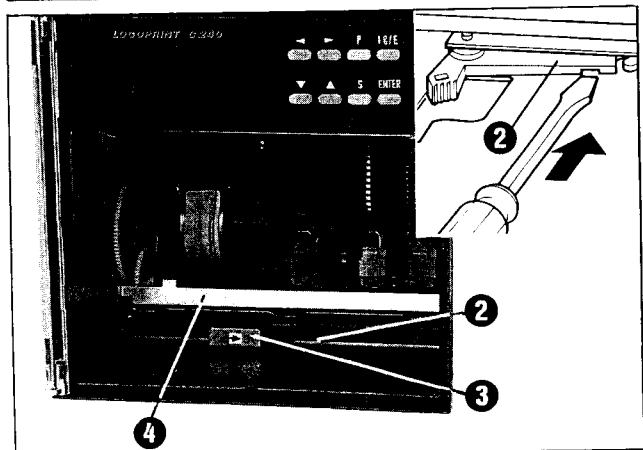

4 OPERATION

After work has been completed slide the chassis back into the housing until the locking lever **1** clicks home. Then swing back the safety lever **2** with a screwdriver until it clicks home. Insert the chart cassette and close the housing door.

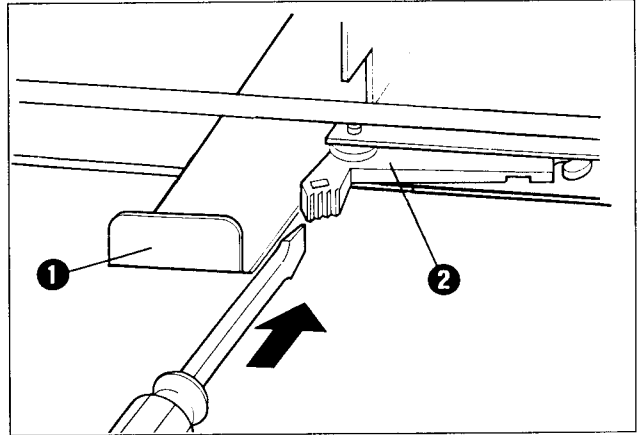

4.2.7 Changing the inputs

Remove the chassis from the housing. Switch positions 1 – 6 are assigned to the inputs CH1 – CH6.

“open” = voltage input
unmarked = current input

Switches 7 and 8 always in the “open” position!

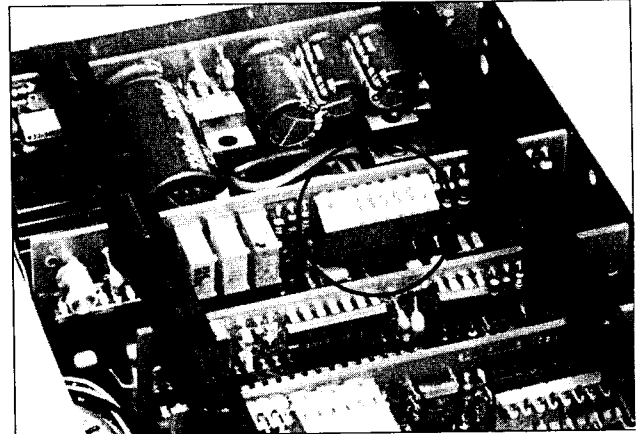

NOTE:

When using gk resistors the switches must be set to voltage input, i.e. set to "open".

4.2.8 Supply for the operating inputs

Remove the chassis from the housing. Partly pull out the interface board **3**. The supply for the operating inputs can be changed by 6 switches from internal supply to external supply.

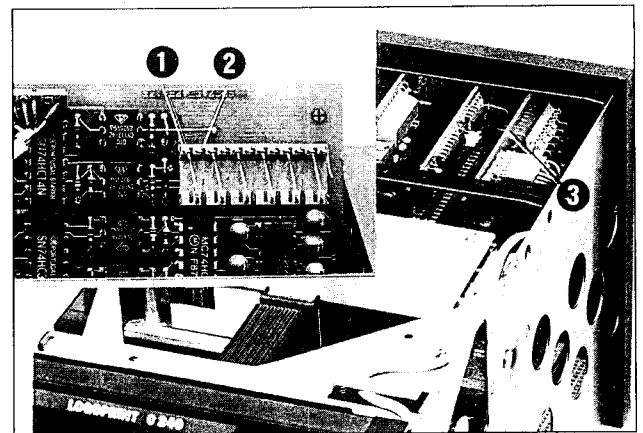

Switch in position **1**:

operating input with external supply (e.g. PLC)
not activated 0 — 5 V DC
activated 20 — 35 V DC

Example (recording stop) see Fig. A alongside

Switch in position **2**:

operating input with internal supply
(only a contact is required externally).
not activated $R_{OFF} = 50 \text{ k}\Omega \text{ min.}$
activated $R_{ON} = 100 \text{ }\Omega \text{ max.}$

Example (recording stop) see Fig. B alongside

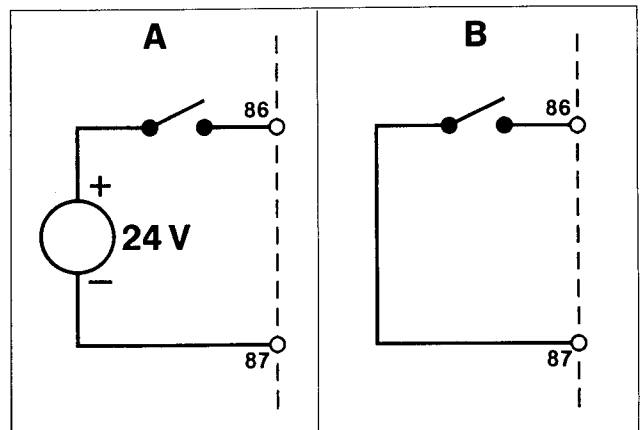

The 6 switches can be set independently of each other.

4 OPERATION

4.3 Operation / Programming

NOTE:

Please fold out the page marked OPERATING NOTES / PROGRAMMING at the beginning of these Operating Instructions when reading the following pages.

It contains the description of the key and LED functions, 2 sequence diagrams for access to the various levels and input of the parameters. Incorrect input produces the display ERROR!

Remedy:

Press key  and enter the parameter again.

Base status

After 30 sec max.

WAITING

Cyclic display of
 - channel designation
 - measured values
 - unit
 - alarm message

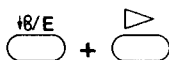

- acknowledgment of alarm



- initiate program print-out

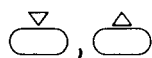



- fast forward / backward



- interrupt and start recording



- switching display from cyclic to static;
 selection with  or 
No alarm messages are shown in the static display

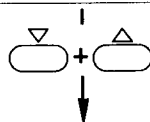
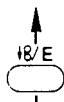

(see next page)

4 OPERATION

(see previous page)

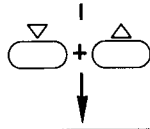
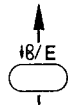

Operating level (Level S)

Display	Setting of
FEED P.	Chart speed in mm/h
PLOTSTAT	Plot status (for channels 1 – 6) ON: measured values are printed OFFP: no printing of measured values, but taken into account in "DAILY REPORT" and "MEASURING PERIOD REPORT"
DISPLAY	Brightness of display
SE.PRINT	Service print-out
PRTEST	Print test

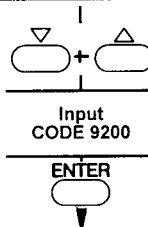
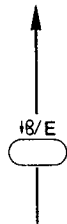

if an incorrect Code number is entered, the parameters can be viewed but cannot be changed.

IMPORTANT!
All collected report data are erased by input 9200!

Parameter level (Level P)

Display	Setting of
DATE	Date
TIME	Clock time
S TIME B	Start of summer time (day, month, year - time)
S TIME E	End of summer time (day, month, year - time)
PIEZO	Piezo beeper - setting whether piezo beeper is switched on in case of alarm or not
FILTER	Time constant for filtering the measurement data

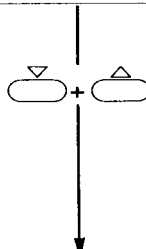

(see next page)

4 OPERATION

(see previous page)

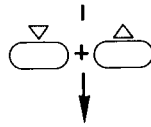
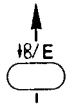

Configuration level 1 (Level C1)

Display	Setting of the channel parameters
STATE	Selection of channel status "ON" or "OFF" (display or printing).
WORD+NO	Channel designation (15 characters, total character set)
TYP 4	Selection of ranges
DEC/DIM	Selection of decimal point format, input of channel unit (6 characters, entire character set)
SCALE	Selection of scale for start (Z) and end (F); range -9999 to +9999 (decimal point selection by key P)
RELAY	1 limit setting each for alarm relays 1 and 2 (for each channel)
REL-1	Alarm relay 1 (On or Off)
REL-2	Alarm relay 2 (On or Off)
LIMTXT-1	Alarm text when alarm relay 1 is activated – print-out in MESSAGE REPORT (15 characters; entire character set)
LIMTXT-2	Alarm text when alarm relay 2 is activated – print-out in MESSAGE REPORT (15 characters; entire character set)
LIMIT.F	Input of low (L) and high (H) limits; underlimit/overlimit changes over to limit speed (FEED.L)
PLOTAREA	Selection of low (L) and high (H) presentation range in plot (see page 13)
OFFSET	Limitation of writing width with start value (L) and end value (H) in mm (see page 13)
COPY	Copying the data from channel (Source X) to channel (Dest. Y) (see example page 23)

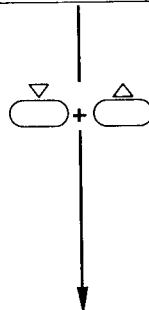

(see next page)

4 OPERATION

(see previous page)

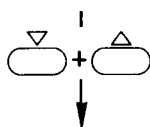
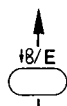

Configuration level 2 (Level C2)

Display	Setting of general parameters
UNITWORD	Designation of printing recorder (15 characters, entire character set)
BEGINTXT	Input of a text printed on each fresh start of recording – unless it consists entirely of blank characters.
ENDTXT	Input of a text printed at the end of recording – unless it consists entirely of blank characters.
REL.F.1	Function of alarm relay 1 (Ik7,Ik8)
REL.F.2	Function of alarm relay 2 (Ik8,Ik7) } interdependent
FEED.L	Selection of chart speed in case of an alarm event
FEED.E	Selection of chart speed in case of an external signal
FEED.T	Selection of chart speed in case of a time window from XX:XX hours (B) to YY:YY hours (E)
QUIT	Acknowledge alarm relay message YES/NO. Acknowledgment with (+).
D REPORT	Daily statistical print-out - setting whether active (ON) or inactive (OFF) and time
M.P.R.	Periodic summary print-out – setting the time interval between the start of two print-outs, or inactive (OFF)*
M REPORT	Message Report – setting the time interval between the start of two print-outs**, or inactive (OFF)
EXT.CONT	4 external contacts produce the print-out of a freely definable text*** (15 characters, entire character set)
COUNTER	Counters for external contacts (4), can be switched off with “OFF”. Count start can be set (counting pulse must be longer than 4 sec.)
EC DIR	Decision whether the text of EXT.CONT appears only in the MESSAGE REPORT (input: MREP) or together with the count (COUNTER) during recording (input: MREP+PAP)
MEM CARD	Copying the programming data from the memory card to RAM (CPY MC → R) or vice versa (CPY R → MC). Acknowledgment with YES or NO
FUNCTEST	For service use only
PRESET	Loading a standard program
SERIAL	Selecting the interface (RS 232C, RS422/485)
BAUD	Setting the baud rate
D-FORMAT	Setting the data format
MODE	Selection between print mode and communication mode

* Print-out always takes place referred to the time of the DAILY REPORT.









** Print-out always takes place referred to the full hour.

*** The texts are printed in the MESSAGE REPORT.



















4 OPERATION

Programming examples

Example 1: Setting the chart speed

Function keys	Procedure
 + 	Move from base status to operating level
 / 	Selection of "FEED.P" parameter
	Display of set chart speed
 / 	Selection of new chart speed
	Entering the new chart speed
	Move from operating level to base status

Example 2: Copying all parameters from channel 1 to channel 2

Function keys	Procedure
2x  + 	Move from base status to parameter level
Input "9200"	
	
 + 	Move from parameter level to configuration level 1
 / 	Selection of "COPY" parameter
	Display of data source
 / 	Selection of data source required
	Display of destination (Dest. 1)
 / 	Selection of destination required (Dest. 2)
	Display whether data transfer is enabled
 / 	Copying procedure enabled
	
3x 	Move from configuration level to base status

4 OPERATION

4.4 Removing the chart

Open the housing door, press key . LED acknowledges recording stop. Push down on the ledge **1**. Cassette unit swings up.

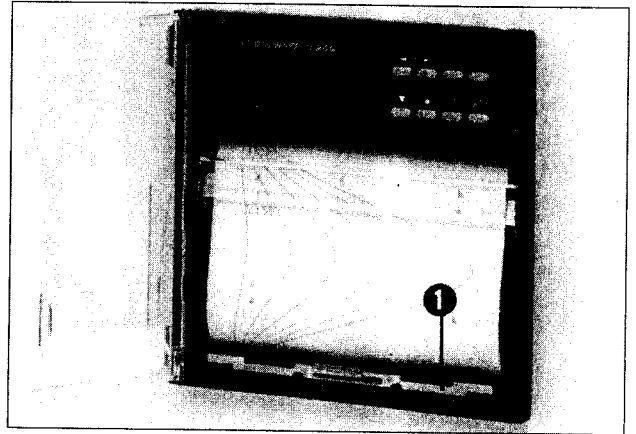

NOTE:

Transport the chart with the key  up to the required tear-off position.

Pull out chart downwards and tear off upwards against the rule **2**.

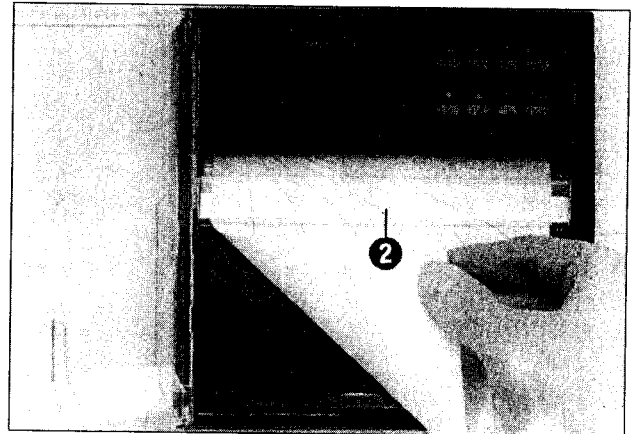

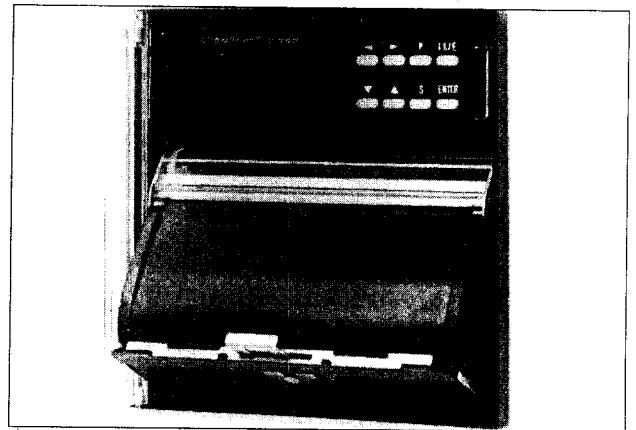

Push the cassette unit down again until it clicks home. Press key . The LED goes out. Close the housing door.

The chart is taken up automatically at the set chart speed while the door is closed.



4.5 Inserting the memory card

Open the housing door, press key . LED acknowledges recording stop. Remove the chart cassette. The memory card, with the writing to the left and the arrow towards the front, is pushed into its slot until it clicks home. Replace the chart cassette. Press key . Close the housing door.

WARNING!

When the recorder is switched off the memory card must be removed from the instrument. **Otherwise the back-up battery is being discharged!**

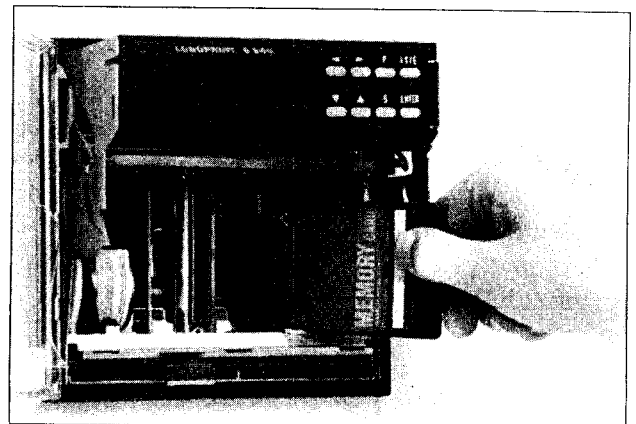

5 CHANGING CONSUMABLES

5.1 Changing the chart roll

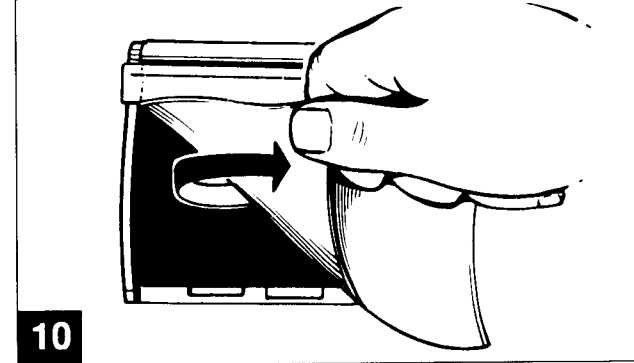
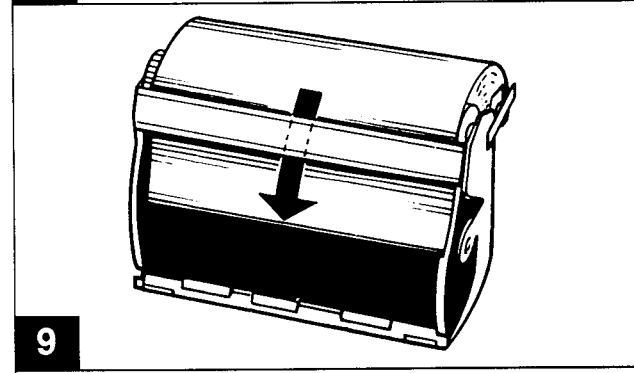
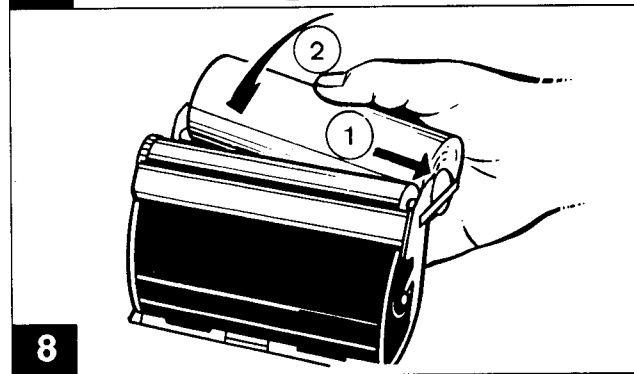
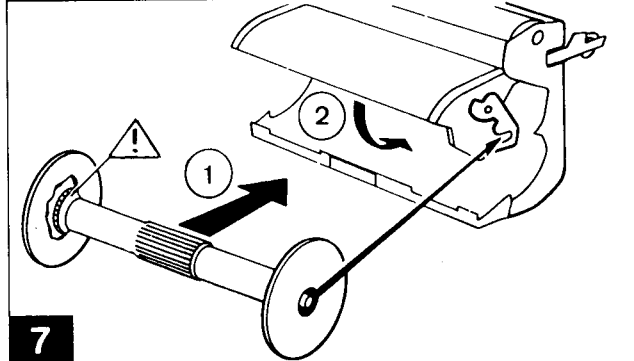
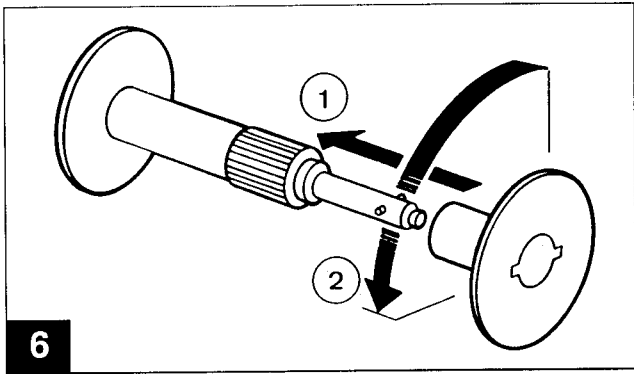
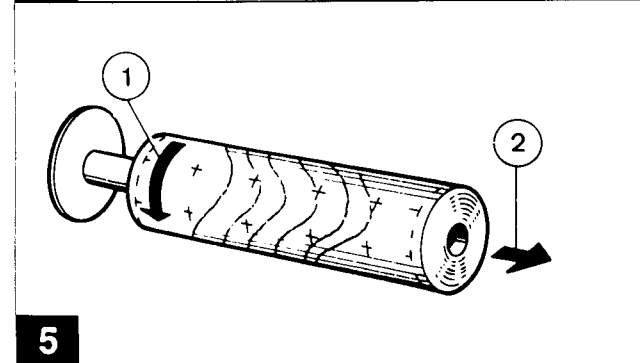
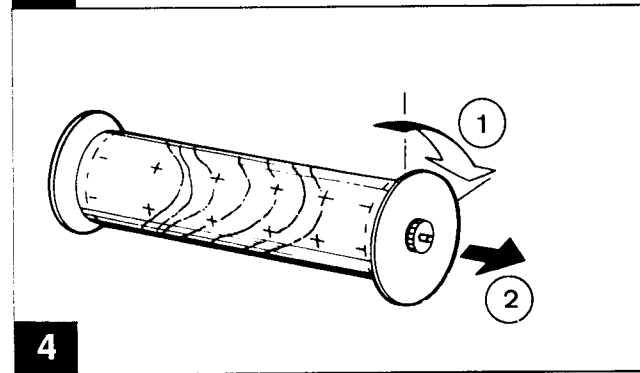
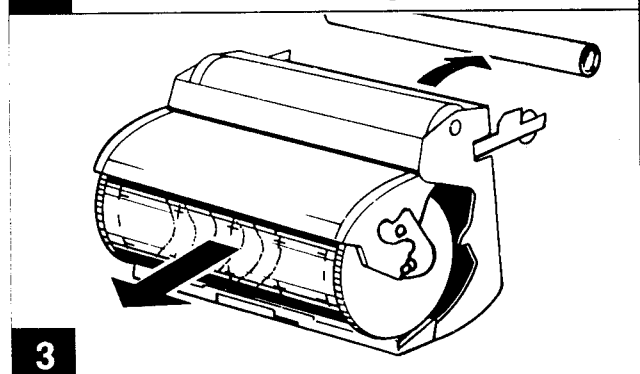
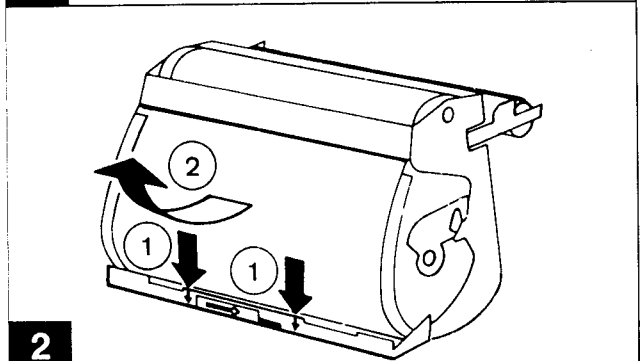
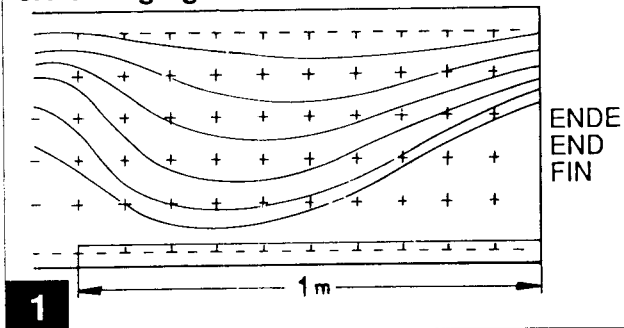

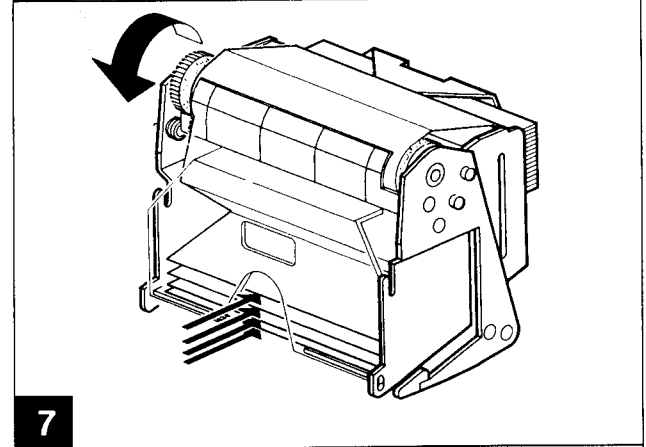
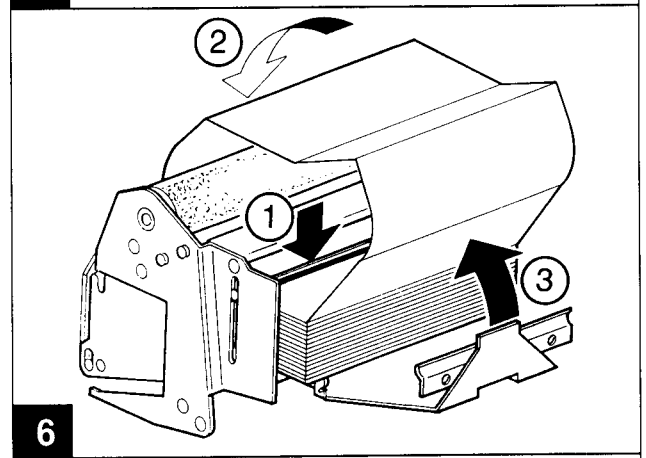
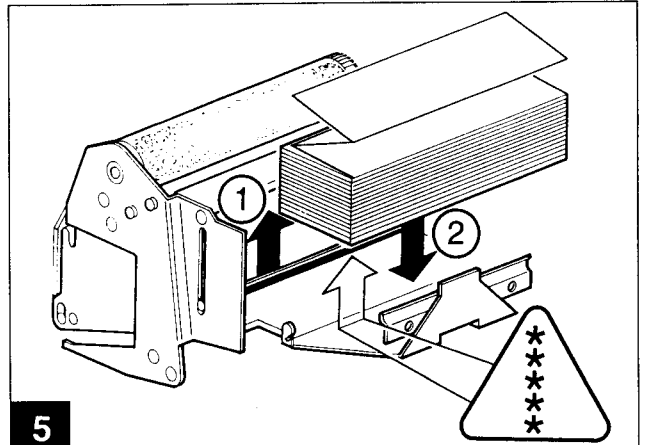
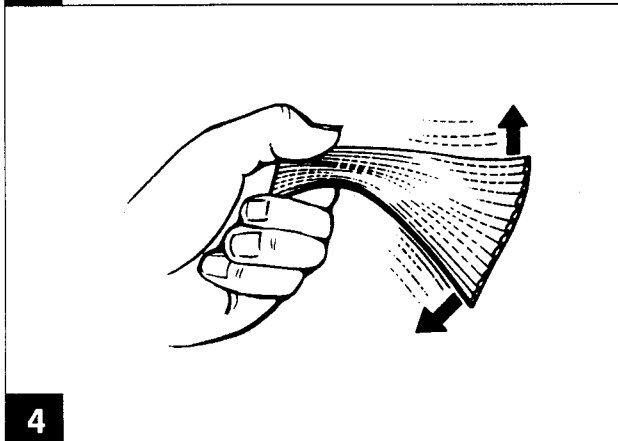
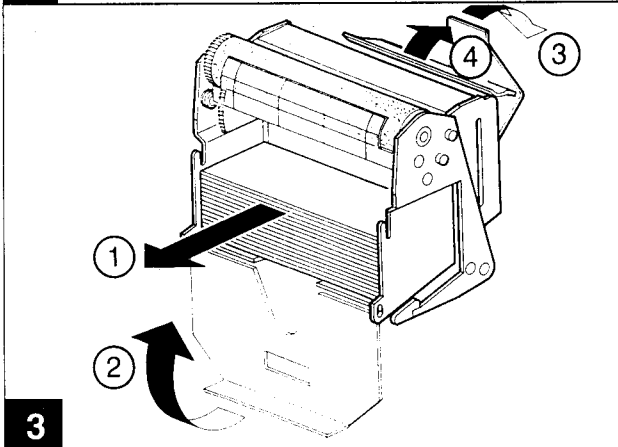
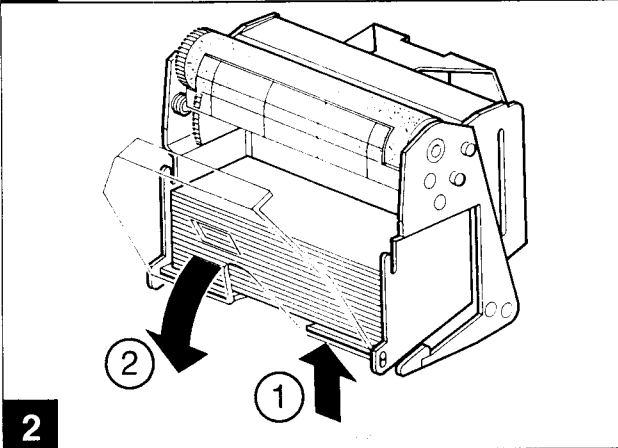
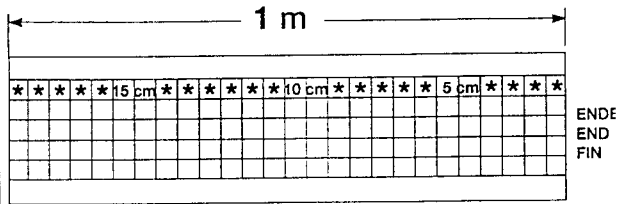

5 CHANGING CONSUMABLES

5.2 Changing the fanfold chart



5 CHANGING CONSUMABLES

5.3 Replacing the print head

Open the housing door. Press key  .
LED acknowledges recording stop. Swing out fascia **1** and wait until the print head **2** stops in the centre position. Pull out the print head. Fit a new print head and swing back the fascia **1**. Press key .

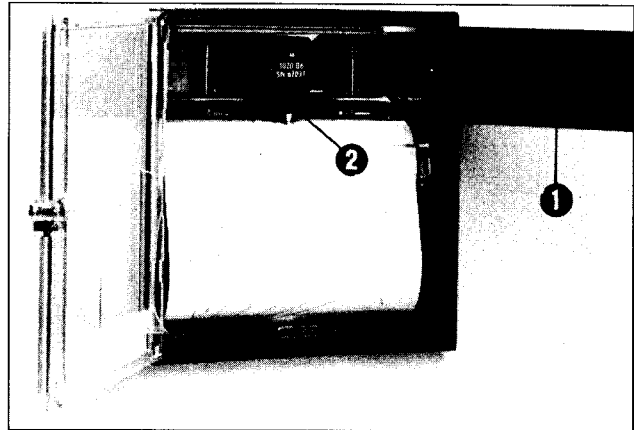

Carry out a print test
(see page 20 "Operating level").

6 FAULT FINDING

6.1 Check mains fuse, replace if required

Switch off the recorder. Take out the chassis. Check the fuse ❶ for continuity, replace if faulty (G fuse M0.63 AE 250 V DIN 41 571/2).

Slide the chassis back into the housing. Energise the recorder again.

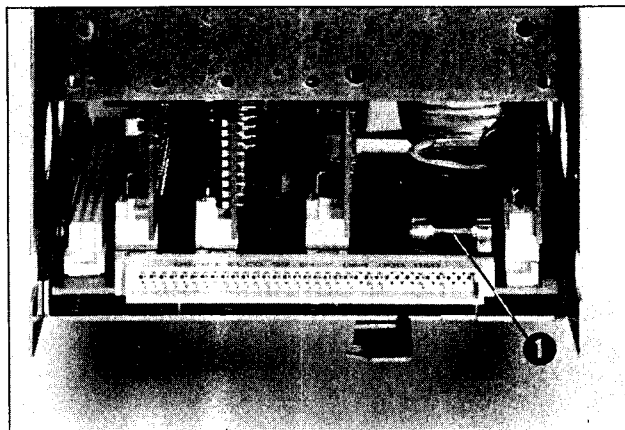

6.2 No recording:

- Has key  been pressed?
- Has chart cassette been fitted correctly?
- End of chart?
- Is "feed" set to zero?
- Is the print head inoperative?
Check position of pen lift.
- External stop?

6.3 Faulty recording:

- Is the print head used up?
Replace print head.

Fault relay drops out when

- ... there is no chart
or at chart end (display: NO PAPER)
- ... RAM battery is exhausted
(display: LOW BATT)
- ... no electrical supply.

Sales Offices and Service Stations – Germany

Berlin

Heinz Konsolke
Zinnaer Strasse 6
14943 Felgentreu
Phone (03 37 34)
2 16 + 2 17 + 3 39
Telefax (03 37 34) 2 35

Darmstadt

M. K. Juchheim GmbH & Co.
Niederlassung Darmstadt
Weiterstädter Strasse 135
64291 Darmstadt-Arheilgen
Phone (0 61 51) 35 08-0
Telefax (0 61 51) 35 08 81
Manager: Wolfgang Vogl

Erfurt

M. K. Juchheim GmbH & Co.
Außenbüro Erfurt
Friedrich-Engels-Straße 12
99334 Ichtshausen
Phone (0 36 28) 7 57 63
Telefax (0 36 28) 7 57 63
Manager: Bernd Westerhoff

Essen

M. K. Juchheim GmbH & Co.
Niederlassung Essen
Alte Bottroper Strasse 45
P. O. Box 11 03 65
45333 Essen
Phone (02 01) 66 30 71-74
Telefax (02 01) 66 87 80
Manager: Lothar Bläser

Giessen

M. K. Juchheim GmbH & Co.
Niederlassung Giessen
An der Amtmannsmühle 1
P. O. Box 11 08
35441 Biebental
Phone (0 64 09) 81 00-0
Telefax (0 64 09) 81 00-49
Manager: Ingo Skrzipczyk

Hamburg

M. K. Juchheim GmbH & Co.
Aussenbüro Hamburg
Horstweg 20
22391 Hamburg
Phone (0 40) 6 01 77 55-56
Telefax (0 40) 6 01 07 34
Manager: Ing. grad. H. Schirner

Hannover

M. K. Juchheim GmbH & Co.
Niederlassung Hannover
Gehrenbreite 2
31542 Bad Nenndorf
Phone (0 57 23) 50 47-49
Telefax (0 57 23) 7 54 11
Manager: Dipl.-Ing. G. Werwitzke

Cologne

M. K. Juchheim GmbH & Co.
Niederlassung Köln
Am Vogelsang 17a
50374 Erftstadt-Liblar
Phone (0 22 35) 9 23 23-0
Telefax (0 22 35) 9 23 23-23
Manager: D. Grosskinsky

Leipzig

M. K. Juchheim GmbH & Co.
Außenbüro Leipzig
Demmeringstrasse 63
04177 Leipzig
Phone (03 41) 4 90 08-10
Telefax (03 41) 4 90 08-32
Manager: Hans-Jürgen Paul

Magdeburg

M. K. Juchheim GmbH & Co.
Außenbüro Magdeburg
Parzellenweg 1a
39130 Magdeburg
Phone (03 91) 7 22 06 19
Telefax (03 91) 7 22 16 19
Manager: Frank Sperling

Munich

M. K. Juchheim GmbH & Co.
Aussenbüro München
Himmelreichweg 23
85221 Dachau
Phone (0 81 31) 8 32 40
Telefax (0 81 31) 8 22 69
Manager: W. Neuwert

Nürnberg

M. K. Juchheim GmbH & Co.
Aussenbüro Nürnberg
Schäferweg 3
91233 Neunkirchen am Sand
Phone (0 91 23) 1 45 46
Telefax (0 91 23) 8 26 73
Manager: Erwin Kolb

Stuttgart

M. K. Juchheim GmbH & Co.
Niederlassung Stuttgart
P. O. Box 12 45
Einsteinstrasse 42
73220 Kirchheim unter Teck
Phone (0 70 21) 8 20 11
Telefax (0 70 21) 5 95 05
Manager: Ing. grad. R. Geier

Europe and USA

Austria

JUMO Mess- u. Regelgeräte Ges.m.b.H.
Pfarrgasse 48, A-1232 Wien
Phone (02 22) 6 10 61-0
Telefax (02 22) 6 10 61-59

Belgium

JUMO AUTOMATION
S.P.R.L./P.G.M.B.H./B.V.B.A.
Industriestrasse 18, B-4700 EUPEN
Phone (0 87) 59 53 00
Telefax (0 87) 74 02 03

Denmark

JUMO Måle- og Reguleringssteknik A/S
Fabriksvænget 16, Postboks 80
DK-4130 Viby Sj
Phone (0) 42 39 30 06
Telefax (0) 42 39 43 63

France

JUMO Régulation S.A., Actipôle Borny
7, rue des drapiers, B. P. 5200
F-57075 Metz-Cedex 3
Phone 87.37.53.00, Telefax 87.74.20.92
Telex 930.464

Italy

JUMO Italia s.r.l.
Piazza Esquilino 5, I-20148 Milano
Phone (02) 40 09 21 41
Telefax (02) 4 07 81 05

Netherlands

JUMO Meet- en Regeltechniek B. V.
Postbus 115, NL-1380 AC Weesp
Phone (0 29 40) 90 76/1 39 91
Telefax (0 29 40) 1 95 77

Representatives in:

Argentina, Baltikum, Brazil, Bulgaria, Canada, Chile, P.R. China, Corea, Croatia, Czech Republic, Finland, Greece, Guatemala, Hungary, India, Indonesia, Iran, Republic of Ireland, Israel, Norway, Poland, Portugal, Romania, Singapore, Slovak Republic, Slovenia, Taiwan, Turkey, Ukraine, Venezuela

Russia

JUMO GmbH
P.O. Box 255, RF-121 019 Moskau
Phone (0 95) 9 30 26 76,
Telefax (0 95) 9 30 26 76,
Telex 411 700 (JUMO S)

Spain

JUMO SERCON S.A.
Taquiraf Garriga, 44
E-08014 Barcelona
Phone (03) 4 10 94 92
Telefax (03) 4 19 64 31

Sweden

JUMO Mät- och Reglerteknik AB
Karbingatan 32, Box 22073
S-250 22 Helsingborg
Phone 0 42-12 36 60
Telefax 0 42-20 16 15, Telex 72 058 jutex S

Switzerland

JUMO Mess- & Regeltechnik AG
Seestr. 67, CH-8712 Stäfa
Phone (01) 9 28 21 41
Telefax (01) 9 26 67 65

United Kingdom

JUMO Instrument Co. Ltd.
Temple Bank, Riverway
Harlow, Essex CM20 2TT
Phone (0 12 79) 63 55 33
Telefax (0 12 79) 63 52 62

USA

JUMO PROCESS CONTROL INC.
735 Fox Chase, Coatesville, PA 19320
Phone 610-380-8002, 800-554-Jumo
Telefax 610-380-8009