

Inductive conductivity transmitter JUMO CTI-920

- inductive conductivity measuring cell
- isolated, hermetically sealed PVDF transducer with integrated Pt100 for temperature measurement /correction of the conductivity measurement
- max. operating temperature 120°C (briefly up to 140°C, e.g. for steam sterilisation)
- max. operating pressure 10 bar
- second current output for temperature provided as standard
- up to 9 measurement ranges integrated
- measurement range 0 – 1 mS/cm to 0 – 2000 mS/cm
- up to 4 temperature coefficients can be set

Typical areas of application:

- food, drinks and pharmaceutical industry
- product monitoring (phase separation product/product mixture/water) in the drinks industry, breweries and dairies
- operation (e.g. phase separation detergent/rinsing water) of cleaning processes
e.g. for bottle cleaning plants and tank cleaning
- concentration control for acids and caustic solutions
e.g. in galvanisation and process chemistry
- use in CIP plants
- water and waste water technology, e.g. for car wash and non-drinking water monitoring
- dosing of chemicals
- leakage indication with separate circuits, e.g. for heating and cooling plants

General application

The inductive conductivity transmitter CTI-920 is used to measure the specific conductivity of liquid media. Its application is particularly recommended for media where severe deposits of dirt, oil, grease, gypsum or lime are to be expected. The inductive measurement process permits a largely maintenance-free acquisition of the specific conductivity, even in the most difficult media conditions. As opposed to the conductive measurement process, problems such as electrode decomposition and polarisation do not occur.

Functional description

Inductive conductivity measurement

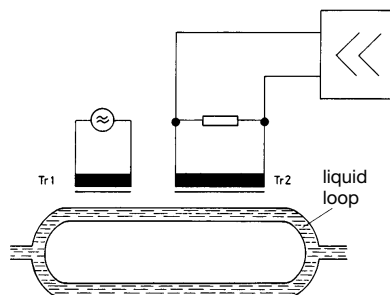

A transformer Tr1 is supplied with a constant alternating voltage and generates a current proportional to the conductivity in the liquid which acts as secondary winding. The liquid also acts as primary winding for a transformer Tr2 which operates as a current transformer. The output current of the transformer Tr2 is directly proportional to the conductivity of the liquid.



Type designation

- Basic type**
- 202752 inductive transmitter head for conductivity and temperature
- /10 version 1, without temperature compensation
 - /21 version 2, with single temperature compensation
 - /22 version 2, with 4-fold temperature compensation
 - /31 version 3, with single temperature compensation
 - /32 version 3, with 4-fold temperature compensation

Pressure connection

- 107 male thread 1¹/₄" pipe A
- 108 male thread 1¹/₂" pipe A
- 110 male thread 2" pipe A
- 160 union nut 2³/₄", PVC, (G+F), e.g. in combination with extra Codes /355, /356 or /357
- 607 screwed pipe joint DN50, DIN 11851
- 608 screwed pipe joint DN65, DIN 11851
- 609 screwed pipe joint DN80, DIN 11851
- 617 clamp connection 2¹/₂"
- 686 connection VARIVENT DN50
- 690 SMS screw joint DN2"

Extra Codes

- /000 without extra Code
- /110 integral digital indicator (3¹/₂ digits)
- /355 PVC tee DN50 (G+F)
- /356 PVC through-flow fitting
- /357 PVC tee DN50 with screwed butt joint

Instrument description

Transmitter

The transmitter CTI-920 has been designed for use on site. A sturdy housing of glass fibre-reinforced polyamide protects the electronics and the electrical connections from corrosive environmental conditions (Protection IP65). A **3-wire transmitter for conductivity** and a **2-wire transmitter for temperature (output signals 4–20mA)** are provided as standard. Optionally, the conductivity can be output via an integrated 3¹/₂ digit LCD digital display. The standard signals can be processed by suitable indicator/ control units or directly on a PLC.

Temperature compensation (TC)

Depending on the instrument version which was ordered, the instrument can be operated without, with single or 4-fold temperature compensation. The strong dependency of the conductivity on the temperature of the medium usually necessitates a compensation of the temperature-dependent variation.

The version **without TC** can be used for measurements with stable temperature conditions in which measurement inaccuracies can be tolerated. In addition, instruments without TC can be connected to evaluation units in which TC is performed in the software, for example (PLC or similar). Note: The standard temperature transmitter is also included in versions without TC.

For most applications the version with a **single TC** is sufficient. A scaled potentiometer enables the adjustment of the temperature coefficient in the range 0 – 3%/°C.

The version with a **4-fold TC** permits a very comfortable process control. Depending on the medium or the medium temperature up to 4 preset temperature coefficients can be selected (selection e.g. via PLC, depending on process development, medium or temperature). The temperature coefficients can also be set via 4 scaled potentiometers in the range 0 – 3%/°C.

Process connections

For a variety of applications, the unit can be supplied with different process connections. If not otherwise specified, the male threads and process connections are made of stainless steel V2A 1.4301 (on request also possible in PP or PVDF).

Measuring cell

The cell consists of a hermetically sealed PVDF body inside which the two measurement coils are arranged. Holes in the measuring cell enable the measurement medium to flow through. The cell is temperature- and pressure-stable to a high degree. For temperature measurement and compensation, the cell is fitted with a fast-response temperature sensor (Pt100). For applications which have to comply with the highest standards of hygiene, connection type VARIVENT is available which also features a cell with a special style (see detailed diagram of process connection -90).

The measurement principle means that there is an inevitable isolation between the measurement medium and the current output.

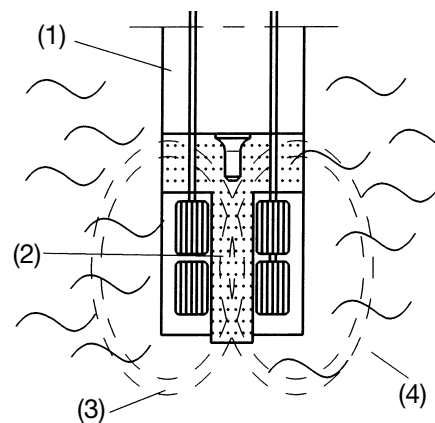

Schematic arrangement of the standard cell

- (1) PVDF body
- (2) T-shaped through-flow channel
- (3) liquid loop
- (4) measurement medium

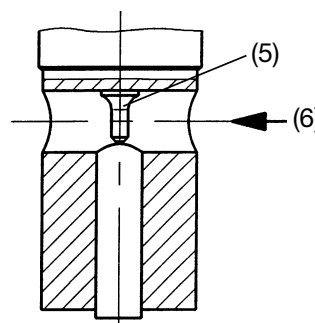

Positioning the Pt100 temperature sensor in the through-flow channel ensures a rapid response of the temperature compensation.

- (5) Pt100 (in stainless steel pocket) in through-flow channel
- (6) through-flow channel

Fitting in position at the location

The CTI-920 can best be fitted in position in a pipe of DN65 or larger by means of a tee with an NW50 screwed pipe joint.

The operating position is generally unrestricted. However, it is essential to ensure that there is a continuous exchange of the measurement medium (6) in the through-flow channel. It may be helpful to mount it from below so that gas bubbles can flow away via the measuring cell without influencing the measurement.

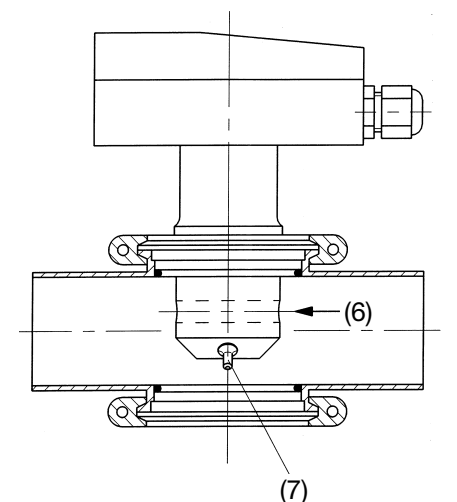
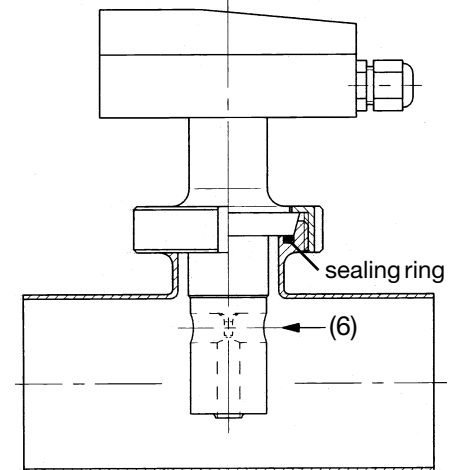

CTI-920 with VARIVENT process connection DN50

built into
Varivent inline housing DN50
(6) through-flow channel
(7) Pt100 in stainless steel pocket

The version VARIVENT features a measuring cell with a straight through-flow channel (6) without internal hindrances. This means an even smaller danger of deposits or blockages. The temperature probe (Pt100 in a stainless steel pocket) protrudes laterally from the measuring cell, which ensures that it is optimally enveloped by the medium.

Ordering example

202752/21-607/110
 Inductive transmitter head
 for conductivity and temperature,
 with single temperature compensation,
 integral digital display (3¹/₂ digits),
 with process connection
 screwed pipe joint DN50, DIN 11851

Standard accessory

Operating Instructions

Available accessories

weld-on threaded pipe adapter DN50
 DIN 11851
 mating connector for
 process connection -85:
 for welding onto tank walls or in pipe lines.

Technical data

Supply

22 – 30 V DC
 nominally 24V DC

Electrical connection

plug-in connectors with screw terminal

Display (option)

3¹/₂ digit LCD digital display for conductivity, automatic adjustment to the selected measurement range
 character height 10 mm

Permitted ambient temperature

-5 to +70°C
 with extra Code /110: 0 – 50°C

Protection

IP65

Housing

glassfibre-reinforced polyamide
 two Pg glands are standard
 (Pg9 and Pg11)

Weight

2 kg approx.

Characteristic data for conductivity transmitter

Version 1:

can be switched over
 0 – 2/20/200 mS/cm,
 0 – 20/200/2000 mS/cm
 or 0 – 5/50/500 mS/cm
without temperature compensation

Version 2:

can be switched over
 0 – 1/10/100 mS/cm,
 0 – 10/100/1000 mS/cm
 or 0-2.5/25/250 mS/cm
with temperature compensation

Version 3:

can be switched over
 0 – 2/20/200 mS/cm
with temperature compensation

Range switching

Three measurement groups can be selected as standard using jumpers (except for version 3). Within these three groups it is possible to switch internally via short-circuit links or externally via floating contacts.

Current output

3-wire circuit
 4 – 20 mA

Current drawn

120 mA max.

Characteristic

linear

Accuracy

2% or better

Max. burden permitted

$$R_{Bmax} = \frac{U_V - 20V}{0.02A}$$

R_{Bmax} = maximum burden permitted
 in Ohm

U_V = supply voltage
 in Volt

Example:

$U_V = 24V$ DC => $R_{Bmax} = 200\Omega$

Characteristic data for temperature transmitter

Temperature measurement range

0 – 150°C

Current output

2-wire circuit
 4 – 20 mA

Current drawn

40 mA max.

Characteristic

linear

Accuracy

2% or better

Max. burden permitted

$$R_{Bmax} = \frac{U_V - 20V}{0.02A}$$

R_{Bmax} = maximum burden permitted
 in Ohm

U_V = supply voltage
 in Volt

Example:

$U_V = 24V$ DC => $R_{Bmax} = 200\Omega$

Temperature compensation (option)

Reference temperature

25°C

Temperature coefficient

1 x 0 – 3%/°C adjustable
 or

4 x 0 – 3%/°C adjustable, can be freely assigned via non-floating voltage

Compensation range

0 – 100°C

Measuring cell

Material

PVDF

Note:

Temperature, pressure and measurement medium influence the life expectancy of the measuring cell

Temperature of the measurement medium

120°C max.

140°C for short periods (sterilisation)

With pressure connection -60 PVC union nut, for extra Code /355 and /356 55°C max.

Pressure

max. 10 bar

Dimensions

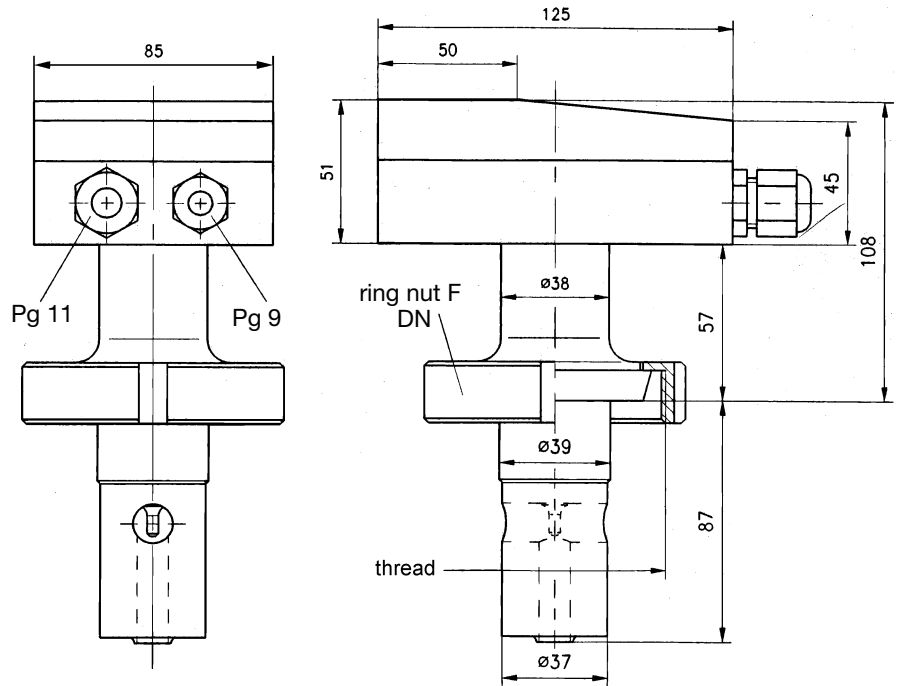

Process connection	
-607	screwed pipe joint DN50
-608	screwed pipe joint DN 65
-609	screwed pipe joint DN 80

Available accessory

for process connection -607

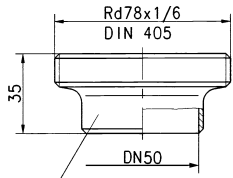

weld-on threaded pipe adapter DN50
DIN 11851

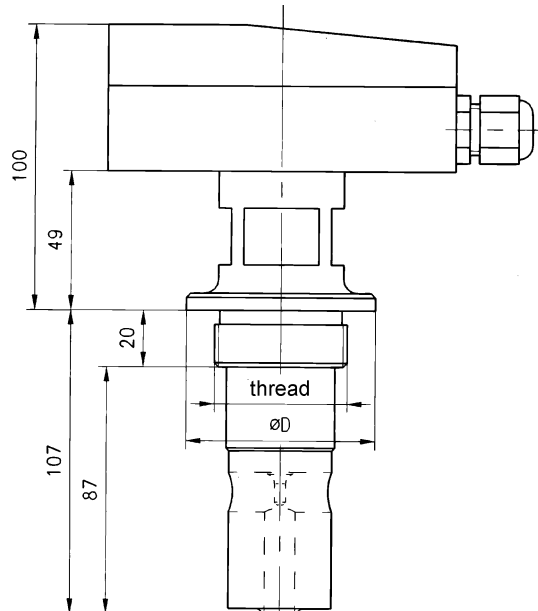

Process connection		dia.
-107	male thread 1 1/4" pipe A	60
-108	male thread 1 1/2" pipe A	68
-110	male thread 2" A	78

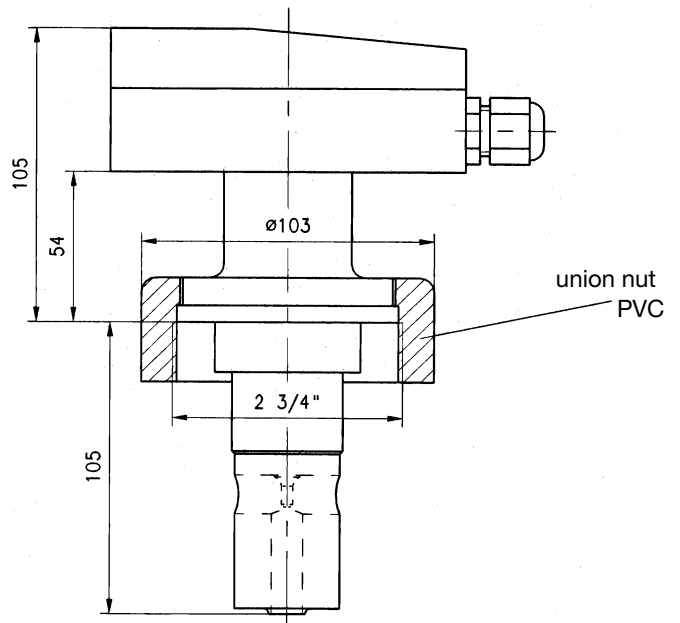

Process connection	
-160	union nut 2 2/3", PVC

Extra Codes

Process connection	
-617	clamp connection 2 1/2"

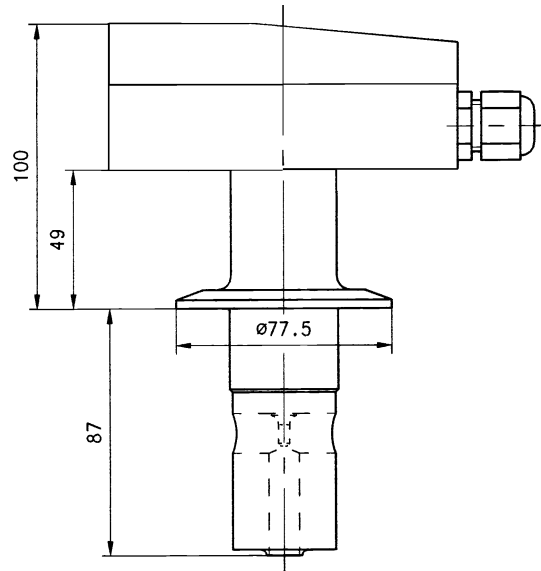

Process connection	
-686	connection VARIVENT

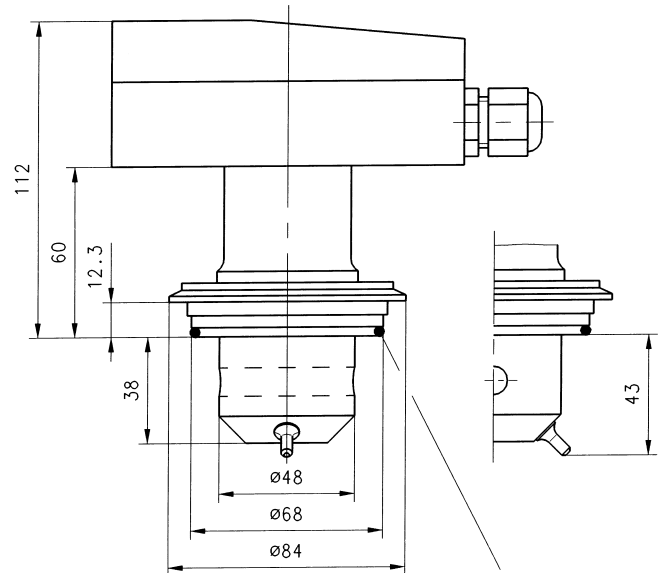

Process connection	
-690	SMS thread DN 2"

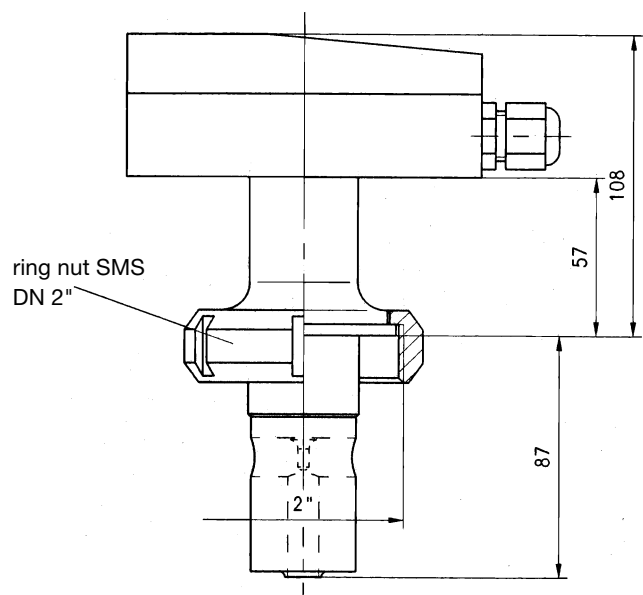

Extra Codes

Extra Code /110 integral digital display (3¹/₂ digits)

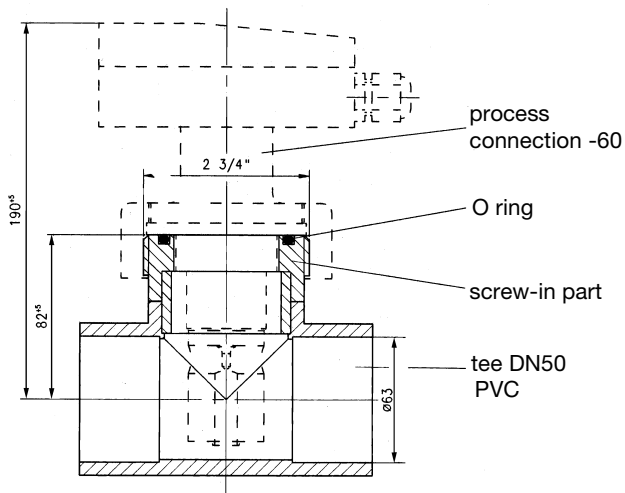
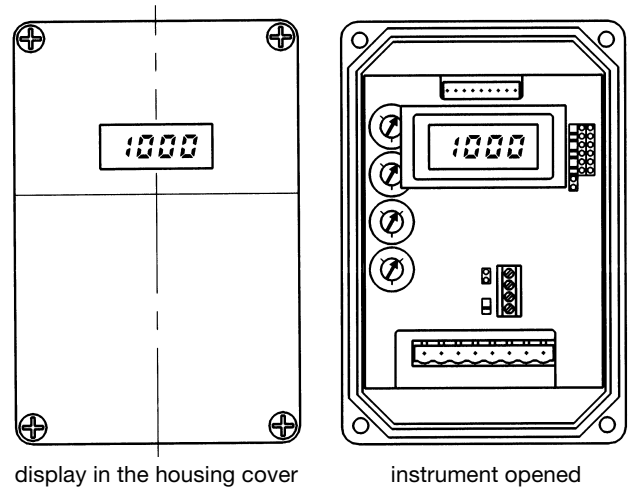

Extra Code /355
PVC tee DN 50

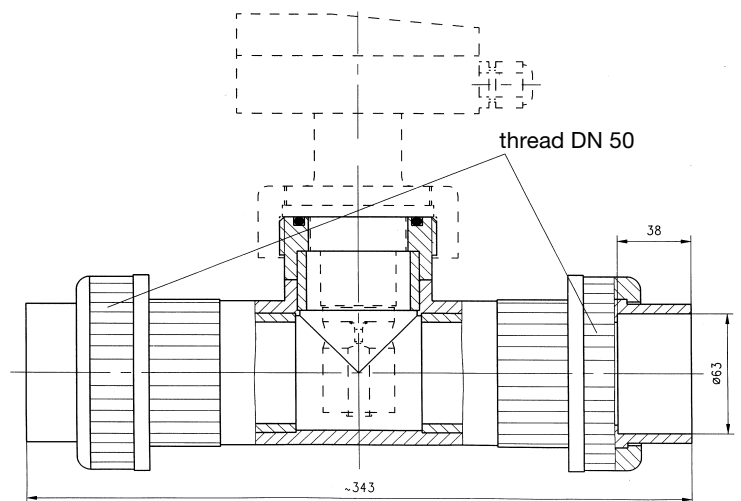

Extra Code / 357
PVC tee with screwed
butt joint DN 50

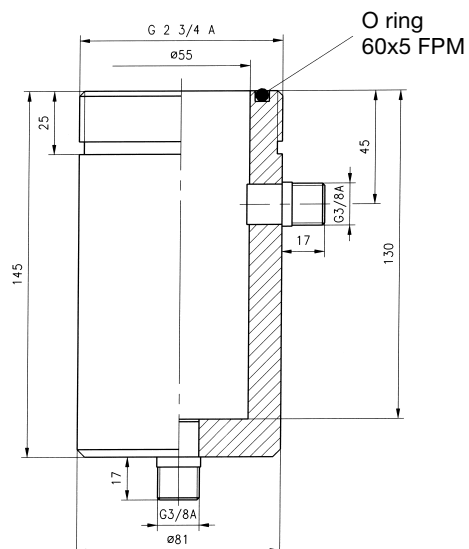

Extra Code /356 through-flow fitting, PVC